

TECHNICAL CATALOGUE

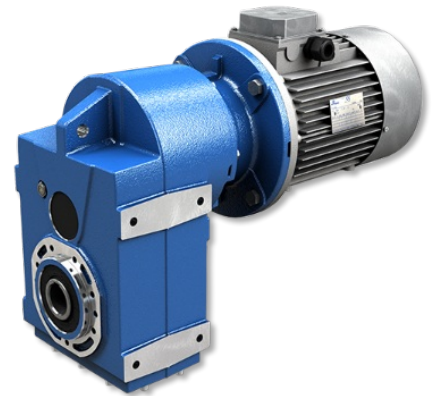

SHAFT MOUNTED GEARED MOTORS

STANDARD **IEC**

1. GENERAL INFORMATION

1.1	COMPANY PROFILE	4
1.2	PRODUCTS AND SOFTWARE MOTOVARIO	6
1.3	SYMBOLS AND FORMULAS	10
1.3.1	Symbols	10
1.3.2	Formulas	11
1.4	PRODUCT SELECTION	12
1.5	SERVICE FACTOR	13
1.6	INSTALLATION	14

2. PRODUCT INFORMATION

2.1	DESIGN FEATURES	15
2.2	TYOLOGY	16
2.2.1	Designation	16
2.2.2	Versions	17
2.2.3	Modularity	18
2.3	MOUNTING POSITIONS	19
2.3.1	Mounting positions	19
2.3.2	Position of terminal box	19
2.4	THERMAL POWER	20
2.4.1	Information	20
2.4.2	Verification	20
2.5	CRITICAL APPLICATIONS	21
2.5.1	Critical applications	21
2.5.2	Information	21
2.6	MOTOR FLANGE AVAILABILITY	22
2.7	OUTPUT SHAFT BEARINGS	26
2.8	OVERHUNG LOAD	27
2.8.1	Information	27
2.8.2	Input	27
2.8.3	Output	28
2.9	LUBRICATION	29
2.9.1	Information	29
2.9.2	Lubricants	29

2.9.3	Special lubricants	30
2.9.4	Quantity	31
2.10	MOMENTS OF INERTIA	32

3. DIMENSIONS

3.1	REDUCERS/GEARED MOTORS	33
3.1.1	S 052...123	33
3.1.2	S 142...153	34
3.1.3	CS 052...123	35
3.1.4	IS 052...123	37
3.1.5	IS 142...153	38
3.2	ELECTRIC MOTORS	39
3.2.1	Electric motors	39
3.2.2	Standard high efficiency (TS), high (TH) and premium (TP) motors	41
3.2.3	Nominal power - [kW]	42
3.3	WEIGHTS	43
3.4	SHAFT END	44

4. ACCESSORIES AND OPTIONS

4.1	LOW SPEED SHAFTS	45
4.2	OUTPUT FLANGE	46
4.3	SHAFT MOUNTING FASTENING	47
4.3.1	Reaction bolt	47
4.3.2	Torque arm - S 142...153	47
4.4	BACKSTOP DEVICE	48
4.5	OUTPUT SHAFT WITH SHRINK DISC	49
4.6	REINFORCED OIL SEALS FOR OUTPUT SHAFT	50
4.7	ASSEMBLING/DISASSEMBLING KIT	51
4.8	MACHINE AXIS	52

5. PERFORMANCES

5.1	S GEARED MOTORS (50Hz)	53
-----	-------------------------------------	----

5.2	IS GEAR REDUCER - 1750 rpm	144
5.3	IS GEAR REDUCER - 1400 rpm	152
5.4	IS GEAR REDUCER - 1140 rpm	160
5.5	IS GEAR REDUCER - 900 rpm	168
5.6	IS GEAR REDUCER - 700 rpm	176
5.7	IS GEAR REDUCER - 500 rpm	184

6. TXF/S - PERFORMANCES

6.1	TXF - PERFORMANCE	192
-----	-------------------------	-----

7. SALES CONDITIONS

7.1	SALES CONDITIONS	195
-----	------------------------	-----

Motovario® corporate philosophy aims to promote the company's brand and products at an international level with determination and transparency, while constantly striving to offer innovative solutions for satisfying and anticipating the demand of the market. Motovario® provides technologically advanced solutions in the transmission components field for industrial and civil applications worldwide.

The company

At Formigine, the heart of Modena's industrial district, Motovario® boasts a production plant spanning 50,000 m² that employs 500 people.

1965 Foundation of Motovario

1998 Acquisition of Spaggiari Trasmissioni, an important brand in the mechanical technology sector.

2006 Motovario acquisition by a private investment fund managed by Synergo SGR, in order to guarantee its development and support its expansion throughout the world.

2014 Acquisition of Pujol.

2015 Acquisition by TECO.

At the core of Motovario® lies an evolved production process based on technological solutions that convert power into movement. Motovario® is at the heart of the production processes that drive industries worldwide. Quality and reliability are the company's fundamental assets. Motovario® is present throughout the world with branches in France, Spain, Germany, England, China, the United States and India. The sales network and customer service guarantee immediate and high-quality support to all customers. In addition, the company boasts a worldwide network of MAC (Motovario Assembly Centre). Qualified assembly centres are present, in Italy, Australia, Benelux, Bulgaria, China, Finland, France, India, Ireland, Israel, Malaysia, Poland, Portugal, South Korea, Spain, Sweden, Turkey, United Kingdom, Ukraine and USA. The company is able to offer a wide range of products: speed variators, right-angle, helical-bevel, shaft-mounted, worm gear reducers and gearmotors, electric motors, inverter and inverter drives. Maximum quality and precision are ensured by the cutting-edge technologies implemented in the production process. 170 numerical control machines, served by LGV lines for storage in automatic warehouses, ensure a high standard of efficiency for the Motovario® production department.

The highly automated assembly lines are supported by a specific computerised system. The process statistical control system manages the production process to avoid rejects, by enabling the operator to monitor all the processing phases. The annealing, tempering, hardening and carburizing treatments are carried out inside the plant. The plant operates on a 24-hour basis, including holidays. Reliability, resilience and versatility are the distinctive features of Motovario® products, the most qualified solution to any power transmission requirement.

Main fields OF APPLICATIONS

- Mechanical-electromechanical industry (car washing, pumps, barriers & automatic doors, circuit breakers)
- Ceramic industry (ovens, press feeding systems)
- Food, farming, oenology industry
- Wood, marble, glass industry
- Packaging & bottling industry
- Textile, shoes, leather industry
- Transport, logistic industry
- Construction industry
- Milling, animal husbandry, flower industry
- Machine tools & steel industry
- Mining, quarry, cement industry
- Energy industry (solar, nuclear, biomass, wind)
- Amusement industry (theatres, leisure parks, kiddy rides)
- Chemical & pharmaceuticals industry
- Paper & printing industry
- Plastic & rubber industry
- Telecommunications industry (satellite orientation systems, military radar)
- Engineering and consultant companies

Certifications

Our products can be manufactured to conform with the ATEX Directive 2014/34/UE. In addition, the safety and quality of our motors, geared motors and motovariators is guaranteed by the EAC (EurAsian Conformity) certification, an essential requirement for products exported to the Russian Federation. Our motors are UL certified, which guarantees their safety and quality requirements for the North American market.

Quality CONCEPT

Motovario® has obtained the quality certification renewal of its production system in conformity to the UNI EN ISO 9001:2008 standard. This internationally recognised certification acknowledges the company's commitment and drive geared towards constantly improving products, projects and services offered. Moreover, the company has obtained the OHSAS 18001:1999 (Occupational Health and Safety Assessment Series) certification, which defines the requirements of the workplace safety and health management system.

Research & DEVELOPMENT

Technological innovation: a crucial factor for competing in the market. In the company's 50-year history, research and change have been the pivotal factors in guaranteeing competitiveness at a global level, thanks to increasingly advanced products in terms of performance and reliability. Each year the company invests an increasing amount of its turnover in research and development, geared towards promoting the constant study and analysis of products, control processes and performance certification. In order to ensure that customers receive products that comply with the requested performance levels, the company carries out simulations on all new products, including NVH (Noise, Vibration, Harshness) tests effected in the advanced semi-anechoic chamber.

Customer CARE

Innovative instruments and software applications supporting the technical and logistic requirements of our partners worldwide guarantee a timely and customised service. The experience acquired by Motovario® has led to the creation of the new online portal MyMotovario 4.0, which allows for selecting products and exporting their 3D file. As a result, designers and engineering departments can download the three-dimensional model of the requested product and implement it directly in their own layout. In order to maximise customer service and quality, Motovario® offers all its customers the following online services: Order Tracking, which allows for monitoring the progress of an order in real time, and the Stock Availability service, through which users may check the availability (stock) of our products, both in the Italian plant and in the various branches.

Motovario chooses technological evolution.

Motovario® has chosen technological evolution and actively collaborates with the Faculty of Engineering of the University of Modena and Reggio Emilia and of the University of Bologna.

Reliability, sturdiness, versatility

These are the distinctive traits of Motovario products. A broad range of transmission products that provide a competent, innovative solution to each and every power application need. Cutting-edge tools, unrelenting research efforts and ongoing commitment to upgrading manufacturing equipment to the latest state-of-the-art enable us to offer high quality and performance standards to cater to industry requirements and the broadest variety of applications. Motovario ranks among the leading, well-reputed companies in Italy engaged in the design, manufacture and sales of transmission products for industrial and civil applications. The entire manufacturing process takes place in Formigine and Ubersetto plants, in Modena area, with an overall surface area of over 50.000 sq m. and a workforce of about 500 people. 170 numerically controlled machines and cutting-edge handling, storage and assembly automated systems ensure that all products meet high quality standards. The network includes more than 40 Motovario-certified assembly centres, with the capability to supply products in a broad range of versions, including customised versions, high service capacity and fast response. As a result, our product offering can cater to the needs of all plant engineering sectors, in all industries and for different applications, and includes: speed variators, helical, bevel-helical, parallel helical, worm gear reducers and gearmotors, electric motors and motor-inverters. All of the products we manufacture share such common features as reliability, sturdiness and versatility, topped with a high innovation content. At the heart of a company's technological innovation is the ability to develop integrated tools for computer-aided calculation simulation and management of different processes as part of product development. When simulating operating, setup and process conditions, it is also necessary to analyse and optimize the overall functional design of a product using a synergistic approach. This is achieved by implementing an exhaustive experimental plan, without using interpolation or approximation, as they frequently allow criticalities or any oversizing which is not conducive to maximising quality/cost ratio to go unnoticed.

High-efficiency method for calculation according to standards

A set of specific functions have been developed to this end. A few significant examples include functions to:

- Optimise individual reduction ratios and the combinations of the different reduction stages based on parametrisable target normal series;
- Calculate torque values and maximum permissible external forces for gear reducer units, using iterative numeric algorithms to confirm target life/safety values of components;
- Create databases for loading a FEM structural analysis model by automatically writing all reaction components of bearings under all load conditions to a specific file, with automatic selection of critical cases that need to be verified.

Another goal of the method is to create synergy between calculation according to standards and FEM structural calculation and the implementation of FEM model loading procedures, so as to simplify input data, meshing and constraint criteria

Competitiveness and operational benefits of the new method

This method offers many practical advantages over traditional calculation procedures within the company, namely:

- Iterative optimisation of project since setup stage;
- Accurate assessment of the various service factors and reliability levels for the entire gear reducer unit and for all operating conditions as per catalogue rating or customer specific requirements;
- Faster support to customers in analysing tailored product configurations;
- Integrated corporate databases that can be updated in real-time;

Range extension and ongoing evolution

The steady, significant growth of Motovario Group is achieved thanks to an ongoing search for new calculation and design tools, as well as to customer service. The new tools identified have led to innovation, improved product reliability as well as positive developments in market management. The following software products are used for design, calculation and management:

- Solidworks;
- Kisoft;
- Kissys;
- Ansys;
- FEM modelling analysis software;
- Circuit design and simulation software;
- Specific spreadsheets;
- SAP.

In MyMotovario 4.0 portal, PRODUCT SELECTION includes a section named APPLICATIONS where customers can enter application data and find out which gear reducer suits them best in a matter of minutes.

MOTOVARIO Products

HELICAL GEAR REDUCERS

Cast iron or aluminum casing
 Output shaft up to 90 mm
 Mn₂ up to 8.600 Nm
 Reduction stages 1, 2, 3
 Ratios up to 354
 Atex units

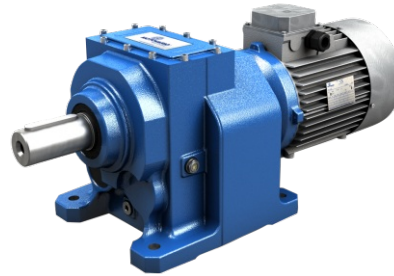
**HELICAL BEVEL GEAR REDUCERS**

Cast iron or aluminum casing
 Output shaft up to 110 mm
 Mn₂ up to 14.000 Nm
 Reduction stages 2, 3
 Ratios up to 443
 Atex units

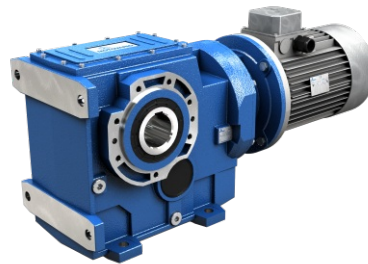
**SHAFT MOUNTED GEAR REDUCERS**

Cast iron
 Output shaft up to 90 mm
 Mn₂ up to 10.250 Nm
 Reduction stages 2, 3
 Ratios up to 395
 Atex units

**WORM GEAR REDUCERS**

Cast iron or aluminum casing
 Output shaft up to 50 mm
 Mn₂ up to 2.700 Nm
 Ratios up to 1083
 Atex units



**PARALLEL HELICAL AND
BEVEL HELICAL GEAR REDUCERS
FOR MIDDLE HEAVY INDUSTRY**

Cast iron casing
Output shaft up to 180 mm
Mn₂ up to 110.000 Nm
Reduction stages 1, 2, 3, 4
Ratios up to 636
Atex units

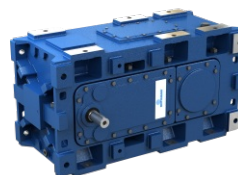
**MOTOVARIATORS AND
MOTOVARIATOR-GEAR REDUCERS**

Cast iron or aluminum casing
Ratios infinite
Mn₂ up to 5.000 Nm
Atex units



<p>ELECTRIC MOTORS</p> <p>Power ratings up to 90 kW Poles 2, 4, 6 Three-phase and single-phase, built-in brake, dual polarity Protection class up to IP66</p>		
	<p>DRIVON - motoinverter</p> <p>Three phase and single phase power supply High dynamics sensorless vectorial control Power ratings up to 5,5 kW Standard integrated STO Integrated field bus Optional field bus</p>	
<p>DRIVES</p>	<p>LM16 - EM16 - AM16 - inverter</p> <p>Compact, standard and premium/servo drive Protection class IP20 - IP66 Torque and speed regulation PLC integrated functions</p>	

1.3.1 Symbols

Physical dimension	Symbol	Symbol units of measure	Input	Output
Power	P	[kW]	P ₁	P ₂
Requested power	Pr	[kW]	Pr ₁	Pr ₂
Nominal power	Pn	[kW]	Pn ₁	Pn ₂
Torque	M	[Nm]	M ₁	M ₂
Nominal torque	Mn	[Nm]		Mn ₂
Requested torque	Mr	[Nm]	Mr ₁	Mr ₂
Speed	n	[rpm]	n ₁	n ₂
Force	F	[N]		
Radial load	Fr	[N]	Fr ₁	Fr ₂
Axial load	Fa	[N]	Fa ₁	Fa ₂
Reduction ratio	i			
Dynamic efficiency	η_d			
Service factor	f.s.			
Static	s			
Dynamic	d			
Calculated	c			
Maximum	max			
Minimum	min			
Moment of inertia	J	[kgm ²]	J ₁	
Ambient temperature	T _{amb}	[°C]		
Dimension		[mm]		

1.3.2 Formulas

REDUCER		
Starting or stopping time	$t = v / a$	[s]
Velocity in rotary motion	$v = \pi * d * n / 60$ $v = \omega * r$	[m/s]
Speed velocity Angular velocity	$n = 60 * v / (\pi * d)$ $\omega = v / r$	[rpm] [rad/s]
Acceleration or deceleration according to a starting / stopping time	$a = v / t$	[m/s ²]
Angular acceleration	$\alpha = n / (9,55 * t)$ $\alpha = \omega / t$	[rad/s ²]
Starting or stopping distance (according to acceleration / deceleration or angular velocity)	$s = a * t^2 / 2$ $s = v * t / 2$	[m]
Horizontal translation force	$F = \mu * m * g$	[N]
Vertical translation force (lifting)	$F = m * g$	
Inclined plane translation force	$F = m * g (\mu * \cos\beta + \sin\beta)$	
m= mass [kg]; g= gravity acceleration [m/s ²]; μ = friction coefficient; β = angle of inclination		
Moment of inertia	$J = m * v^2 / \omega^2$	[kgm ²]
Torque	$M = F * d / 2$ $M = J * \omega / t$	[Nm]

MOTOR and GEARMOTOR		
Starting time	$t_a = (J_{ext} + J_m) * n_n / 9,55 + (M_{peak} - M_r)$	[s]
Braking time	$t_s = (J_{ext} + J_m) * n_n / 9,55 + (M_{peak} + M_r)$	[s]
Motor rotation angle during starting	$\varphi = n_n * t_a / 19,1$	[rad]
Motor rotation angle during braking	$\varphi = n_n * t_s / 19,1$	[rad]
Power available at the shaft of single phase motor	$P = V * I * \eta * \cos\omega$	[W]
Power available at the shaft of three phase motor	$P = 1,73 * V * I * \eta * \cos\omega$	[W]

RUNNING at 60Hz		
Speed velocity at 60Hz	$n_{60Hz} = 1,2 * n_{50Hz}$	[rpm]
Power at 60Hz	$P_{1\ 60Hz} = P_{1\ 50Hz} * V_{60Hz} / V_{50Hz}$	[kW]
If input voltage at 60 Hz (V_{60Hz}) corresponds to winding voltage at 50 Hz (V_{50Hz}), power doesn't change $P_{1\ 60Hz} = P_{1\ 50Hz}$		
If input voltage at 60 Hz (V_{60Hz}) is 20% higher than winding voltage at 50 Hz (V_{50Hz}), power increases by 20% $P_{1\ 60Hz} = 1,2 P_{1\ 50Hz}$		
Torque at 60Hz	$M_{60Hz} = M_{50Hz} * P_{1\ 60Hz} / (1,2 * P_{1\ 50Hz})$	[Nm]
Service factor at 60Hz	$f.s_{60Hz} = f.s_{50Hz} * 1,175 * P_{1\ 50Hz} / P_{1\ 60Hz}$	-

For correctly selecting a gear reducer or geared motor, several essential pieces of data are required:

- A. The rotational input speed to the gear reducer (n_1) and the rotational output speed (n_2). Through these two values it is possible to calculate the reduction ratio (i) of the gear reducer using the following formula: $i = n_1/n_2$
- B. The torque required by the application (Mr_2).

The geared motor or gear reducer can be selected once this data is known.

This guide helps you to select the right product in just a few steps:

Geared motor selection

1. Determine the application's actual service factor (**s.f.**). This parameter depends on the type of load of the powered machine, the number of starts per hour and the hours of operation (refer to the "Service factor" paragraph).
2. Calculate the input power Pr_1 using the required torque value Mr_2 , the speed n_2 and dynamic efficiency value. $Pr_1 = (Mr_2 * n_2) / (9550 * \eta_d)$. The dynamic efficiency value depends on the type of gear reducer and on the number of gear reduction stages. (To calculate the efficiency value see its page).
3. Consult the geared motor performance tables and identify a normalised power value Pn_1 exceeding the required power Pr_1 , such that: $Pn_1 \geq Pr_1$
4. Once the suitable nominal power has been identified, select the geared motor capable of generating the rotational speed closest to the desired n_2 value and with service factor s.f. greater or equal to that required by the application.

In the geared motor selection tables the combinations include 2-pole, 4-pole and 6-pole motors powered at 50Hz.

Gear reducer selection

1. Determine the application's service factor (**s.f.**) (consult to the "Service factor" paragraph on its page) .
2. Calculate the reduction ratio i from the requested output speed n_2 and from the input speed n_1 . $i = n_1/n_2$
3. Calculate the torque M_{c_2} for selecting the gear reducer through the torque required by the application Mr_2 and the service factor s.f.: $M_{c_2} = Mr_2 * (f.s.)$
4. Consult the Gear Reducer Performance tables looking for the reducer that, with the reduction ratio closer to the calculated one, has a nominal torque Mn_2 so that: $Mn_2 \geq M_{c_2}$

Checks

Once the gear reducer or geared motor has been selected, the following checks should be performed:

A. Thermal power

The gear reducer's thermal power must be equal to or greater than the installed mechanical power, or the power required by the application according to the indications contained in the section (refer to the "Thermal power" paragraph).

B. Maximum torque

Generally, the maximum torque (peak instantaneous load) that can be applied to the gear reducer must not exceed 200% of the nominal torque Mn_2 (ATEX - M_{2max}).

C. Radial loads

1. Verify that the radial loads acting on the input and/or output shafts are within with the values indicated in the catalogue. If they exceed these values, increase the size of the gear reducer or modify the external load capacity. During the checking phase, it is important to remember that the values indicated in the catalogue refer to loads acting on the mid-point of the shaft protrusion, therefore, if the load is applied to a different position, appropriate formulas must be used to calculate the admissible load in the desired position (refer to the "Radial loads" paragraph).
2. If accessory output shafts are present, make sure that the applied load is compatible with shaft size. If help is needed: contact MOTOVARIO TECHNICAL SERVICE.

D. If an electric motor is going to be fitted to the selected gear reducer, check for its applicability by referring to the configuration table (see paragraph "Motor flange availability"). From IEC 180 motors, verify if necessary to support the motor with feet. In case of need please contact MOTOVARIO TECHNICAL SERVICE.

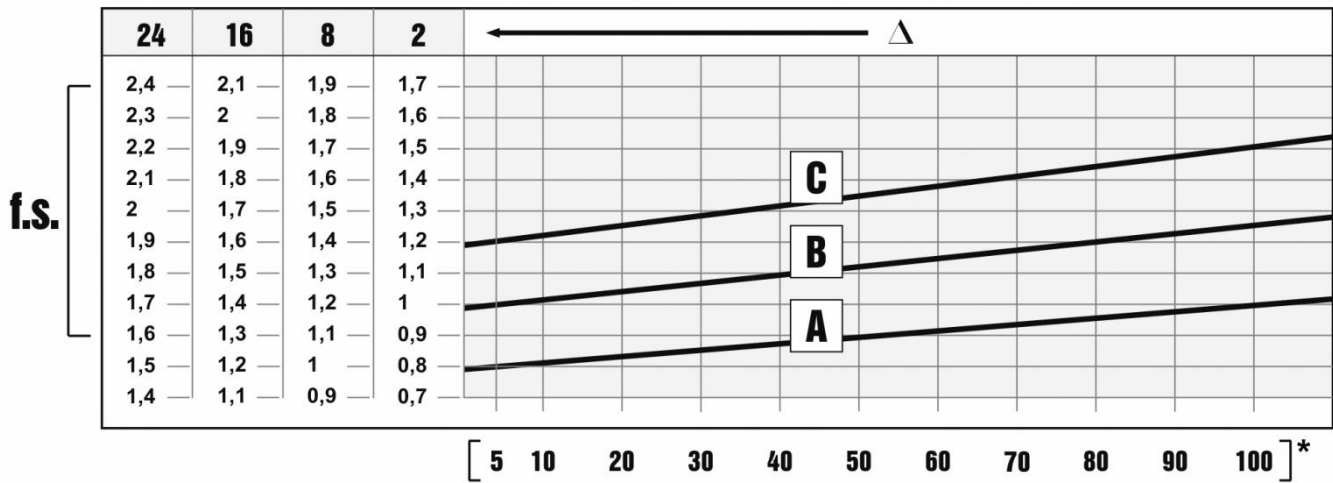

The service factor (f.s.) depends on the operating conditions the gear reducer is subjected to.

The parameters that need to be taken into consideration to select the most adequate service factor correctly comprise:

- type of load of the operated machine : A - B - C
- length of daily operating time: hours/day (Δ)
- start-up frequency: starts/hour (*)

LOAD:

- **A** - uniform = $f_a \leq 0,3$
- **B** - moderate shocks = $f_a \leq 3$
- **C** - heavy shocks = $f_a \leq 10$

$f_a = J_e/J_m$

- J_e [kgm^2] moment of reduced external inertia at the drive-shaft
- J_m [kgm^2] moment of inertia of motor

If $f_a > 10$ call MOTOVARIO TECHNICAL SERVICE.

- Screw feeders for light materials, fans, assembly lines, conveyor belts for light materials, small mixers, lifts, cleaning machines, fillers, control machines.
- Winding devices, woodworking machine feeders, goods lifts, balancers, threading machines, medium mixers, conveyor belts for heavy materials, winches, sliding doors, fertilizer scrapers, packing machines, concrete mixers, crane mechanisms, milling cutters, folding machines, gear pumps.
- Mixers for heavy materials, shears, presses, centrifuges, rotating supports, winches and lifts for heavy materials, grinding lathes, stone mills, bucket elevators, drilling machines, hammer mills, cam presses, folding machines, turntables, tumbling barrels, vibrators, shredders.

To install the gear reducer it is necessary to note the following recommendations:

- Check the correct direction of rotation of the gear reducer output shaft before fitting the unit to the machine.
- In the case of particularly lengthy periods of storage (4/6 months), if the oil seal is not immersed in the lubricant inside the unit, it is recommended to change it since the rubber could stick to the shaft or may even have lost the elasticity it needs to function properly.
- Whenever possible, protect the gear reducer against solar radiation and bad weather.
- Ensure the motor cools correctly by ensuring good passage of air from the fan side.
- In the case of ambient temperatures $< -5^{\circ}\text{C}$ or $> +40^{\circ}\text{C}$ call MOTOVARIO TECHNICAL SERVICE.
- The various parts (pulleys, gear wheels, couplings, shafts, etc.) must be mounted on the shafts using special threaded holes or other systems that anyhow ensure correct operation without risking damage to the bearings or external parts of the units. Lubricate the surfaces in contact to avoid seizure or oxidation.
- Painting must definitely not go over rubber parts and the holes on the breather plugs, if any.
- For units equipped with oil plugs, replace the closed plug used for shipping with the special breather plug.
- Check the correct level of the lubricant through the indicator, if there is one.
- Starting must take place gradually, without immediately applying the maximum load.
- When there are parts, objects or materials under the motor drive that can be damaged by even limited spillage of oil, special protection should be fitted.

Assembling motor on pam flange

When the unit is supplied without motor, it is necessary to follow these recommendation to ensure the correct assembly of the electric motor. Check that the tolerances for the motor shaft and flange correspond to the "standard". Carefully clean the shaft, spigot and surfaces of the flange removing traces of paint and dirt, and confirm the key is fitted correctly. Fit the half coupling/sleeve to the motor shaft (see picture) taking care to ensure the motor shaft and bearings are not damaged by avoiding excessive force and where necessary using assembly equipment. Place the couplings elastic element onto the motor half coupling and position the motor up to the gear unit ensuring the coupling element is aligned with the driven half coupling. Complete the assembly using the fixing bolts. Key-ways with tightened tolerances.

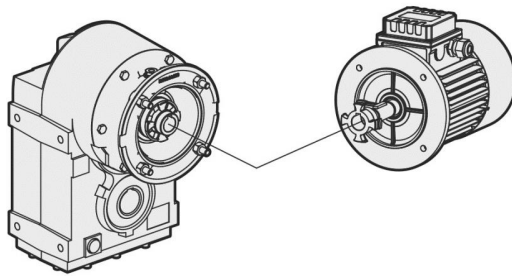
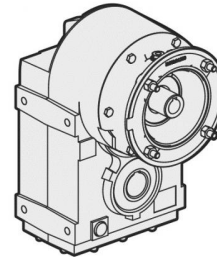
Flexible joint**PAM Sleeve**

Motovario products are supplied with the following surface treatment features:

Grey-coloured cast-iron cases for gears

- Die-cast materials are always painted.

Grey-coloured cast-iron inspection cover: The gear reducer S... series with 2, 3 stages size 125, 140, 150 are supplied with grey-coloured cast-iron closing cover and a metal nameplate printed.



Painting specifications:

- Orange-peel blue epoxy-polyester RAL 5010. Polyester resin based heat-hardening powders, altered with epoxy resins.

Mechanical properties: Tests carried out onto degreased Unichim white lattens (film thickness: 60 microns) comply with the following specifications: adherence (ISO2409).

Heat resistance: 24 HOURS AT 150°C.

Corrosion strength: ASTM B 117/97 salt fog from 100 to 500 hours depending on the support's preliminary treatment.

Performance:

- Loading capacity in accordance with DIN 3990, ISO 6336, AGMA 2101, ISO 10300, DIN 3991, ISO 281, DIN 743.

Efficiency η :

- The efficiency is the ratio between the output power P_2 and the power absorbed by the gear reducer P_1 : $\eta = P_2 / P_1$.

S-range shaft-mounted reducers have an average value equal to:

S..2 stages = 0,96

S..3 stages = 0,94

2.2.1 Designation

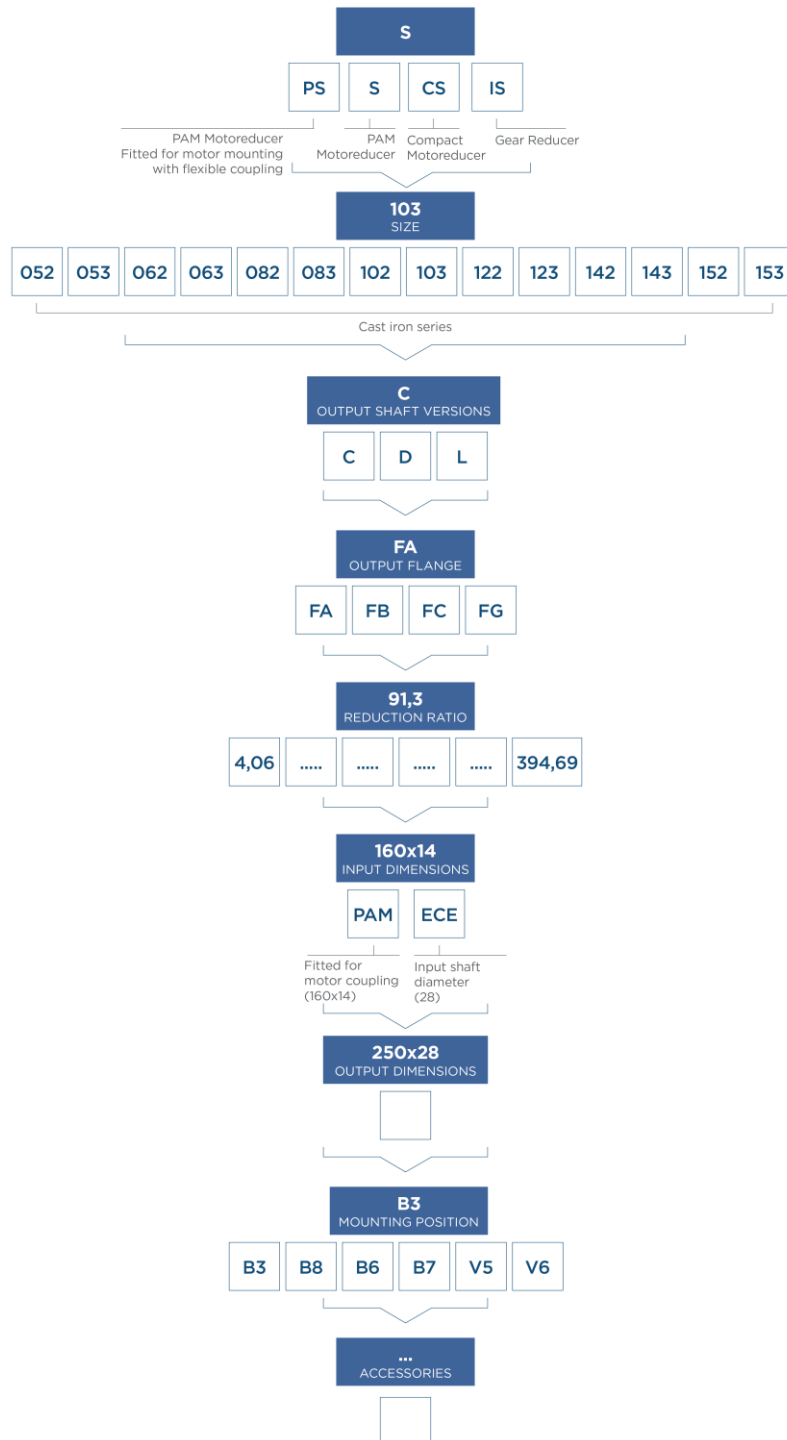

2.2.2 Versions

S... C - S... D - S... L

S.. C FOOT-FLANGE MOUNTING / HOLLOW SHAFT

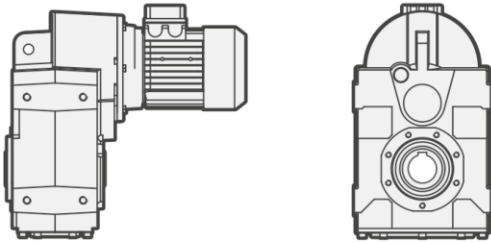

S.. D FOOT-FLANGE MOUNTING / D SOLID SHAFT

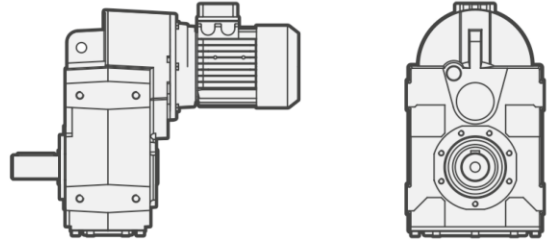

S.. L FOOT-FLANGE MOUNTING / SHRINK DISC SHAFT

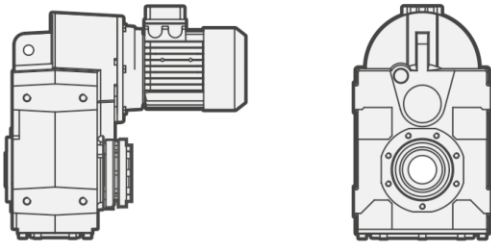

2.2.3 Modularity

S GREY CAST IRON SERIES

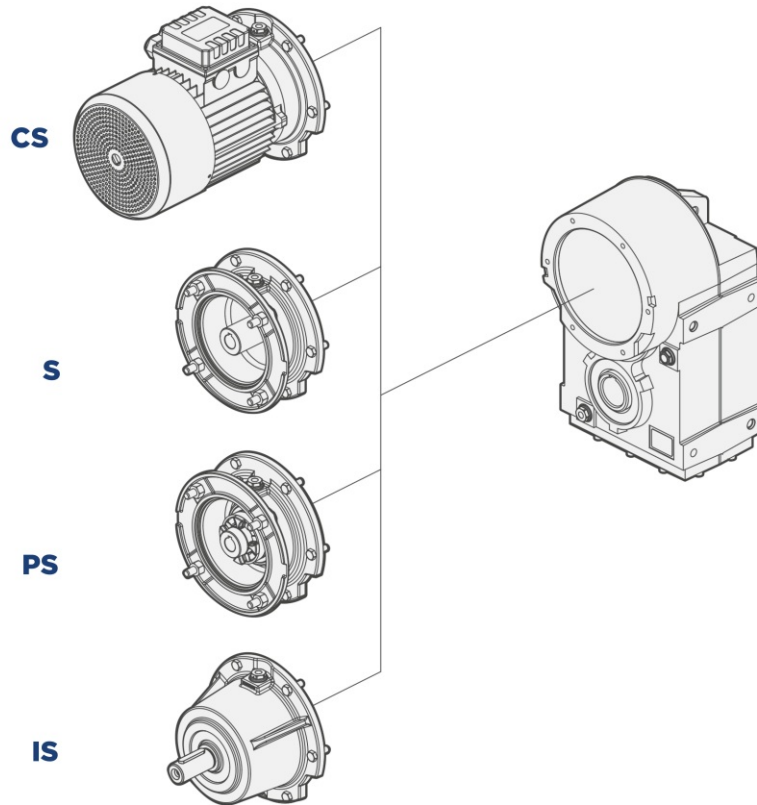

CS
Compact electric motor versions

PS
Fitted for motor mounting
with flexible coupling

S
Fitted for motor coupling version
(PAM)

IS
Input shaft versions

2.3.1 Mounting positions

The mounting position of the gear unit identifies its space orientation. B3 mounting position, as from a technical point of view, ensures lower oil splash, better lubrication and less heating.

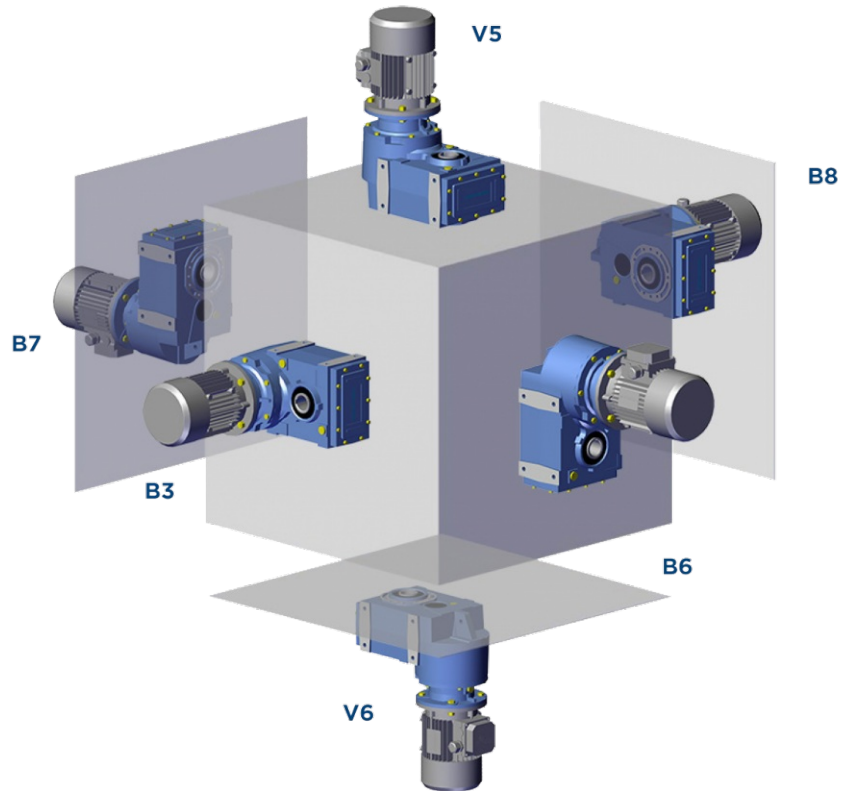

2.3.2 Position of terminal box

Unless otherwise specified when ordering, the gear reducer is supplied with terminal box in position 1.

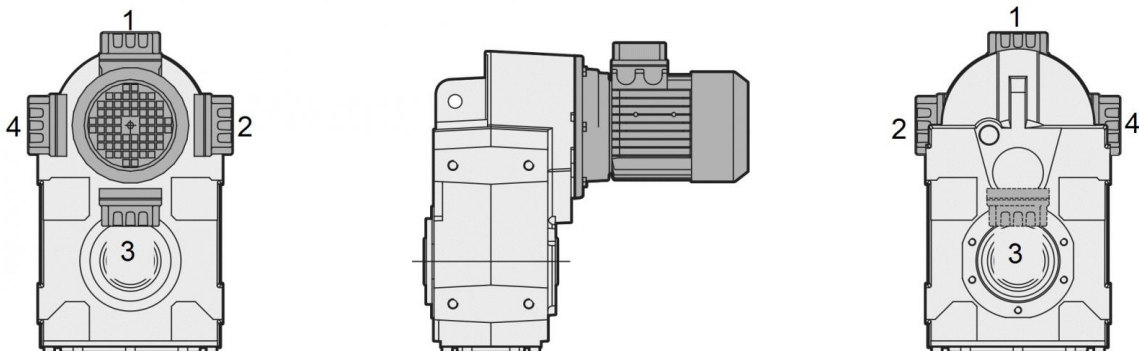

2.4.1 Information

The scheme below indicates the nominal thermal power capacity Pth [kW] according to the following conditions:

- mounting position B3
- continuous operation at input speed ≤ 1500 rpm
- environment temperature $T_{amb}=25^{\circ}\text{C}$
- sea level altitude
- air speed around the gear reducer $\geq 1\text{m/s}$
- absence of external radial and/or axial loads

$n_1=1500\text{rpm}$	
	Pth [kW]
S052	7
S062	9,5
S082	15,5
S102	20,5
S122	34,5
S142	53
S152	65

A correct lubrication and a proper running condition of the gearbox are guaranteed only applying an input power not exceeding Pth (at the above reference conditions)(T oil max=95°C).

NOTE: Normally, three stages gearboxes do not require thermal power verification because the thermal rating usually exceed the mechanical one.

2.4.2 Verification

Application check

Except for continuous operating times below two hours and successive pauses capable of bringing the gear reducer back to ambient temperature, for each application it is peremptory to verify the gear reducer's thermal limit according to the following formula: $P_1 < P_{th} * F_c * F_v * F_a$, where:

- P_1 = input power to the gear reducer [kW]
- P_{th} = thermal power at the reference conditions [kW] (see above table)
- F_c = ambient and operating temperature correction factor
- F_v = ventilation correction factor
- F_a = altitude correction factor

The correction factors refer to different operating conditions compared to the reference conditions, and are provided by the following ISO14179 tables:

Ambient temperature °C	F_c	Duty per hour of operation %				
		100	80	70	40	20
10	1,15	1,21	1,32	1,55	2,07	
18	1,07	1,12	1,23	1,44	1,93	
25	1,00	1,05	1,15	1,35	1,80	
30	0,93	0,98	1,07	1,26	1,67	
40	0,83	0,87	0,95	1,12	1,49	
43	0,75	0,79	0,86	1,01	1,35	
50	0,67	0,70	0,77	0,90	1,21	

Altitude (m)	F_a
0*	1
750	0,95
1500	0,9
2250	0,85
3000	0,81

Ventilation correction factor	F_v
Stagnant air (<0,5 m/s)	0.75
Indoor installation with slight ventilation	1
Indoor installation with good ventilation (>1,4 m/s)	1.4
Installazione all'aperto (>3,7 m/s)	1.9

*Sea level

In case of operation at input speeds exceeding 2000 rpm, or ambient temperatures greater than 40°C, it is advisable to contact our technical department.

2.5.1 Critical applications

S	050	060	080	100	125	140	150
2000 < n1 < 3000	✓	✓	✓	✓	✓	B	B
V6	B	B	B	B	B	B	B
n1 > 3000	B	B	B	B	B	A	A
...L : V5 - V6	B	B	B	B	B	B	B
(*) ...L	B	B	B	B	B	B	B

✓ Verified application

A Application not recommended

B Check the application and/or call MOTOVARIO TECHNICAL SERVICE.

(*) The shrink disc is designed only to transmit the output torque.

In case of mounting position with radial and/or axial loads, please contact MOTOVARIO TECHNICAL SERVICE.

2.5.2 Information

The performance given in the catalogue correspond to mounting position B3 or similar, when the first stage is not entirely immersed in oil. For other mounting positions and/or particular input speeds, refer to the tables that highlight different critical situations for each size of gear reducer. It is also necessary to take due consideration of and carefully assess the following applications by calling MOTOVARIO TECHNICAL SERVICE:

- To avoid the use as multiplier.
- Use in services that could be hazardous for people if the gear reducer fails.
- Applications with especially high inertia.
- Use as a lifting winch.
- Applications with high dynamic strain on the case of the gear reducer.
- In places with T_{amb} under -5°C or over 40°C .
- Use in chemically aggressive environments.
- Use in a salty environment.
- Mounting positions not envisaged in the catalogue.
- Use in radioactive environments.
- Use in environments pressures other than atmospheric pressure.

Avoid applications where even partial immersion of the reducer is required.

In the presence of overloading due to full load, braking, shocks or other static and dynamic causes, please verify that the peak torque is less than $2 \cdot Mn_2$.

2.6 MOTOR FLANGE AVAILABILITY

B11 = Compact electric motor versions.

These tables report all possible dimensions. Please verify service factor.

*For motor size 063 the PS version does not exist.

#Ratio not existent for version IS.

CS - S - PS 052				
i	071	080	090	100-112
8,63	B5-B11	B5-B11	B5-B11	B5-B11
11,14	B5-B11	B5-B11	B5-B11	B5-B11
12,00	B5-B11	B5-B11	B5-B11	B5-B11
13,66	B5-B11	B5-B11	B5-B11	B5-B11
15,27	B5-B11	B5-B11	B5-B11	B5-B11
16,29	B5-B11	B5-B11	B5-B11	B5-B11
18,63	B5-B11	B5-B11	B5-B11	B5-B11
19,73	B5-B11	B5-B11	B5-B11	B5-B11
21,04	B5-B11	B5-B11	B5-B11	B5-B11
21,53	B5-B11	B5-B11	B5-B11	B5-B11
24,07	B5-B11	B5-B11	B5-B11	B5-B11
25,20	B5-B11	B5-B11	B5-B11	B5-B11
25,79	B5-B11	B5-B11	B5-B11	B5-B11
27,81	B5-B11	B5-B11	B5-B11	B5-B11
30,00	B5-B11	B5-B11	B5-B11	
32,55	B5-B11	B5-B11	B5-B11	B5-B11
33,00	B5-B11	B5-B11	B5-B11	
34,09	B5-B11	B5-B11	B5-B11	B5-B11
36,55	B5-B11	B5-B11	B5-B11	
38,75	B5-B11	B5-B11	B5-B11	
39,90	B5-B11	B5-B11	B5-B11	B5-B11
42,63	B5-B11	B5-B11	B5-B11	
46,00	B5-B11	B5-B11	B5-B11	
47,20	B5-B11	B5-B11	B5-B11	
52,25	B5-B11	B5-B11	B5-B11	
57,86	B5-B11	B5-B11	B5-B11	
59,42	B5-B11	B5-B11	B5-B11	
72,83	B5-B11	B5-B11	B5-B11	

CS - S - PS 053				
i	*063	071	080	090
36,50	B5-B11	B5-B11	B5-B11	B5-B11
47,14	B5-B11	B5-B11	B5-B11	B5-B11
57,79	B5-B11	B5-B11	B5-B11	B5-B11
63,74	B5-B11	B5-B11	B5-B11	B5-B11
78,14	B5-B11	B5-B11	B5-B11	B5-B11
74,20	B5-B11	B5-B11	B5-B11	B5-B11
95,84	B5-B11	B5-B11	B5-B11	B5-B11
117,48	B5-B11	B5-B11	B5-B11	B5-B11
137,45	B5-B11	B5-B11	B5-B11	B5-B11
177,55	B5-B11	B5-B11	B5-B11	B5-B11
198,45	B5-B11	B5-B11	B5-B11	
217,64	B5-B11	B5-B11	B5-B11	B5-B11
256,33	B5-B11	B5-B11	B5-B11	
314,21	B5-B11	B5-B11	B5-B11	

2.6 MOTOR FLANGE AVAILABILITY

CS - S - PS 062				
i	071	080	090	100-112
8,00		B5-B11	B5-B11	B5-B11
8,92		B5-B11	B5-B11	B5-B11
9,55		B5-B11	B5-B11	B5-B11
10,65		B5-B11	B5-B11	B5-B11
11,71		B5-B11	B5-B11	B5-B11
13,06		B5-B11	B5-B11	B5-B11
13,36		B5-B11	B5-B11	B5-B11
15,94		B5-B11	B5-B11	B5-B11
16,16		B5-B11	B5-B11	B5-B11
19,29		B5-B11	B5-B11	B5-B11
19,55		B5-B11	B5-B11	B5-B11
23,18	B5-B11	B5-B11	B5-B11	B5-B11
23,75	B5-B11	B5-B11	B5-B11	B5-B11
25,14	B5-B11	B5-B11	B5-B11	B5-B11
27,66	B5-B11	B5-B11	B5-B11	B5-B11
30,00	B5-B11	B5-B11	B5-B11	B5-B11
33,93	B5-B11	B5-B11	B5-B11	B5-B11
36,57	B5-B11	B5-B11	B5-B11	B5-B11
39,38	B5-B11	B5-B11	B5-B11	B5-B11
43,64	B5-B11	B5-B11	B5-B11	B5-B11
46,10	B5-B11	B5-B11	B5-B11	
48,30	B5-B11	B5-B11	B5-B11	B5-B11
53,53	B5-B11	B5-B11	B5-B11	B5-B11
55,00	B5-B11	B5-B11	B5-B11	
67,47	B5-B11	B5-B11	B5-B11	

CS - S - PS 063			
i	071	080	090
33,57	B5-B11	B5-B11	B5-B11
37,77	B5-B11	B5-B11	B5-B11
40,05	B5-B11	B5-B11	B5-B11
49,13	B5-B11	B5-B11	B5-B11
55,29	B5-B11	B5-B11	B5-B11
58,72	B5-B11	B5-B11	B5-B11
65,85	B5-B11	B5-B11	B5-B11
68,25	B5-B11	B5-B11	B5-B11
73,63	B5-B11	B5-B11	B5-B11
81,43	B5-B11	B5-B11	B5-B11
99,89	B5-B11	B5-B11	B5-B11
126,43	B5-B11	B5-B11	B5-B11
150,85	B5-B11	B5-B11	B5-B11
182,53	B5-B11	B5-B11	B5-B11
185,05	B5-B11	B5-B11	B5-B11
217,79	B5-B11		
267,16	B5-B11		

CS - S - PS 082				
i	080	090	100-112	132
7,34	B5-B11	B5-B11	B5-B11	B5-B11
8,06	B5-B11	B5-B11	B5-B11	B5-B11
9,94	B5-B11	B5-B11	B5-B11	B5-B11
11,61	B5-B11	B5-B11	B5-B11	B5-B11
12,75	B5-B11	B5-B11	B5-B11	B5-B11
14,04	B5-B11	B5-B11	B5-B11	B5-B11
15,43	B5-B11	B5-B11	B5-B11	B5-B11
15,73	B5-B11	B5-B11	B5-B11	B5-B11
17,29	B5-B11	B5-B11	B5-B11	B5-B11
19,03	B5-B11	B5-B11	B5-B11	B5-B11
20,14	B5-B11	B5-B11	B5-B11	B5-B11
22,13	B5-B11	B5-B11	B5-B11	B5-B11
24,00	B5-B11	B5-B11	B5-B11	B5-B11
26,05	B5-B11	B5-B11	B5-B11	B5-B11
27,29	B5-B11	B5-B11	B5-B11	B5-B11
28,67	B5-B11	B5-B11	B5-B11	B5-B11
29,60	B5-B11	B5-B11	B5-B11	B5-B11
31,78	B5-B11	B5-B11	B5-B11	B5-B11
34,91	B5-B11	B5-B11	B5-B11	B5-B11
35,50	B5-B11	B5-B11	B5-B11	
40,05	B5-B11	B5-B11	B5-B11	B5-B11
43,05	B5-B11	B5-B11	B5-B11	B5-B11
50,25	B5-B11	B5-B11	B5-B11	
54,27	B5-B11	B5-B11	B5-B11	
61,98	B5-B11	B5-B11	B5-B11	

CS - S - PS 083				
i	071	080	090	100-112
67,52		B5-B11	B5-B11	B5-B11
74,18		B5-B11	B5-B11	B5-B11
81,71		B5-B11	B5-B11	B5-B11
91,49		B5-B11	B5-B11	B5-B11
100,62		B5-B11	B5-B11	B5-B11
117,17	B5-B11	B5-B11	B5-B11	
128,73	B5-B11	B5-B11	B5-B11	
136,34	B5-B11	B5-B11	B5-B11	B5-B11
158,76	B5-B11	B5-B11	B5-B11	
184,88	B5-B11	B5-B11	B5-B11	
203,11	B5-B11	B5-B11	B5-B11	
205,34	B5-B11	B5-B11	B5-B11	B5-B11
226,04	B5-B11	B5-B11	B5-B11	B5-B11
250,50	B5-B11	B5-B11	B5-B11	
266,13	B5-B11	B5-B11	B5-B11	
292,36	B5-B11	B5-B11	B5-B11	
315,73	B5-B11	B5-B11	B5-B11	
360,58	B5-B11	B5-B11	B5-B11	

2.6 MOTOR FLANGE AVAILABILITY

CS - S - PS 102					
i	080	090	100-112	132	160
8,06	B5-B11	B5-B11	B5-B11	B5-B11	B5
8,85	B5-B11	B5-B11	B5-B11	B5-B11	B5
10,88	B5-B11	B5-B11	B5-B11	B5-B11	B5
12,75	B5-B11	B5-B11	B5-B11	B5-B11	B5
13,99	B5-B11	B5-B11	B5-B11	B5-B11	B5
15,43	B5-B11	B5-B11	B5-B11	B5-B11	
17,21	B5-B11	B5-B11	B5-B11	B5-B11	B5
19,00	B5-B11	B5-B11	B5-B11	B5-B11	
20,83	B5-B11	B5-B11	B5-B11	B5-B11	
22,13	B5-B11	B5-B11	B5-B11	B5-B11	
24,28	B5-B11	B5-B11	B5-B11	B5-B11	
26,33	B5-B11	B5-B11	B5-B11	B5-B11	
29,87	B5-B11	B5-B11	B5-B11	B5-B11	
32,40	B5-B11	B5-B11	B5-B11	B5-B11	
34,91	B5-B11	B5-B11	B5-B11	B5-B11	
38,30	B5-B11	B5-B11	B5-B11	B5-B11	
42,53	B5-B11	B5-B11	B5-B11	B5-B11	
44,00	B5-B11	B5-B11	B5-B11		
47,13	B5-B11	B5-B11	B5-B11	B5-B11	
50,25	B5-B11	B5-B11	B5-B11		
55,14	B5-B11	B5-B11	B5-B11		
59,40	B5-B11	B5-B11	B5-B11		
67,84	B5-B11	B5-B11	B5-B11		

CS - S - PS 103				
i	071	080	090	100-112
74,18		B5-B11	B5-B11	B5-B11
81,39		B5-B11	B5-B11	B5-B11
89,77		B5-B11	B5-B11	B5-B11
100,15		B5-B11	B5-B11	B5-B11
110,55	B5-B11	B5-B11	B5-B11	B5-B11
121,29	B5-B11	B5-B11	B5-B11	B5-B11
128,73	B5-B11	B5-B11	B5-B11	B5-B11
141,24	B5-B11	B5-B11	B5-B11	B5-B11
173,78	B5-B11	B5-B11	B5-B11	B5-B11
188,51	B5-B11	B5-B11	B5-B11	B5-B11
203,11	B5-B11	B5-B11	B5-B11	B5-B11
222,85	B5-B11	B5-B11	B5-B11	B5-B11
224,76	B5-B11	B5-B11	B5-B11	B5-B11
274,20	B5-B11	B5-B11	B5-B11	B5-B11
280,89	B5-B11	B5-B11	B5-B11	
292,36	B5-B11	B5-B11	B5-B11	
320,79	B5-B11	B5-B11	B5-B11	
345,60	B5-B11	B5-B11	B5-B11	
394,69	B5-B11	B5-B11	B5-B11	

CS - S - PS 122							
i	080	090	100-112	132	160	180	200
8,48					B5	B5	B5
9,30					B5	B5	B5
10,24					B5	B5	B5
11,42					B5	B5	B5
12,63					B5	B5	B5
13,84					B5	B5	B5
16,99					B5	B5	B5
21,25			B5-B11	B5-B11	B5	B5	
22,37			B5-B11	B5-B11	B5	B5	
23,29			B5-B11	B5-B11	B5	B5	
26,15			B5-B11	B5-B11	B5	B5	
28,60			B5-B11	B5-B11	B5	B5	
30,51			B5-B11	B5-B11	B5	B5	
32,76			B5-B11	B5-B11	B5	B5	
33,44			B5-B11	B5-B11	B5	B5	
35,20			B5-B11	B5-B11	B5	B5	
41,07			B5-B11	B5-B11	B5	B5	
43,60	B5-B11	B5-B11	B5-B11	B5-B11			
44,63	B5-B11	B5-B11	B5-B11	B5-B11			
49,04	B5-B11	B5-B11	B5-B11	B5-B11			
53,75	B5-B11	B5-B11	B5-B11	B5-B11			
66,00	B5-B11	B5-B11	B5-B11	B5-B11			

CS - S - PS 123				
i	080	090	100-112	132
64,84			B5-B11	B5-B11
71,07			B5-B11	B5-B11
78,46			B5-B11	B5-B11
87,27			B5-B11	B5-B11
105,91			B5-B11	B5-B11
112,52	B5-B11	B5-B11	B5-B11	B5-B11
123,33	B5-B11	B5-B11	B5-B11	B5-B11
130,04	B5-B11	B5-B11	B5-B11	B5-B11
133,78	B5-B11	B5-B11	B5-B11	B5-B11
151,43	B5-B11	B5-B11	B5-B11	B5-B11
177,53	B5-B11	B5-B11	B5-B11	B5-B11
194,59	B5-B11	B5-B11	B5-B11	B5-B11
215,60	B5-B11	B5-B11	B5-B11	B5-B11
238,93	B5-B11	B5-B11	B5-B11	B5-B11
# 255,54	B5-B11	B5-B11	B5-B11	
# 280,10	B5-B11	B5-B11	B5-B11	
# 301,16	B5-B11	B5-B11	B5-B11	
# 343,93	B5-B11	B5-B11	B5-B11	

2.6 MOTOR FLANGE AVAILABILITY

S142				
i	132	160	180	200
4.11	B5	B5	B5	B5
4.58	B5	B5	B5	B5
5.14	B5	B5	B5	B5
5.81	B5	B5	B5	B5
6.21	B5	B5	B5	B5
7.31	B5	B5	B5	B5
8.20	B5	B5	B5	B5
9.28	B5	B5	B5	B5
9.91	B5	B5	B5	B5
11.40	B5	B5	B5	B5
12.81	B5	B5	B5	B5
14.27	B5	B5	B5	B5
16.00	B5	B5	B5	B5
18.10	B5	B5	B5	B5
19.33	B5	B5	B5	B5
22.24	B5	B5	B5	B5
25.26	B5	B5	B5	
28.33	B5	B5	B5	
32.05	B5	B5	B5	
34.22	B5	B5	B5	
39.37	B5	B5		

S143			
i	100 - 112	132	160
45.76	B5	B5	B5
50.97	B5	B5	B5
57.17	B5	B5	B5
64.67	B5	B5	B5
69.05	B5	B5	B5
79.45	B5	B5	B5
98.80	B5	B5	
110.05	B5	B5	
123.43	B5	B5	
139.64	B5	B5	
149.09	B5	B5	
157.48	B5		
171.54	B5	B5	
175.40	B5		
196.73	B5		
222.56	B5		
237.62	B5		
273.41	B5		

S152				
i	160	180	200	225
4.06	B5	B5	B5	B5
4.53	B5	B5	B5	B5
5.20	B5	B5	B5	B5
5.71	B5	B5	B5	B5
6.52	B5	B5	B5	B5
7.28	B5	B5	B5	B5
8.35	B5	B5	B5	B5
9.17	B5	B5	B5	B5
10.41	B5	B5	B5	B5
12.46	B5	B5	B5	B5
13.90	B5	B5	B5	B5
15.96	B5	B5	B5	B5
17.52	B5	B5	B5	B5
19.90	B5	B5	B5	B5
22.88	B5	B5	B5	B5
27.10	B5	B5	B5	B5
29.75	B5	B5	B5	B5
33.79	B5	B5	B5	B5
38.84	B5	B5	B5	B5

S153			
i	132	160	180
40.10	B5	B5	B5
44.75	B5	B5	B5
51.37	B5	B5	B5
56.39	B5	B5	B5
64.05	B5	B5	B5
73.62	B5	B5	B5
87.16	B5	B5	
97.27	B5	B5	
111.66	B5	B5	
122.56	B5	B5	
139.20	B5	B5	
154.01	B5		
160.01	B5		
176.81	B5		
194.05	B5		
220.41	B5		
253.35	B5		

2.7 OUTPUT SHAFT BEARINGS

S	S050		S060		S080		S100	
Versions	Standard	On request	Standard	On request	Standard	On request	Standard	On request
C	1	/	1	2	1 (Ø40)	2 (Ø40)	1	2
D	1	/	1	/	2	/	2	/
L	1	/	1	/	1	/	1	/

S	S125		S140		S150	
Versions	Standard	On request	Standard	On request	Standard	On request
C	1	2	1	2	1	2
D	2	/	2	/	2	/
L	1	/	1	/	1	/

1 - Ball Bearing

2 - Roller bearings

/ - Not available

2.8.1 Information

The value of the admissible radial load [N] is given in the tables relating to the performance of the gear reducer at issue. It is related to the load applied on the centre line of the shaft and in the most unfavourable conditions of angle of application and direction of rotation. The maximum admissible axial loads are 1/5 of the value of the given radial load when they are applied in combination with the radial load. The tables relating to the output shafts give the maximum admissible value. This value must never be exceeded since it relates to the strength of the case. Particular conditions of radial load higher than the limits of the catalogue may occur. In this case, call our Technical Service and provide details on the application: direction of the load, direction of rotation of the shaft, type of service. In case of double extension shafts with radial load applied on both ends, the max. admissible radial loads must be defined according to the specific running conditions, in this case call our Technical Service. The radial load on the shaft is calculated with the following formula:

$$Fr_e = (2000 \cdot M \cdot fz) / D \leq Fr_1 \text{ or } Fr_2$$

- **Fr_e** [N] Resulting radial load
- **M** [Nm] Torque on the shaft
- **D** [mm] Diameter of the transmission member mounted on the shaft
- **Fr₁-Fr₂** [N] Value of the maximum admitted radial load (see relative tables)
- **fz** = 1,1 gear pinion - 1,4 chain wheel - 1,7 v-pulley - 2,5 flat pulley

2.8.2 Input

When the radial load is not on the centre line of the shaft, it is necessary to adjust the admissible radial load Fr₁ with the following formula: $Fr_x = (Fr_1 \cdot a) / (b + x)$

- **a**, **b** = values given in the tables
- **x** = distance from the point of application of the load to the shaft shoulder

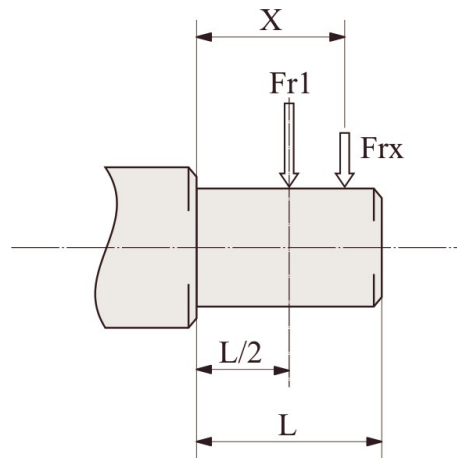

IS	052/053	062/063	082/083	102/103	122/123	142/143	152/153
a	105	105	137	137	175	146	190
b	80	80	108	108	135	106	135
Fr₁ max(**)	1500	2500	3600	3600	7200	4200	5200

(**Fr₁ max) Max admissible value of the reducer in static conditions and/or for limited operations. For continuous overhung loads please check the values on the performances tables calculated according to the casing, the shaft and bearings.

2.8.3 Output

When the radial load is not on the centre line of the shaft, it is necessary to adjust the admissible radial load Fr_2 with the following formula: $Fr_x = (Fr_2 \cdot a) / (b + x)$

- a , b = values given in the tables
- x = distance from the point of application of the load to the shaft shoulder

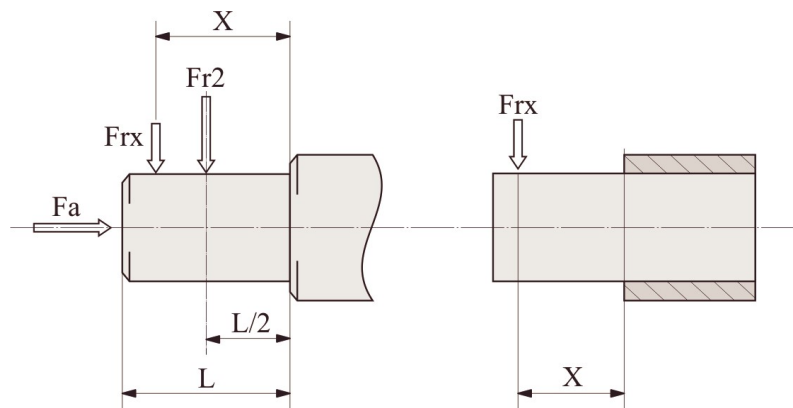

S	052/053	062/063	082/083	102/103	122/123	142/143	152/153
a	125	145	190	225	265	360,5	409,5
b	96	116	150	175	202	261	299
D (Fr_2 max ^{**})	6000	10000	18000	22000	30000	35000	40000
C (Fr_2 max ^{**})	6000	4000	7200	9000	11200	18500	19400

(** Fr_2 max) Max admissible value of the reducer in static conditions and/or for limited operations. For continuous overhung loads please check the values on the performances tables calculated according to the casing, the shaft and bearings.

2.9.1 Information

In cases of ambient temperatures not envisaged in the table, call our Technical Service. In the case of temperatures under -30°C or over 60°C it is necessary to use oil seals with special properties. For operating ranges with temperatures under 0°C it is necessary to consider the following:

1. The motors need to be suitable for operation at the envisaged ambient temperature.
2. The power of the electric motor needs to be adequate for exceeding the higher starting torques required.
3. In case of cast-iron gear reducers, pay attention to impact loads since cast iron may have problems of fragility at temperatures under -15°C .
4. During the early stages of service, problems of lubrication may arise due to the high level of viscosity taken on by the oil and so it is wise to have a few minutes of rotation under no load.

Oil (NON Atex products) must be changed after approx. 10000 hours/2 years of operation; this time varies based on the type of service and on the environment inside which the gear reducer is installed. Units not featuring any oil plug are life-lubricated, and therefore maintenance-free.

2.9.2 Lubricants

Specifications of lubricants recommended by Motovario.

The units **S052/3 ÷ 102/3** are supplied with ENI BLASIA 220 oil, unless otherwise specified by the client.

The units **S122/3 ÷ 152/3** are supplied without lubricant.

	S052/3 ÷ 152/3	
	Mineral oil	
$T_{\text{amb}}^{\circ}\text{C}$ ISO	(-5) ÷ (+40) ISO VG220	(-15) ÷ (+25) ISO VG150
ENI	BLASIA 220	BLASIA 150
SHELL	OMALA S2 G 220	OMALA S2 G 150
KLUBER	Kluberoil GEM 1-220N	Kluberoil GEM 1-150N
MOBIL	MOBILGEAR 600 XP220	MOBILGEAR 600 XP150
CASTROL	ALPHA SP 220	ALPHA SP 150
BP	ENERGOL GR-XP220	ENERGOL GR-XP150

2.9.3 Special lubricants

	$T_{amb}^{\circ C}$	Polyglycol synthetic oil
ENI	(-30) ÷ (+30)	Blasia S 150 (ISO VG150)
	(-20) ÷ (+40)	Blasia S 220 (ISO VG220)
MOBIL	(-45) ÷ (+0)	SCH 624 (ISO VG32)
	(-40) ÷ (+5)	SCH 626 (ISO VG68)
KLUBER	(-40) ÷ (+5)	Klubersynth GH 6-32 (ISO VG32)
	(-35) ÷ 10)	Klubersynth GH 6-80 (ISO VG80)
	(-30) ÷ (+40)	Klubersynth GH 6-150 (ISO VG150)
	(-25) ÷ (+40)	Klubersynth GH 6-220 (ISO VG220)
	(-15) ÷ (+50)	Klubersynth GH 6-460 (ISO VG460)
	(-10) ÷ (+70)	Klubersynth GH 6-680 (ISO VG680)
	$T_{amb}^{\circ C}$	Polyglycol synthetic oil for food grade
KLUBER	(-30) ÷ (+15)	Klubersynth UH1-6 100 (ISO VG100)
	(-25) ÷ (+40)	Klubersynth UH1-6 220 (ISO VG220)
	(-15) ÷ (+40)	Klubersynth UH1-6 320 (ISO VG320)
	(-15) ÷ (+50)	Klubersynth UH1-6 460 (ISO VG460)
	(-10) ÷ (+50)	Klubersynth UH1-6 680 (ISO VG680)

If 'special' lubricant is required please contact for Technical Assistance.

2.9.4 Quantity

- For the gear reducers S ... series with 2, 3 stages it is always necessary to specify the envisaged position.
- The gear S... series with 2, 3 stages sizes 050, 060 gear reducers are supplied complete with lubricant, have no oil plugs and need no maintenance.
- The gear S... series with 2, 3 stages sizes 080, 100 gear reducers are supplied complete with lubricant and are fitted with oil plugs to suit any mounting position included in the catalogue
- The gear S... series with 2, 3 stages sizes 125, 140, 150 have no lubricant and are fitted with oil plugs to suit any mounting position included in the catalogue. The oil filling can be done on request, in this case it is recommended, after installation, to replace the closed plug used for transportation with the supplied breather plug. When the reduction unit is supplied without lubricant, it is provided with a label to be filled.

Oil quantity in the table (litres -) are indicative; for a proper use you will have to refer to the level plug or the dipstick. Any level difference could depend on construction tolerances, but also by the placement of the unit or by the mounting surface at the customer's premises. It is appropriate to check and, if necessary, restores the level when the units are installed.

S - CS	052/053	062/063	082/083	102/103	122/123	142	143	152	153
B3	2,05	2,4	6	9	14,7	22	20	29,7	27
B8	1,8	2,3	4	6	11,8	20	20	31	31
B6	2,4	2,9	5,7	8	16	22 (25)	18 (24,5)	29,3 (42)	24 (40)
B7	2,1	2,6	4,5	6,8	11,3	17,5	14	22,5	18
V5	2,8	3,5	6,8	10,3	19	24,5	23,5	34,4	33
V6	2,4	2,9	6,4	9,9	18	20,8	20	33,3	32

(...) 142-143-152-153 quantity of oil [l] for gearbox with backstop device

The following values of J1 moment of inertia are only estimated, referred to the maximum calculated, and to the gearbox input side.

S-2/3	J ₁ [Kg*m ²]
052/053	0,0004
062/063	0,0006
082/083	0,0015
102/103	0,0034
122/123	0,0085
142/143	0,0384
152/153	0,0830

3.1.1 S 052...123

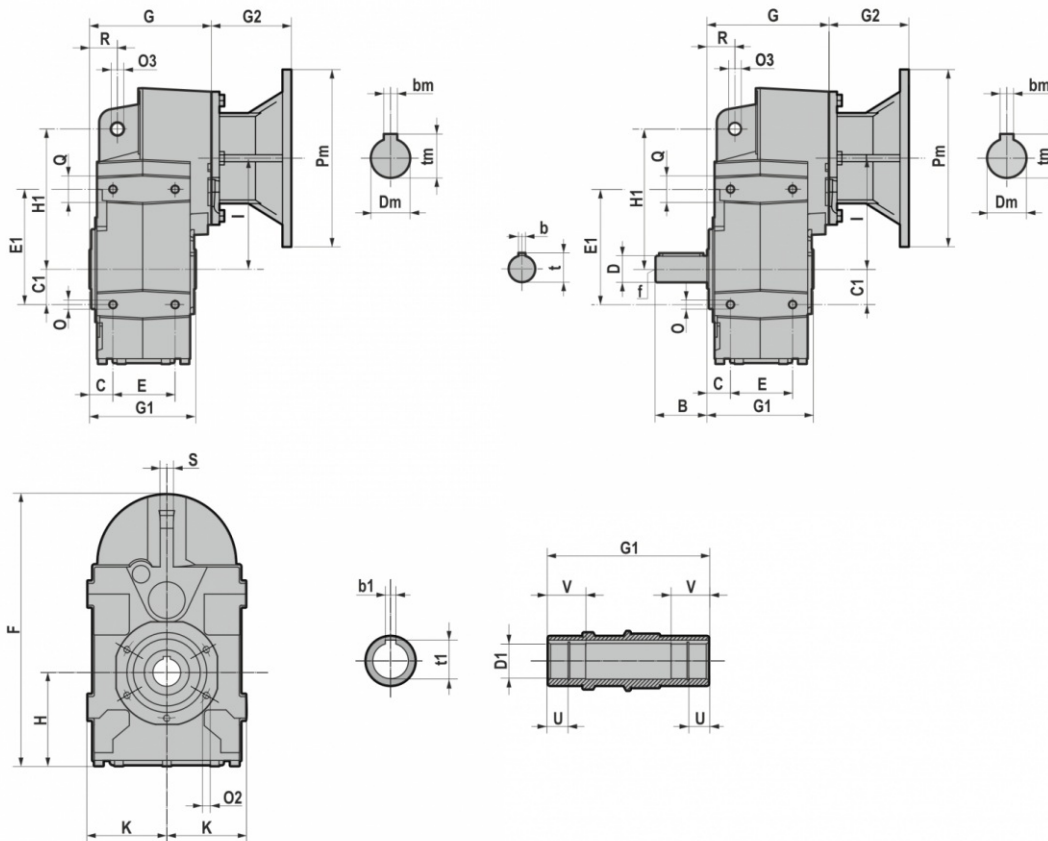

	D1 H7	b1	t1	U	V	B	D	b	t	f	C	C1	E	E1	F	G	G1	H	H1	I	K	O	O3	O2	Q	R	S
S052/S053	30	8	33	13,8	30	58	30 j6	8	33	M10	27	40	70	130	311	137,5	120	107	158	125	90,5	M10x18	14	M8x16 (n.5)	30	31,5	15
S062/S063	35	10	38	12	35	58	35 j6	10	38	M12	30	45	80	147	320	158,5	140	97	170	143	96,5	M12x20	14	M8x16 (n.5)	40	32	15
S082/S083	40	12	43	22,3	42	80	40 k6	12	43	M16	37	60	106	190	383	207	180	107	218	170	112,5	M12x20	14	M10x20 (n.7)	44	41	20
	45	14	47,6	22,3	42		50	50 k6	14	54	M16	37	70	137	275	426	217,5	210	119	278	180	130	M16x26	22	M12x22 (n.7)	50	50
S102/S103	45	14	49	22,3	50	100	50 k6	14	54	M16	37	70	137	275	426	217,5	210	119	278	180	130	M16x26	22	M12x22 (n.7)	50	50	20
	50	14	54	25	50		60 m6	18	64	M20	43	100	165	310	558	257	240	166	346	235	165	M16x30	22	M14x28 (n.7)	50	62	26
S122/S123	55	16	59,3	28	70	120	60 m6	18	64	M20	43	100	165	310	558	257	240	166	346	235	165	M16x30	22	M14x28 (n.7)	50	62	26
	60	18	64																								

IEC	Pm x Dm	G2				
		S052/S053	S062/S063	S082/S083	S102/S103	S122/S123
063	140x11	57	/	/	/	/
071	160x14	69	69	49	49	/
080	200x19	90	90	70	70	60,5
090	200x24	90	90	70	70	60,5
100-112	250x28	105	105	85	85	75,5
132	300x38	/	/	110	110	100,5
160	350x42	/	/	/	157,5	148
180	350x48	/	/	/	/	148
200	400x55	/	/	/	/	185

B5	Pm	Dm	bm	tm
063	140	11	4	12,8
071	160	14	5	16,3
080	200	19	6	21,8
090	200	24	8	27,3
100	250	28	8	31,3
112	250	28	8	31,3
132	300	38	10	41,3
160	350	42	12	45,3
180	350	48	14	51,8
200	400	55	16	59,3

3.1.2 S 142...153

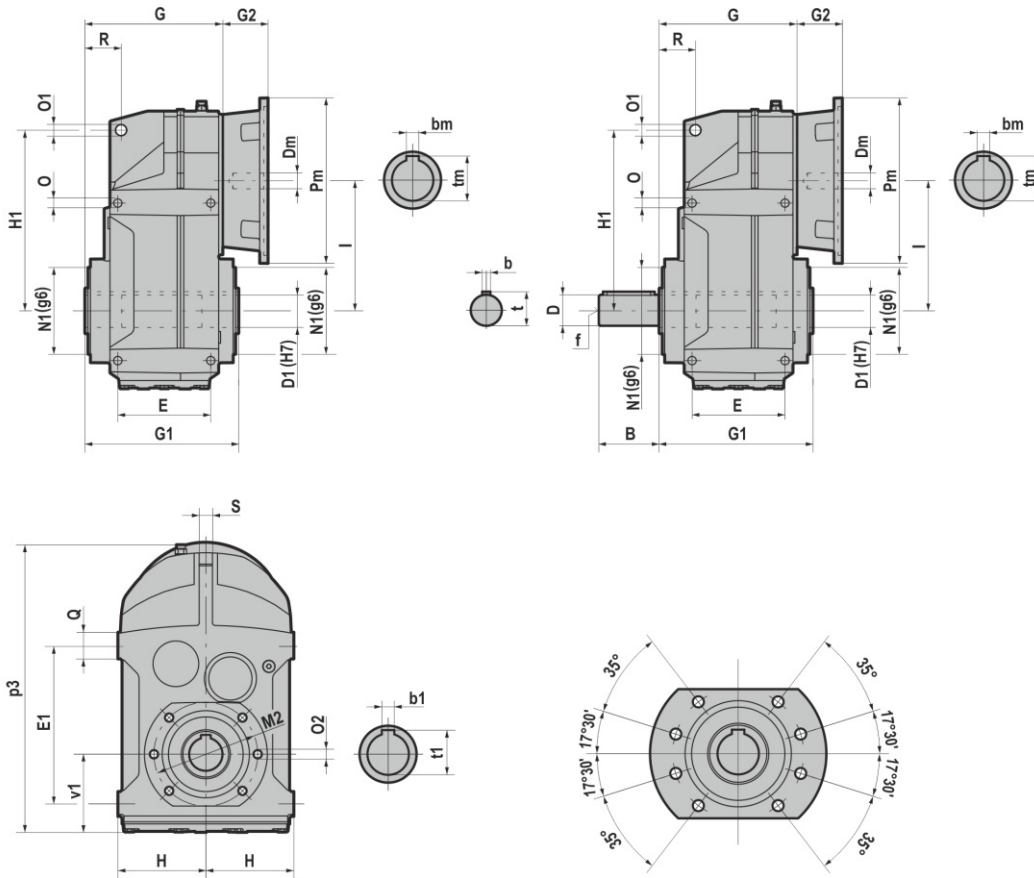

	D1	b1	t1	B	D	b	t	f	E	E1	G	G1	H	H1	I	N1	M2	O	O1	O2	p3	Q	R	S	v1
S142/S143	70	20	74,9	140	70	20	74,5	M20	205	350	282	300	200	395	269	180	220	M20x28	26	M16x26	615	50	70	30	177
	65	18	69,4																						
S152/S153	80	22	85,4	170	90	25	95	M20	220	400	321,5	350	225	485	325	210	260	M24x36	26	M20x30	730	60	88	36	213
	90	25	95,4																						

IEC	Pm x Dm	G2	
		S142/S143	S152/S153
100-112	250x28	73,5	/
132	300x38	84,0	87,5
160	350x42	119,5	112
180	350x48	119,5	112
200	400x55	119,5	113
225	450x60	/	144,5

B5	Pm	Dm	bm	tm
100	250	28	8	31,3
112	250	28	8	31,3
132	300	38	10	41,3
160	350	42	12	45,3
180	350	48	14	51,8
200	400	55	16	59,3
225	450	60	18	64,4

3.1.3 CS 052...123

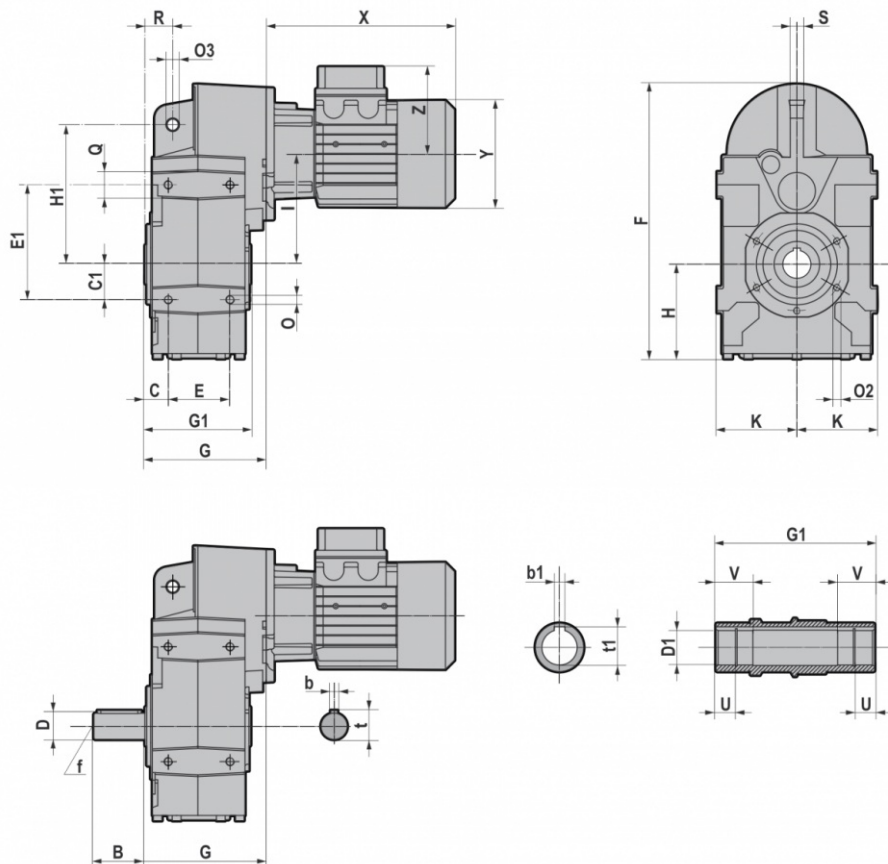

	D1 H7	b1	t1	U	V	B	D	b	t	f	C	C1	E	E1
CS052/CS053	30	8	33	13,8	30	58	30 j6	8	33	M10	27	40	70	130
CS062/CS063	35	10	38	12	35	58	35 j6	10	38	M12	30	45	80	147
CS082/CS083	40	12	43	22,3	42	80	40 k6	12	43	M16	37	60	106	190
	45	14	47,6	22,3	42									
CS102/CS103	45	14	49	22,3	50	100	50 k6	14	54	M16	37	70	137	275
	50	14	54	25	50									
CS122/CS123	55	16	59,3	28	70	120	60 m6	18	64	M20	43	100	165	310
	60	18	64											

	F	G	G1	H	H1	I	K	O	O3	O2	Q	R	S
CS052/CS053	311	137,5	120	107	158	125	90,5	M10x18	14	M8x16 (n.5)	30	31,5	15
CS062/CS063	320	158,5	140	97	170	143	96,5	M12x20	14	M8x16 (n.5)	40	32	15
CS082/CS083	383	207	180	107	218	170	112,5	M12x20	14	M10x20 (n.7)	44	41	20
CS102/CS103	426	217,5	210	119	278	180	130	M16x26	22	M12x22 (n.7)	50	50	20
CS122/CS123	558	257	240	166	346	235	165	M16x30	22	M14x28 (n.7)	50	62	26

3.1 REDUCERS/GEARED MOTORS

T (IE1 - IE2 - IE3)										
		063	071	080	090S	090L	100	112	132S	132M/L
CS052/CS053 CS062/CS063	X	215	241	268 *(291)	296 *(329)	321 *(354)	333	351 *(375)	/	/
	Y	121	139	158	173	173	191	211	/	/
	Z	104	112	122	130	130	139	154	/	/
CS082/CS083 CS102/CS103	X	/	221	248 *(271)	276 *(309)	301 *(334)	335	356 *(380)	405	443
	Y	/	139	158	173	173	191	211	249	249
	Z	/	112	122	130	130	139	154	194	194
CS122/CS123	X	/	/	/	267 *(300)	292 *(325)	326	347 *(371)	396	434
	Y	/	/	/	173	173	191	211	249	249
	Z	/	/	/	130	130	139	154	194	194

TB (IE1 - IE2 - IE3)										
		063	071	080	090S	090L	100	112	132S	132M/L
CS052/CS053 CS062/CS063	X	273	306,5	341 *(364)	373 *(406)	398 *(431)	415	448 *(472)	/	/
	Y	121	139	158	173	173	191	211	/	/
	Z	119	129	137	157	157	168	183	/	/
CS082/CS083 CS102/CS103	X	/	286,5	321 *(344)	353 *(386)	378 *(411)	417	453 *(477)	505	547
	Y	/	139	158	173	173	191	211	249	249
	Z	/	129	137	157	157	168	183	230	230
CS122/CS123	X	/	/	/	343 *(376)	368 *(401)	407	443 *(467)	495	537
	Y	/	/	/	173	173	191	211	249	249
	Z	/	/	/	157	157	168	183	230	230

*TP80B4, TP90S4, TP90L4, TP90S6, TP112M4, TP112M6

3.1.4 IS 052...123

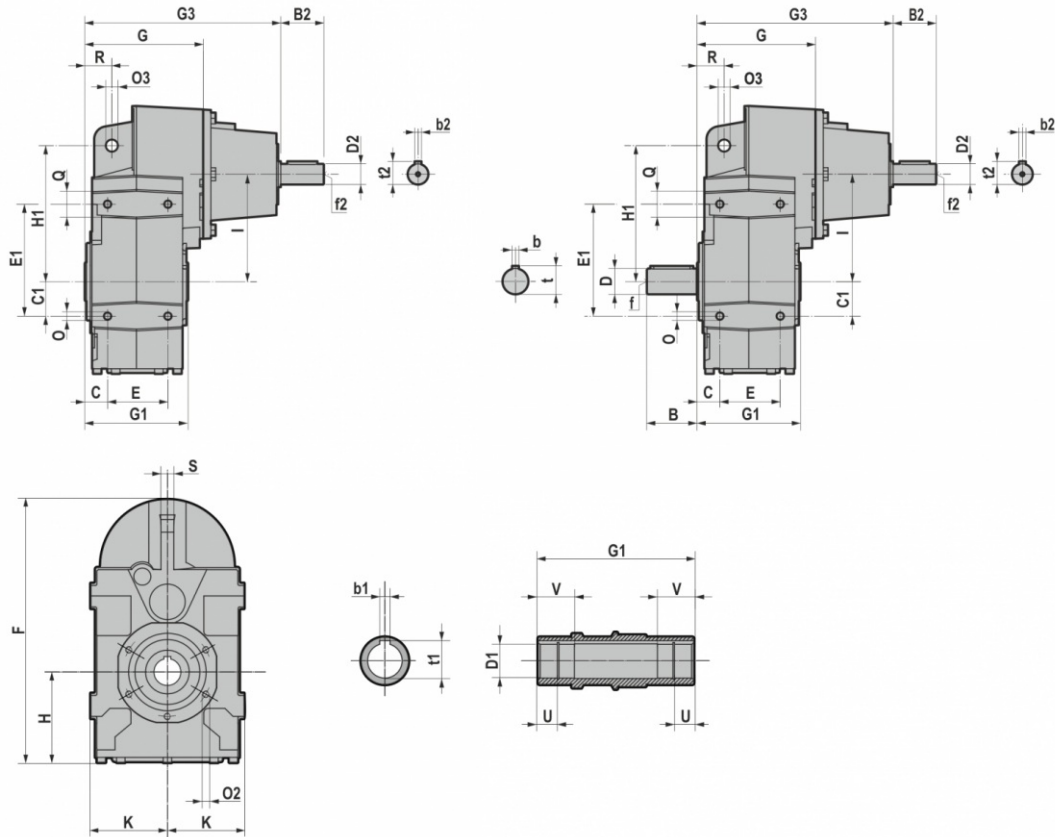

	D1 H7	b1	t1	U	V	B	D	b	t	f	C	C1	E	E1	F	G	G1	H	H1	I	K	O	O3	O2	Q	R	S
IS052/IS053	30	8	33	13,8	30	58	30 j6	8	33	M10	27	40	70	130	311	137,5	120	107	158	125	90,5	M10x18	14	M8x16 (n.5)	30	31,5	15
IS062/IS063	35	10	38	12	35	58	35 j6	10	38	M12	30	45	80	147	320	158,5	140	97	170	143	96,5	M12x20	14	M8x16 (n.5)	40	32	15
IS082/IS083	40 45	12 14	43 47,6	22,3 22,3	42 42	80	40 k6	12 12	43 43	M16	37 37	60 60	106 190	190 383	207	180	107	218	170	112,5	M12x20	14	M10x20 (n.7)	44	41	20	
IS102/IS103	45 50	14 14	49 54	22,3 25	50 50	100	50 k6	14 14	54 54	M16	37 37	70 70	137 275	275 426	426	217,5	210	119	278	180	130	M16x26	22	M12x22 (n.7)	50	50	20
IS122/IS123	55 60	16 18	59,3 64	28	70	120	60 m6	18 18	64 64	M20	43 43	100 100	165 310	310 558	558	257	240	166	346	235	165	M16x30	22	M14x28 (n.7)	50	62	26

	G3	B2	D2	b2	t2	f2
IS052/IS053	227,5	50	24 j6	8	27	M8
IS062/IS063	248,5	50	24 j6	8	27	M8
IS082/IS083	320	60	28 j6	8	31	M10
IS102/IS103	330,5	60	28 j6	8	31	M10
IS122/IS123	383,5	80	38 k6	10	41	M12

3.1.5 IS 142...153

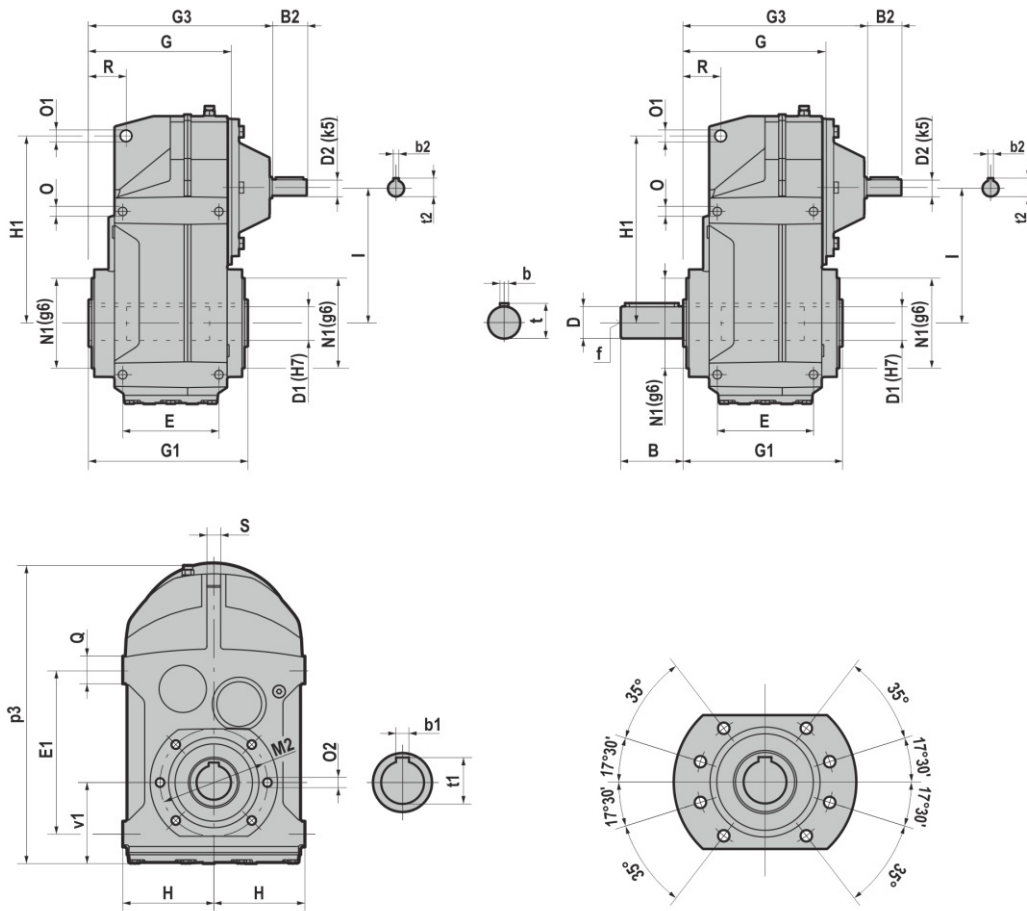

	D1	b1	t1	B	D	b	t	f	E	E1	G	G1	H	H1	I	N1	M2	O	O1	O2	p3	Q	R	S	v1
IS142/IS143	70	20	74,9	140	70	20	74,5	M20	205	350	282	300	200	395	269	180	220	M20x28	26	M16x26	615	50	70	30	177
	65	18	69,4																						
IS152/IS153	80	22	85,4	170	90	25	95	M20	220	400	321,5	350	225	485	325	210	260	M24x36	26	M20x30	730	60	88	36	213
	90	25	95,4																						

	G3	D2	B2	b2	t2
IS142/IS143	362	38	80	10	41
IS152/IS153	422	42	110	12	45

3.2.1 Electric motors

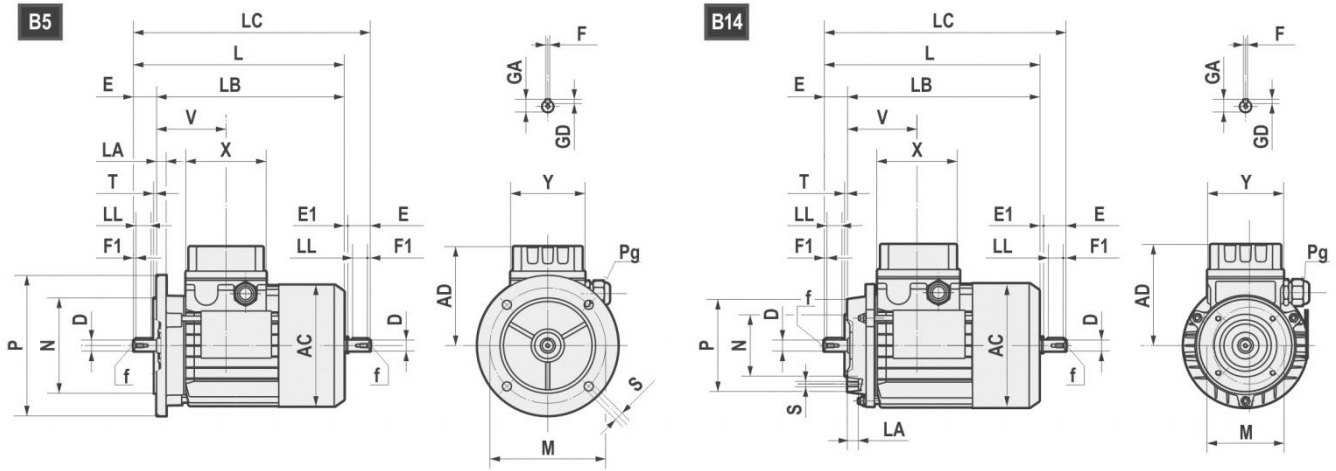

	AC	AD	L	LB	LC	X	Y	V	D	E	E1	f	F1	GA	F	GD
63	121	104	211	188	235,5	80	74	69	11 j6	23	1,5	M4x10	2,5	12,5	4	4
71	139	112	238,5	208,5	271	80	74	74,5	14 j6	30	2,5	M5x12.5	3	16	5	5
80	158	122	272,5 *(296)	232,5 *(256)	314 *(337)	80	74	78	19 j6	40	1,5	M6x16	5	21,5	6	6
90S	173	146	298 *(331)	248 *(281)	349,5 *(381)	98	98	89,5	24 j6	50	1,5	M8x19	5	27	8	7
90L	173	146	323 *(356)	273 *(306)	374,5 *(408)	98	98	89,5	24 j6	50	1,5	M8x19	5	27	8	7
100	191	155	368	308	431,5	98	98	97,5	28 j6	60	3,5	M10x22	7,5	31	8	7
112	211	170	382,5 *(408)	322,5 *(348)	447 *(472)	98	98	100	28 j6	60	3,5	M10x22	7,5	31	8	7
132S	249	195	452	372	536,5	118	118	115,5	38 k6	80	4	M12x28	10	41	10	8
132L	249	195	490	410	574,5	118	118	115,5	38 k6	80	4	M12x28	10	41	10	8
160S	249	195	520	410	/	118	118	115,5	42k6	100	/	M16x36	10	45	12	8

*TP80B4, TP90S4, TP90L4, TP90S6, TP112M4, TP112M6

B5	M	N	P	LA	S	T
63	115	95	140	10	9	3
71	130	110	160	10	9,5	3,5
80	165	130	200	12	11	3,5
90	165	130	200	12	11	3,5
100	215	180	250	15	14	4
112	215	180	250	14,5	14	4
132	265	230	300	20	14	3,5
160	300	250	350	13	18,5	3,5

B14	M	N	P	LA	S	T
63	75	60	90	10	M5	2,5
71	85	70	105	10,5	M6	2,5
80	100	80	120	10,5	M6	3
90	115	95	140	11,5	M8	3
100	130	110	160	15	M8	3,5
112	130	110	160	11,5	M8	3,5
132	165	130	200	20,5	M10	3,5
160	215	180	250	-	M12	4

3.2 ELECTRIC MOTORS

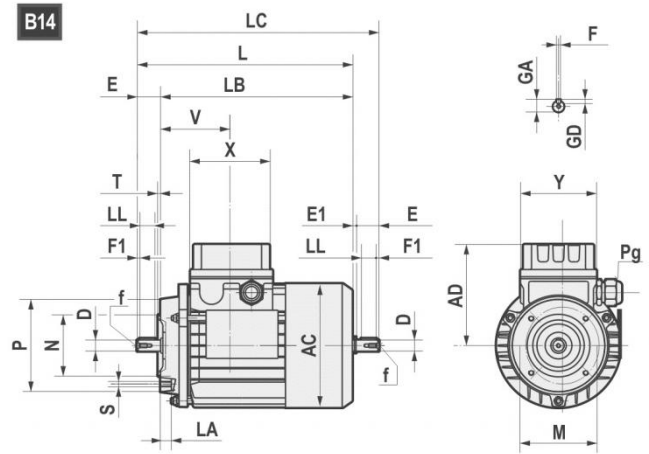
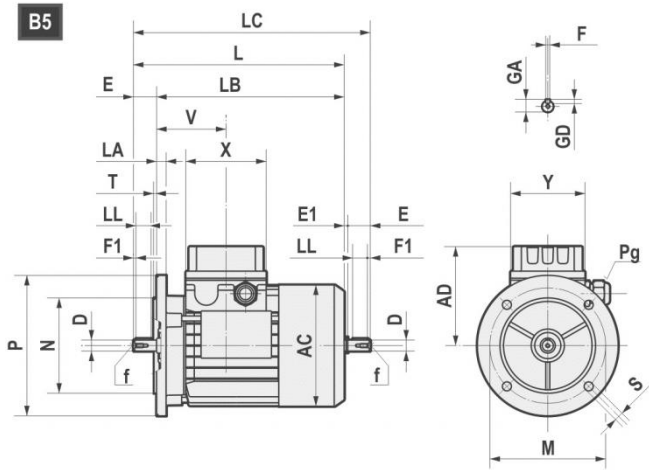

		AC	AD	L	LB	X	D	E	f	GA	F	GD	LL	Pg	
160M	2-4-6	314	251	600	490	158	42	110	M16	45	12	8	90	2-M40x1,5	1-M16x1,5
160L	2-4-6	314	251	645	535	158	42	110	M16	45	12	8	90	2-M40x1,5	1-M16x1,5
180M	2-4	355	267	680	570	158	48	110	M16	51,5	14	9	100	2-M40x1,5	1-M16x1,5
180L	4-6	355	267	720	610	158	48	110	M16	51,5	14	9	100	2-M40x1,5	1-M16x1,5
200L	2-4-6	397	300	785	675	187	55	110	M20	59	16	10	100	2-M50x1,5	1-M16x1,5
225S	4	446	325	820	680	187	60	140	M20	64	18	11	125	2-M50x1,5	1-M16x1,5
225M	2	446	325	815	705	187	55	110	M20	59	16	10	100	2-M50x1,5	1-M16x1,5
225M	4-6	446	325	845	705	187	60	140	M20	64	18	11	125	2-M50x1,5	1-M16x1,5
250M	2-4-6	485	360	910	770	238	60	140	M20	64	18	11	125	2-M63x1,5	1-M16x1,5
250M	2-4-6	485	360	910	770	238	65	140	M20	69	18	11	125	2-M63x1,5	1-M16x1,5
280S	2-4-6	547	390	970	830	238	65	140	M20	69	18	11	125	2-M63x1,5	1-M16x1,5
280S	2-4-6	547	390	970	830	238	75	140	M20	79,5	20	12	125	2-M63x1,5	1-M16x1,5
280M	2-4-6	547	390	1025	885	238	65	140	M20	69	18	11	125	2-M63x1,5	1-M16x1,5
280M	2-4-6	547	390	1025	885	238	75	140	M20	79,5	20	12	125	2-M63x1,5	1-M16x1,5

B5	M	N	P	LA	S	T
160	300	250	350	13	19	5
180	300	250	350	15	19	5
200	350	300	400	17	19	5
225	400	350	450	20	19	5
250	500	450	550	22	19	5
280	500	450	550	22	19	5

3.2.2 Standard high efficiency (TS), high (TH) and premium (TP) motors

Motovario, three-phase, single polarity motors are available in three different versions (IE1-IE2-IE3) in compliance with standard 60034-30-1 (see table). The efficiency value is calculated according to the method set forth in standard IEC 60034-2-1.

1. IE1: Standard efficiency TS series.
2. IE2: High efficiency TH series
3. IE3: Premium efficiency TP series.

Table of Motovario commercial availability

NOMINAL POWER [kW]	POLES	EFFICIENCY LEVEL		
		IE1	IE2	IE3
$0,09 \leq P_n < 0,75$	2 - 4 - 6	TS-TBS	-	-
$0,75 \leq P_n \leq 11$	2 - 4	TBS	-	-
$0,75 \leq P_n \leq 5,5$	6	TBS	TH-TBH	TP-TBP
$0,75 \leq P_n \leq 9,2$	2 - 4	-	TH-TBH	-
$0,75 \leq P_n \leq 7,5$	2 - 4	-	-	TP-TBP
$7,5 \leq P_n \leq 22$	6	TBS (*)	-	TP
$11 \leq P_n \leq 90$	4	-	-	TP
$15 \leq P_n \leq 37$	2	TBS (*)	-	TP
$15 \leq P_n \leq 55$	4	TBS (*)	-	-

(*) Series available on request.

3.2.3 Nominal power - [kW]

	63A	63B	63C	71A	71B	71C	80A			80B		
Poles	TS	TS	TS	TS	TS	TS	TS	TH	TP	TS	TH	TP
2	0,18	0,25	0,37	0,37	0,55	-	-	0,75	0,75	-	1,1	1,1
4	0,12	0,18	0,22	0,25	0,37	0,55	0,55	-	-	-	0,75	0,75
6	0,09	0,12	0,15	0,18	0,25	0,37	0,37	-	-	0,55	-	-

	90S		90L		100LR	100L	100LA		112MR	112MS	112MA	112M
Poles	TH	TP	TH	TP	TP	TP	TH	TP	TP	TP	TH	TP
2	1,5	1,5	2,2	2,2	-	3	3	-	-	-	4	4
4	1,1	1,1	1,5	1,5	-	-	2,2	2,2	2,2	3	4	4
6	-	0,75	0,75	-	1,1	1,5	1,1	-	-	-	2,2	2,2

	112MR	112MS	132S	132SA	132MS	132SB	132M	132MA		132MB	
Poles	TP	TP	TP	TH	TP	TH	TP	TH	TP	TH	TP
2	-	-	5,5	5,5	-	7,5	7,5	9,2	-	-	-
4	2,2	3	-	5,5	5,5	-	7,5	7,5	-	9,2	-
6	-	-	3	3	-	-	-	4	4	5,5	5,5

	160M	160MA	160MB	160L	160LA	180M	180L
Poles	TP	TP	TP	TP	TP	TP	TP
2	-	11	15	18,5	-	22	-
4	-	11	-	-	15	18,5	22
6	7,5	-	-	11	-	-	15

	200L	200LA	200LB	225S	225M	250M	280S	280M
Poles	TP	TP	TP	TP	TP	TP	TP	TP
2	-	30	37	-	-	-	-	-
4	30	-	-	37	45	55	75	90
6	-	18,5	22	-	-	-	-	-

3.3 WEIGHTS

The values reported in the tables are referred to the weight of the gearbox with lubricant (S140/S150 supplied without lubricant) included.

*Weight without motor.

* S-PS	063	071	080-090	100-112	132	160	180	200	225	
052-053	16	16,4	17	21,2	/	/	/	/	/	- kg
062-063	/	19,9	20,6	24,9	/	/	/	/	/	
082-083	/	32,9	35	37	39,7	/	/	/	/	
102-103	/	44	46	48	50,7	57,4	57,4	/	/	
122-123	/	/	82	84,2	87	93	93	108	/	
142	/	/	/	/	172	180	180	183	/	
143	/	/	/	175	183	190	/	/	/	
152	/	/	/	/	/	255	255	258	264	
153	/	/	/	/	250	270	270	/	/	

IS	- kg
052-053	19,2
062-063	22,7
082-083	39
102-103	50
122-123	91,8
142	155
143	165
152	220
153	240

CS	TS									
	063	071	080	090S	090L	100	112	132S		132M
052-053	19,5	20,4	25,1	29	31	36,5	48	/	/	- kg
062-063	/	23,9	28,7	32,6	34,6	40,1	51,6	/	/	
082-083	/	36,5	41,6	44	45,5	50,6	62	76	87,6	
102-103	/	47,5	52,6	55	56,5	61,6	73	87	98,6	
122-123	/	/	/	91	92	98	108	123	132	

CS	TH							
	080	090S	090L	100	112	132S	132M	
052-053	26,8	31,3	33	38,8	51,1	/	/	- kg
062-063	30,4	34,9	36,6	42,4	54,7	/	/	
082-083	43,3	46,3	47,5	52,9	65,1	81,3	94,4	
102-103	54,3	57,3	58,5	63,9	76,1	92,3	105,4	
122-123	/	93,3	94	100,3	111,1	128,3	138,8	

CS	TBS									
	063	071	080	090S	090L	100	112	132S		132M
052-053	21	22,6	28,6	34,5	36,5	42	57,7	/	/	- kg
062-063	/	26,2	32,2	38,1	40,1	45,6	61,3	/	/	
082-083	/	38,7	45	49,5	51	56	71,7	86,3	102,3	
102-103	/	49,7	56	60,5	62	67	82,7	97,3	113,3	
122-123	/	/	/	96,5	97,5	103,5	117,7	133,3	146,7	

CS	TBH							
	080	090S	090L	100	112	132S	132M	
052-053	30,3	36,8	38,5	45,7	60,8	/	/	- kg
062-063	33,9	40,4	42,1	49,3	64,4	/	/	
082-083	46,7	51,8	53	59,7	74,8	91,6	108,8	
102-103	57,7	62,8	64	70,7	85,8	102,6	119,8	
122-123	/	98,8	99,5	104	120,8	138,6	153,2	

3.4 SHAFT END

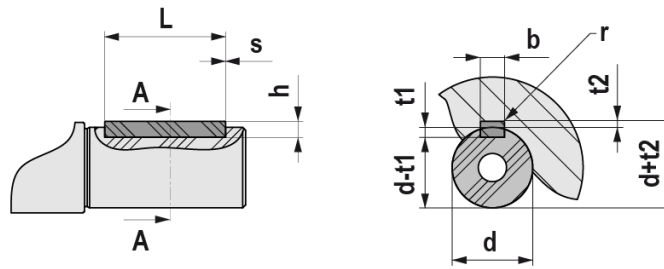

UNI 6604 - DIN 6885														
d		b x h			Tol. b/h	L		$\frac{s}{\min / \max}$	b	t1	t2	Tol. t1/t2	r max	
	6	8	2	x	2	h9 / h9	6	20	0,16 0,25	2	1,2	1	0,1 0	0,08 0,16
>	8	10	3	x	3		6	36		3	1,8	1,4		
>	10	12	4	x	4		8	45		4	2,5	1,8		
>	12	17	5	x	5		10	56	0,25 0,4	5	3	2,3		0,16 0,25
>	17	22	6	x	6		14	70		6	3	2,8		
>	22	30	8	x	7		18	90		8	4	3,3		
>	30	38	10	x	8	22	110	0,4 0,6	10	5	3,3	0,2 0	0,25 0,4	
>	38	44	12	x	8	28	140		12	5	3,3			
>	44	50	14	x	9	36	160		14	5,5	3,8			
>	50	58	16	x	10	45	180		16	6	4,3		0,4 0,6	
>	58	65	18	x	11	50	200		18	7	4,4			
>	65	75	20	x	12	56	110		20	7,5	4,9			
>	75	85	22	x	14	63	140	0,6 0,8	22	9	5,4	0,4 0,6		
>	85	95	25	x	14	70	160		25	9	5,4			
>	95	110	28	x	16	80	180		28	10	6,4			
>	110	130	32	x	18	90	200		32	11	7,4		0,3 0	
>	130	150	36	x	20	100	160		36	12	8,4			
>	150	170	40	x	22	110	180		40	13	9,4			
>	170	200	45	x	25	125	200	1,2	45	14	10,4	0,7 1		

4.1 LOW SPEED SHAFTS

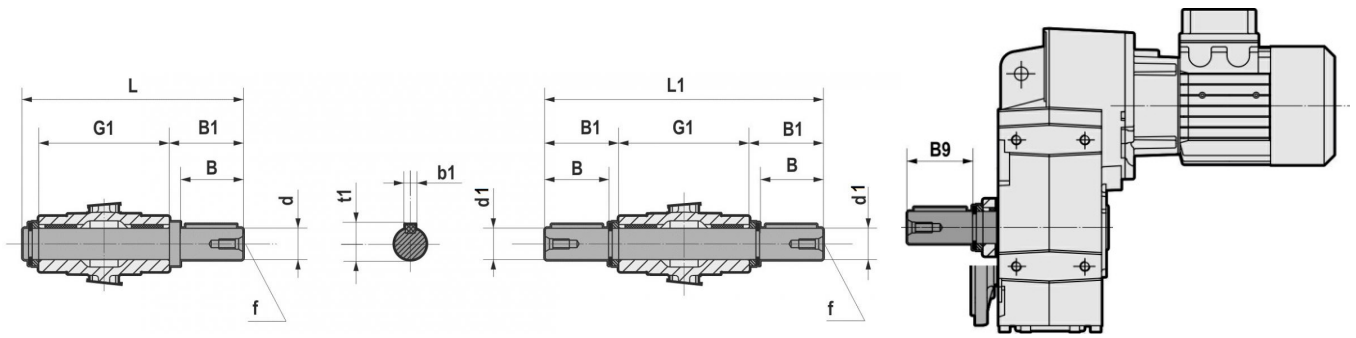

	d h6	B	B1	G1	L	f	b1	t1
S062/S063	35	58	62	140	210,5	M12	10	38
S082/S083	40	80	84,25	180	273	M16	12	43
S102/S103	50	100	105	210	325	M16	14	53,5
S122/S123	60	120	125	240	375	M20	18	64

	d k5	d1 h6	B	B1	B9	L1	f	b1	t1
S142/S143	70	70	140	150	197	600	M20	20	74,5
	65	65							69
S152/S153	90	90	170	180	221	710	M24	25	95
	80	80							M20

4.2 OUTPUT FLANGE

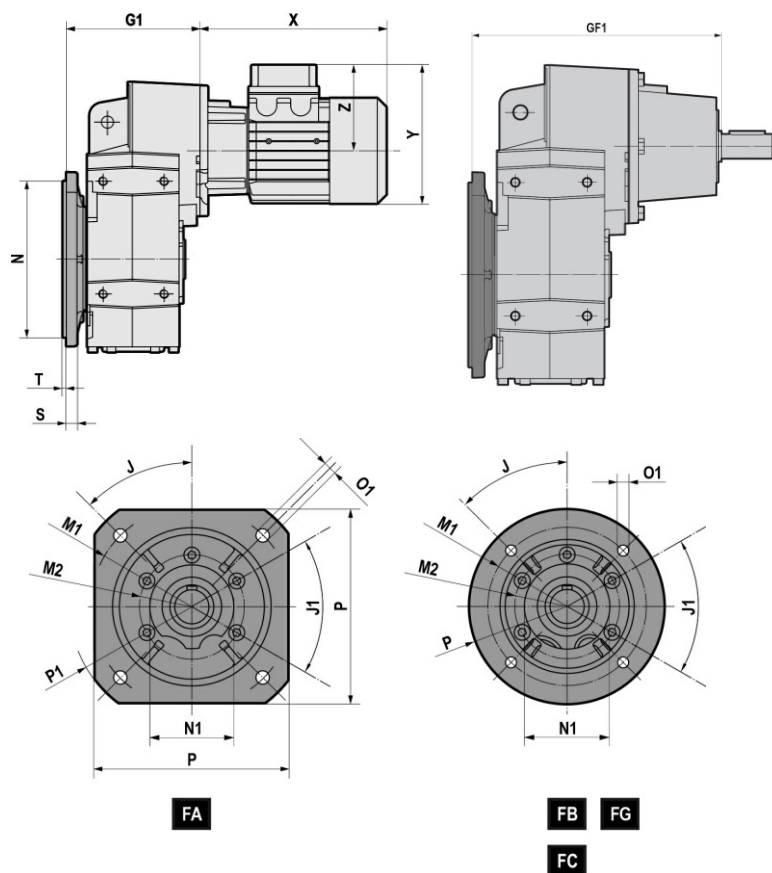

		J	J1	M1	M2	N f8	N1	O1	P	P1	S	T	G1	GF1
S052 S053	FA	45°	60°	215	105	180	90	14 (n.4)	200	250	12	4	153	243
	FB	45°	60°	165	105	130	90	11 (n.4)	200	/	12	3,5	153	243
S062 S063	FA	45°	60°	215	105	180	90	14 (n.4)	200	250	12	4	172,5	262,5
	FB	45°	60°	165	1050	130	90	11 (n.4)	200	/	12	3,5	172,5	262,5
S082 S083	FA	45°	45°	265	130	230	110	14 (n.4)	250	300	15	4	227	340
	FB	45°	45°	215	130	180	110	14 (n.4)	250	/	15	4	227	340
	FC	45°	45°	165	130	130	110	11 (n.4)	200	/	15	3,5	227	340
S102 S103	FA	45°	45°	300	165	250	130	18 (n.4)	300	350	16	5	247,5	360,5
	FB	45°	45°	265	165	230	130	14 (n.4)	300	/	16	4	247,5	360,5
	FC	45°	45°	215	165	180	130	14 (n.4)	250	/	16	4	247,5	360,5
S122 S123	FA	45°	45°	350	185	300	150	18 (n.4)	350	400	18	5	287	413,5
	FB	45°	45°	300	185	250	150	18 (n.4)	350	/	18	5	287	413,5
	FC	45°	45°	265	185	230	150	14 (n.4)	300	/	18	4	287	413,5
S142 S143	FG	22°30'	/	400	/	350 g6	/	18 (n.8)	450	/	20	5	338,5	426
S152 S153	FG	22°30'	/	400	/	350 g6	/	18 (n.8)	450	/	20	5	372,5	481

4.3.1 Reaction bolt

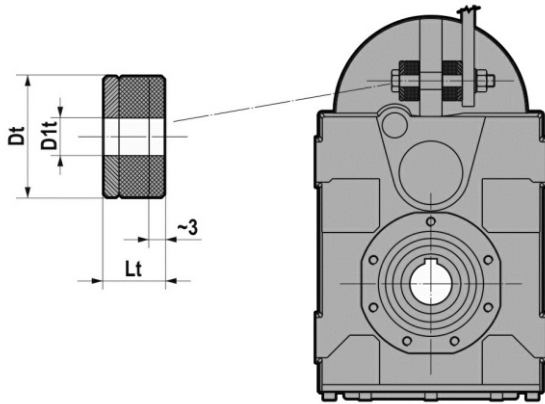

	Dt	D1t	Lt
S052/S053	40	12,5	20
S062/S063	40	12,5	20
S082/S083	40	12,5	20
S102/S103	60	21	30
S122/S123	60	21	30
S142/S143	60	25	38,8
S152/S153	60	25	35,5

4.3.2 Torque arm - S 142...153

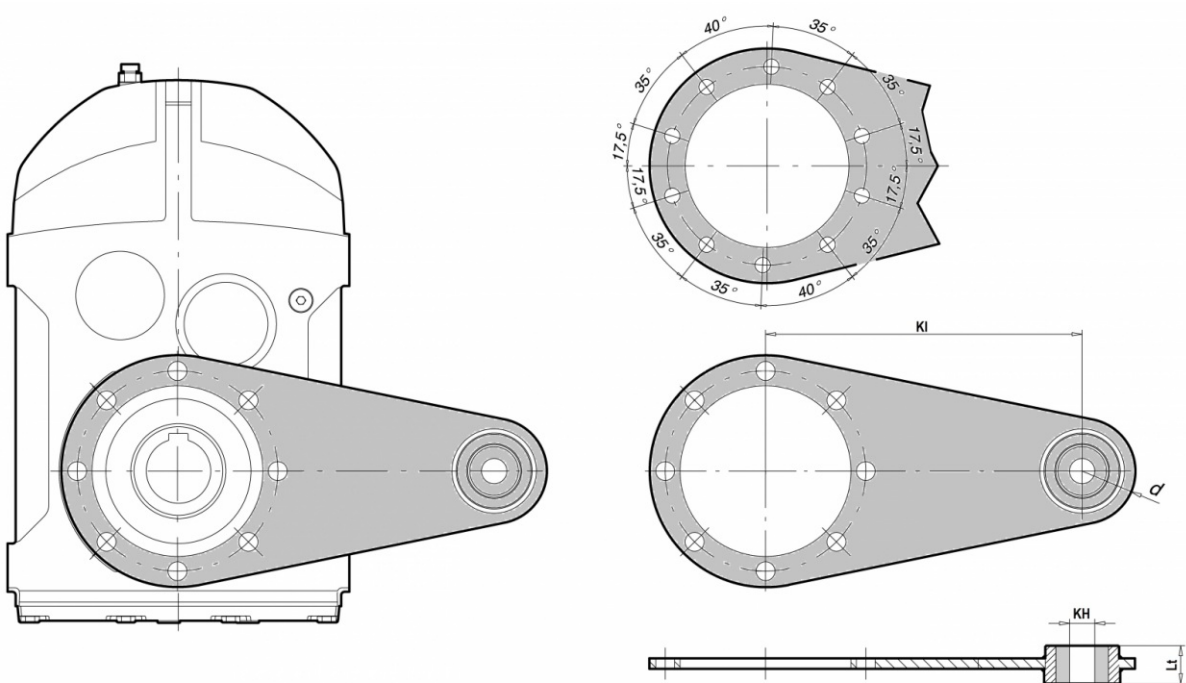

	KI	KH $\pm 0,2$	d	Lt
S142/S143	350	25	45	30
S152/S153	450	25	50	30

4.4 BACKSTOP DEVICE

The gear reducer can be supplied with backstop device on input shaft. Backstop device allows output shaft rotation in only one sense of direction; according to the size, it is available in the input flange or in the motor with the same dimensions. It is important to specify the required sense of direction on the order. The backstop device is not available for mounting position V5 with motor size IEC 100...225.

SENSE OF DIRECTION AVAILABLE

S... 2/C-D-L

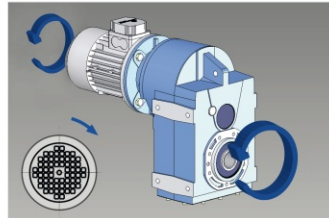

CLOCKWISE SENSE OF DIRECTION REFERRED TO HIGH SPEED SHAFT

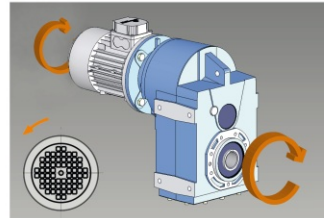

COUNTER CLOCKWISE SENSE OF DIRECTION REFERRED TO HIGH SPEED SHAFT

S... 3/C-D-L

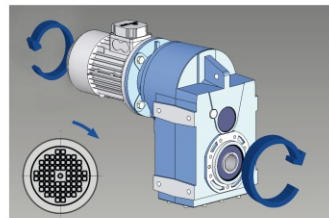

CLOCKWISE SENSE OF DIRECTION REFERRED TO HIGH SPEED SHAFT

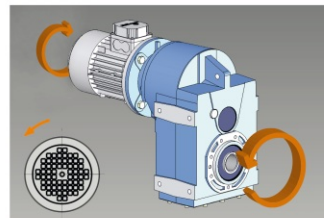

COUNTER CLOCKWISE SENSE OF DIRECTION REFERRED TO HIGH SPEED SHAFT

	063	071	080	090	100-112	132	160	180	200	225
	140x11	160x14	200x19	200x24	250x28	300x38	350x42	350x48	400x55	450x60
S052		B5	B5	B5	B5					
S053	B5	B5	B5	B5						
S062		B5	B5	B5	B5					
S063		B5	B5	B5						
S082			B5	B5	B5	B5				
S083		B5	B5	B5	B5					
S102			B5	B5	B5	B5	B5			
S103		B5	B5	B5	B5					
S122			B5	B5	B5	B5	B5	B5	B5	
S123			B5	B5	B5	B5				
S142						B5	B5	B5	B5	
S143					B5	B5	B5			
S152							B5	B5	B5	B5
S153						B5	B5	B5		

4.5 OUTPUT SHAFT WITH SHRINK DISC

Clean and degrease the surfaces of the shaft to be fitted to. Comply with the indicated tightening torque of screws (M_T). The shrink disc is designed only to transmit the output torque. In case of radial and/or axial loads or V5-V6 mounting positions, please contact the technical support.

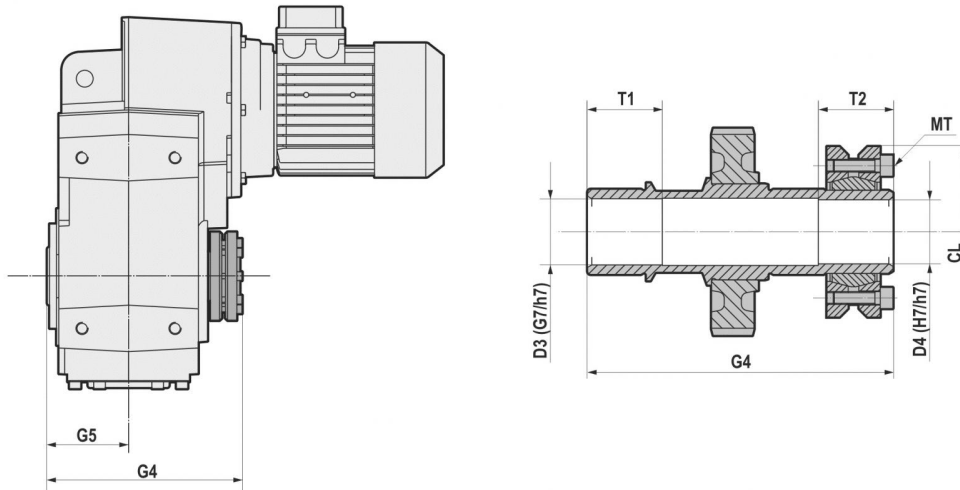

	D3	D4	G4	G5	T1	T2	CL	M_T 12.9 [Nm]
S052/S053	31	30	152	60	35	35	74	15
S062/S063	36	35	173	70	40	35	80	15
S082/S083	41	40	217	90	50	40	100	15
S102/S103	51	50	248	105	55	40	115	15
S122/S123	61	60	282	120	60	50	145	40

	D3 - D4 (H7/h6)	G4	CL	M_T 12.9 [Nm]
S142-S143	75	345	155	70
S152-S153	95	405	200	103
	80		185	

4.6 REINFORCED OIL SEALS FOR OUTPUT SHAFT

The reinforced seal can be done depending on the gearbox size by means of two oil seals or through the standard oil seal with VRM ring. The difference of the two solutions is explained on the drawings.

On request the gear reducer can be supplied with fluoroelastomer FPM (FKM) seals.

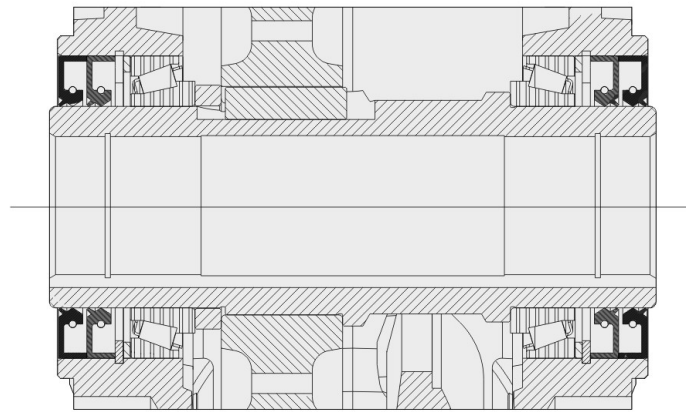
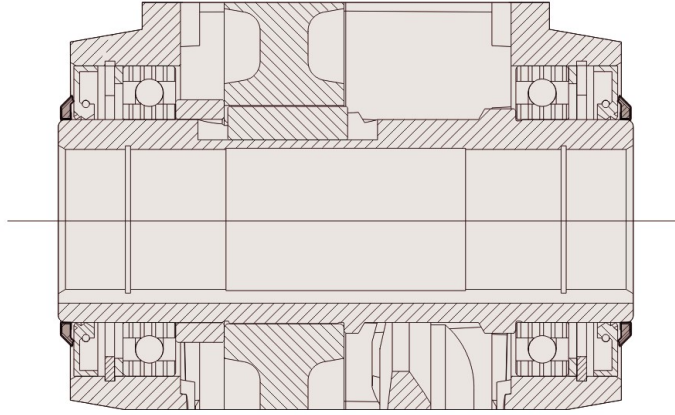

	Double oil seal	VRM ring
S050 2/3		x
S060 2/3		x
S080 2/3		x
S100 2/3		x
S125 2/3		x
S140 2/3		x
S150 2/3	x	

4.7 ASSEMBLING/DISASSEMBLING KIT

Mounting/dismounting kit for hollow shaft gear reducers with keyway that includes:

1. Retaining bolt
2. Circlip
3. Fixed nut
4. Forcing washer

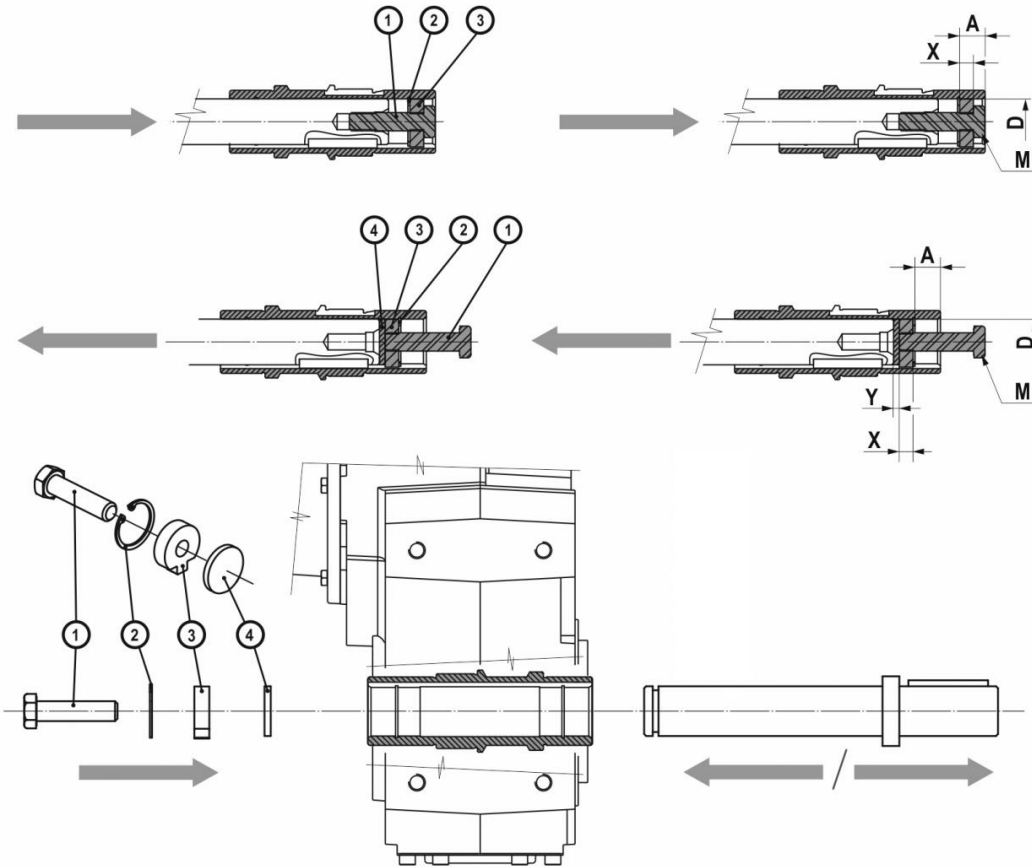

	D	A	X	Y	M
S052/S053	30	13,8	10	5	M10x35
S062/S063	35	12	12	5	M16x50
S082/S083	40	22,25	12	5	M16x50
	45				
S102/S103	50	25	12	5	M16x50
S122/S123	60	28	16	5	M20x70

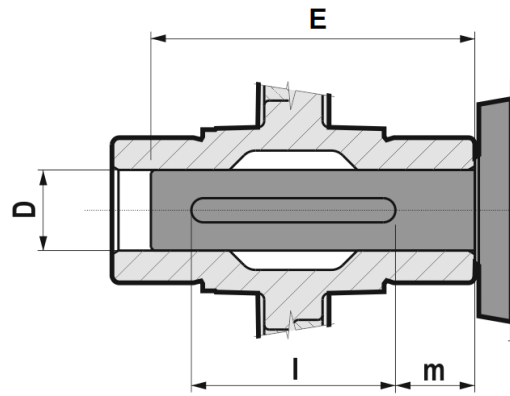

	D H7/h6	E*	l*	m*
S052/S053	30	85	60	12,5
S062/S063	35	105	80	12,5
S082/S083	40	135	100	17,5
	45			
S102/S103	50	160	120	20
S122/S123	60	185	140	22,5

(*) Suggested values.

0,09 kW

n2 [rpm]	M2 [Nm]	fs	i	Gear reducer	Size	Motor Pole	Fr2 D [N]	Fr2 C-L [N]
7,3	111	3,3	117,48	S053	63A	6	6000	6000
6,3	130	2,8	137,45	S053	63A	6	6000	6000
4,8	168	2,2	177,55	S053	63A	6	6000	6000
4,3	188	2,0	198,45	S053	63A	6	6000	6000
4,0	207	1,8	217,64	S053	63A	6	6000	6000
3,4	243	1,5	256,33	S053	63A	6	6000	6000
2,7	298	1,2	314,21	S053	63A	6	6000	6000

0,12 kW

n2 [rpm]	M2 [Nm]	fs	i	Gear reducer	Size	Motor Pole	Fr2 D [N]	Fr2 C-L [N]
11,6	94	3,9	74,20	S053	63B	6	6000	6000
11,4	94	3,7	117,48	S053	63A	4	6000	6000
11,0	99	3,7	78,14	S053	63B	6	6000	6000
9,7	111	3,2	137,45	S053	63A	4	6000	6000
9,0	121	3,0	95,84	S053	63B	6	6000	6000
7,5	143	2,5	177,55	S053	63A	4	6000	6000
7,3	149	2,5	117,48	S053	63B	6	6000	6000
6,8	160	2,2	198,45	S053	63A	4	6000	6000
6,3	174	2,1	137,45	S053	63B	6	6000	6000
6,2	175	2,0	217,64	S053	63A	4	6000	6000
5,2	206	1,7	256,33	S053	63A	4	6000	6000
4,8	225	1,6	177,55	S053	63B	6	6000	6000
4,3	251	1,5	198,45	S053	63B	6	6000	6000
4,3	253	1,4	314,21	S053	63A	4	6000	6000
4,0	275	1,3	217,64	S053	63B	6	6000	6000
3,4	324	1,1	256,33	S053	63B	6	6000	6000
2,7	398	0,9	314,21	S053	63B	6	6000	6000

0,15 kW

n2 [rpm]	M2 [Nm]	fs	i	Gear reducer	Size	Motor Pole	Fr2 D [N]	Fr2 C-L [N]
14,0	97	3,8	57,79	S053	63C	6	6000	6000
12,7	107	3,4	63,74	S053	63C	6	6000	6000
10,9	125	2,9	74,20	S053	63C	6	6000	6000
10,4	131	2,8	78,14	S053	63C	6	6000	6000
8,5	161	2,3	95,84	S053	63C	6	6000	6000
6,9	197	1,9	117,48	S053	63C	6	6000	6000
5,9	231	1,6	137,45	S053	63C	6	6000	6000
4,6	298	1,2	177,55	S053	63C	6	6000	6000
4,1	333	1,1	198,45	S053	63C	6	6000	6000

5.1 S GEARED MOTORS (50Hz)

0,15 kW

n2 [rpm]	M2 [Nm]	fs	i	Gear reducer	Size	Motor	Pole	Fr2 D [N]	Fr2 C-L [N]
3,7	365	1,0	217,64	S053	63C		6	6000	6000

0,18 kW

n2 [rpm]	M2 [Nm]	fs	i	Gear reducer	Size	Motor	Pole	Fr2 D [N]	Fr2 C-L [N]
20,4	77	3,4	137,45	S053	63A		2	6000	6000
17,9	90	3,9	74,20	S053	63B		4	6000	6000
17,2	97	3,8	52,25	S052	71A		6	6000	6000
17,0	95	3,7	78,14	S053	63B		4	6000	6000
15,8	99	2,7	177,55	S053	63A		2	6000	6000
15,6	107	3,4	57,86	S052	71A		6	6000	6000
15,6	105	3,5	57,79	S053	71A		6	6000	6000
15,1	110	3,3	59,42	S052	71A		6	6000	6000
14,1	116	3,2	63,74	S053	71A		6	6000	6000
14,1	111	2,4	198,45	S053	63A		2	6000	6000
13,9	116	3,0	95,84	S053	63B		4	6000	6000
12,9	121	2,2	217,64	S053	63A		2	6000	6000
12,4	135	2,7	72,83	S052	71A		6	6000	6000
12,1	135	2,7	74,20	S053	71A		6	6000	6000
11,5	142	2,6	78,14	S053	71A		6	6000	6000
11,3	143	2,5	117,48	S053	63B		4	6000	6000
10,9	143	1,8	256,33	S053	63A		2	6000	6000
9,7	167	2,1	137,45	S053	63B		4	6000	6000
9,4	174	2,1	95,84	S053	71A		6	6000	6000
9,0	181	3,5	99,89	S063	71A		6	10000	4000
8,9	175	1,5	314,21	S053	63A		2	6000	6000
7,7	213	1,7	117,48	S053	71A		6	6000	6000
7,5	216	1,6	177,55	S053	63B		4	6000	6000
7,1	229	2,7	126,43	S063	71A		6	10000	4000
6,7	241	1,5	198,45	S053	63B		4	6000	6000
6,5	249	1,5	137,45	S053	71A		6	6000	6000
6,1	264	1,3	217,64	S053	63B		4	6000	6000
6,0	274	2,3	150,85	S063	71A		6	10000	4000
5,7	288	3,6	158,76	S083	71A		6	18000	7200
5,2	311	1,1	256,33	S053	63B		4	6000	6000
5,1	322	1,1	177,55	S053	71A		6	6000	6000
4,9	331	1,9	182,53	S063	71A		6	10000	4000
4,9	336	1,9	185,05	S063	71A		6	10000	4000
4,9	335	3,1	184,88	S083	71A		6	18000	7200
4,5	360	1,0	198,45	S053	71A		6	6000	6000
4,4	368	2,9	203,11	S083	71A		6	18000	7200
4,4	372	2,8	205,34	S083	71A		6	18000	7200

5.1 S GEARED MOTORS (50Hz)

0,18 kW

n2 [rpm]	M2 [Nm]	fs	i	Gear reducer	Size	Motor Pole	Fr2 D [N]	Fr2 C-L [N]
4,2	382	0,9	314,21	S053	63B	4	6000	6000
4,1	395	0,9	217,64	S053	71A	6	6000	6000
4,1	395	1,6	217,79	S063	71A	6	10000	4000
4,0	410	2,6	226,04	S083	71A	6	18000	7200
3,6	454	2,3	250,50	S083	71A	6	18000	7200
3,4	484	1,3	267,16	S063	71A	6	10000	4000
3,4	483	2,2	266,13	S083	71A	6	18000	7200
3,3	497	3,4	274,20	S103	71A	6	22000	9000
3,2	509	3,3	280,89	S103	71A	6	22000	9000
3,1	530	2,0	292,36	S083	71A	6	18000	7200
3,1	530	3,2	292,36	S103	71A	6	22000	9000
2,9	573	1,8	315,73	S083	71A	6	18000	7200
2,8	582	2,9	320,79	S103	71A	6	22000	9000
2,6	627	2,7	345,60	S103	71A	6	22000	9000
2,5	654	1,6	360,58	S083	71A	6	18000	7200
2,3	716	2,3	394,69	S103	71A	6	22000	9000

0,22 kW

n2 [rpm]	M2 [Nm]	fs	i	Gear reducer	Size	Motor Pole	Fr2 D [N]	Fr2 C-L [N]
20,9	95	3,7	63,74	S053	63C	4	6000	6000
17,9	110	3,2	74,20	S053	63C	4	6000	6000
17,0	116	3,0	78,14	S053	63C	4	6000	6000
13,9	142	2,5	95,84	S053	63C	4	6000	6000
11,3	174	2,0	117,48	S053	63C	4	6000	6000
9,7	204	1,7	137,45	S053	63C	4	6000	6000
7,5	264	1,3	177,55	S053	63C	4	6000	6000
6,7	295	1,2	198,45	S053	63C	4	6000	6000
6,1	323	1,1	217,64	S053	63C	4	6000	6000
5,2	381	0,9	256,33	S053	63C	4	6000	6000

0,25 kW

n2 [rpm]	M2 [Nm]	fs	i	Gear reducer	Size	Motor Pole	Fr2 D [N]	Fr2 C-L [N]
30,0	77	3,9	30,00	S052	71B	6	6000	6000
29,2	74	3,5	95,84	S053	63B	2	6000	6000
27,6	84	3,8	32,55	S052	71B	6	6000	6000
27,3	85	3,7	33,00	S052	71B	6	6000	6000
26,4	88	3,6	34,09	S052	71B	6	6000	6000
24,7	92	4,0	36,50	S053	71B	6	6000	6000
24,6	94	3,7	36,55	S052	71B	6	6000	6000

5.1 S GEARED MOTORS (50Hz)

0,25 kW

n2 [rpm]	M2 [Nm]	fs	i	Gear reducer	Motor Size	Pole	Fr2 D [N]	Fr2 C-L [N]
24,0	95	3,7	57,86	S052	71A	4	6000	6000
23,8	91	2,9	117,48	S053	63B	2	6000	6000
23,4	98	3,6	59,42	S052	71A	4	6000	6000
23,2	100	3,5	38,75	S052	71B	6	6000	6000
22,8	98	3,6	57,79	S053	63D/71A	4	6000	6000
22,6	103	3,6	39,90	S052	71B	6	6000	6000
21,1	110	3,4	42,63	S052	71B	6	6000	6000
20,7	108	3,2	63,74	S053	63D/71A	4	6000	6000
20,4	106	2,5	137,45	S053	63B	2	6000	6000
19,6	118	3,1	46,00	S052	71B	6	6000	6000
19,1	121	3,0	47,20	S052	71B	6	6000	6000
19,1	120	2,9	72,83	S052	71A	4	6000	6000
19,1	119	3,1	47,14	S053	71B	6	6000	6000
17,8	126	2,8	74,20	S053	63D/71A	4	6000	6000
17,2	134	2,7	52,25	S052	71B	6	6000	6000
16,9	133	2,6	78,14	S053	63D/71A	4	6000	6000
15,8	137	1,9	177,55	S053	63B	2	6000	6000
15,6	149	2,5	57,86	S052	71B	6	6000	6000
15,6	146	2,5	57,79	S053	71B	6	6000	6000
15,1	153	2,4	59,42	S052	71B	6	6000	6000
14,1	161	2,3	63,74	S053	71B	6	6000	6000
14,1	153	1,7	198,45	S053	63B	2	6000	6000
13,9	161	3,7	99,89	S063	71A	4	10000	4000
13,8	163	2,1	95,84	S053	63D/71A	4	6000	6000
13,7	166	3,8	65,85	S063	71B	6	10000	4000
13,3	174	3,6	67,47	S062	71B	6	10000	4000
13,2	172	3,7	68,25	S063	71B	6	10000	4000
12,9	168	1,6	217,64	S053	63B	2	6000	6000
12,4	187	2,0	72,83	S052	71B	6	6000	6000
12,2	185	3,4	73,63	S063	71B	6	10000	4000
12,1	187	2,0	74,20	S053	71B	6	6000	6000
11,5	197	1,9	78,14	S053	71B	6	6000	6000
11,2	200	1,8	117,48	S053	63D/71A	4	6000	6000
11,1	205	3,1	81,43	S063	71B	6	10000	4000
11,0	204	2,9	126,43	S063	71A	4	10000	4000
10,9	198	1,3	256,33	S053	63B	2	6000	6000
9,6	234	1,5	137,45	S053	63D/71A	4	6000	6000
9,4	241	1,5	95,84	S053	71B	6	6000	6000
9,2	244	2,5	150,85	S063	71A	4	10000	4000
9,0	252	2,5	99,89	S063	71B	6	10000	4000
8,9	243	1,1	314,21	S053	63B	2	6000	6000
8,8	256	3,9	158,76	S083	71A	4	18000	7200

0,25 kW

n2 [rpm]	M2 [Nm]	fs	i	Gear reducer	Motor Size	Pole	Fr2 D [N]	Fr2 C-L [N]
7,7	296	1,2	117,48	S053	71B	6	6000	6000
7,7	295	3,6	117,17	S083	71B	6	18000	7200
7,6	295	2,0	182,53	S063	71A	4	10000	4000
7,5	299	2,0	185,05	S063	71A	4	10000	4000
7,5	299	3,4	184,88	S083	71A	4	18000	7200
7,4	302	1,2	177,55	S053	63D/71A	4	6000	6000
7,1	318	2,0	126,43	S063	71B	6	10000	4000
7,0	324	3,2	128,73	S083	71B	6	18000	7200
6,8	328	3,0	203,11	S083	71A	4	18000	7200
6,8	332	3,0	205,34	S083	71A	4	18000	7200
6,7	337	1,0	198,45	S053	63D/71A	4	6000	6000
6,6	343	3,1	136,34	S083	71B	6	18000	7200
6,5	346	1,1	137,45	S053	71B	6	6000	6000
6,4	352	1,7	217,79	S063	71A	4	10000	4000
6,1	370	0,9	217,64	S053	63D/71A	4	6000	6000
6,1	365	2,7	226,04	S083	71A	4	18000	7200
6,0	380	1,7	150,85	S063	71B	6	10000	4000
5,7	400	2,6	158,76	S083	71B	6	18000	7200
5,5	404	2,5	250,50	S083	71A	4	18000	7200
5,2	431	1,4	267,16	S063	71A	4	10000	4000
5,2	430	2,3	266,13	S083	71A	4	18000	7200
5,2	438	3,8	173,78	S103	71B	6	22000	9000
5,1	443	3,6	274,20	S103	71A	4	22000	9000
4,9	460	1,4	182,53	S063	71B	6	10000	4000
4,9	466	1,4	185,05	S063	71B	6	10000	4000
4,9	466	2,3	184,88	S083	71B	6	18000	7200
4,9	454	3,5	280,89	S103	71A	4	22000	9000
4,8	472	2,1	292,36	S083	71A	4	18000	7200
4,8	475	3,5	188,51	S103	71B	6	22000	9000
4,8	472	3,4	292,36	S103	71A	4	22000	9000
4,4	512	2,1	203,11	S083	71B	6	18000	7200
4,4	517	2,0	205,34	S083	71B	6	18000	7200
4,4	510	2,0	315,73	S083	71A	4	18000	7200
4,4	512	3,3	203,11	S103	71B	6	22000	9000
4,3	518	3,1	320,79	S103	71A	4	22000	9000
4,1	549	1,1	217,79	S063	71B	6	10000	4000
4,0	569	1,8	226,04	S083	71B	6	18000	7200
4,0	558	2,9	345,60	S103	71A	4	22000	9000
4,0	561	3,0	222,85	S103	71B	6	22000	9000
4,0	566	3,0	224,76	S103	71B	6	22000	9000
3,9	582	1,7	360,58	S083	71A	4	18000	7200
3,6	631	1,7	250,50	S083	71B	6	18000	7200

0,25 kW

n2 [rpm]	M2 [Nm]	fs	i	Gear reducer	Size	Motor Pole	Fr2 D [N]	Fr2 C-L [N]
3,5	637	2,5	394,69	S103	71A	4	22000	9000
3,4	673	0,9	267,16	S063	71B	6	10000	4000
3,4	670	1,6	266,13	S083	71B	6	18000	7200
3,3	691	2,4	274,20	S103	71B	6	22000	9000
3,2	707	2,4	280,89	S103	71B	6	22000	9000
3,1	736	1,4	292,36	S083	71B	6	18000	7200
3,1	736	2,3	292,36	S103	71B	6	22000	9000
2,9	795	1,3	315,73	S083	71B	6	18000	7200
2,8	808	2,1	320,79	S103	71B	6	22000	9000
2,6	870	1,9	345,60	S103	71B	6	22000	9000
2,5	908	1,2	360,58	S083	71B	6	18000	7200
2,3	994	1,7	394,69	S103	71B	6	22000	9000

0,37 kW

n2 [rpm]	M2 [Nm]	fs	i	Gear reducer	Size	Motor Pole	Fr2 D [N]	Fr2 C-L [N]
54,0	63	4,0	16,29	S052	71C	6	5904	5904
48,7	67	3,9	57,86	S052	71A	2	6000	6000
48,3	66	4,0	57,79	S053	63C/71A	2	6000	6000
47,5	69	3,8	59,42	S052	71A	2	6000	6000
47,2	73	3,5	18,63	S052	71C/80A	6	6000	6000
46,0	74	3,9	30,00	S052	71B	4	6000	6000
44,6	77	3,3	19,73	S052	71C/80A	6	6000	6000
43,8	73	3,6	63,74	S053	63C/71A	2	6000	6000
42,4	80	3,7	32,55	S052	71B	4	6000	6000
41,8	82	3,3	21,04	S052	71C/80A	6	6000	6000
41,8	81	3,7	33,00	S052	71B	4	6000	6000
40,9	84	3,3	21,53	S052	71C/80A	6	6000	6000
40,5	84	3,6	34,09	S052	71B	4	6000	6000
38,7	85	3,1	72,83	S052	71A	2	6000	6000
37,8	90	3,7	36,55	S052	71B	4	6000	6000
37,8	88	4,0	36,50	S053	71B	4	6000	6000
37,6	85	3,1	74,20	S053	63C/71A	2	6000	6000
36,6	94	2,9	24,07	S052	71C/80A	6	6000	6000
35,7	90	2,9	78,14	S053	63C/71A	2	6000	6000
35,6	95	3,5	38,75	S052	71B	4	6000	6000
34,9	98	3,1	25,20	S052	71C/80A	6	6000	6000
34,6	98	3,6	39,90	S052	71B	4	6000	6000
34,1	100	3,0	25,79	S052	71C/80A	6	6000	6000
32,4	105	3,3	42,63	S052	71B	4	6000	6000
31,6	108	2,8	27,81	S052	71C/80A	6	6000	6000
30,0	113	3,1	46,00	S052	71B	4	6000	6000

0,37 kW

n2 [rpm]	M2 [Nm]	fs	i	Gear reducer	Motor Size	Pole	Fr2 D [N]	Fr2 C-L [N]
29,3	117	2,6	30,00	S052	71C/80A	6	6000	6000
29,3	113	3,1	47,14	S053	71B	4	6000	6000
29,2	116	3,0	47,20	S052	71B	4	6000	6000
29,1	110	2,4	95,84	S053	63C/71A	2	6000	6000
28,2	114	4,0	99,89	S063	71A	2	10000	4000
27,0	127	2,5	32,55	S052	71C/80A	6	6000	6000
26,7	128	2,5	33,00	S052	71C/80A	6	6000	6000
26,4	128	2,7	52,25	S052	71B	4	6000	6000
25,8	133	2,4	34,09	S052	71C/80A	6	6000	6000
24,1	142	2,4	36,55	S052	71C/80A	6	6000	6000
24,1	139	2,6	36,50	S053	71C/80A	6	6000	6000
23,9	139	2,5	57,79	S053	71B	4	6000	6000
23,8	142	2,5	57,86	S052	71B	4	6000	6000
23,7	135	1,9	117,48	S053	63C/71A	2	6000	6000
23,2	146	2,4	59,42	S052	71B	4	6000	6000
22,7	151	2,3	38,75	S052	71C/80A	6	6000	6000
22,3	144	3,1	126,43	S063	71A	2	10000	4000
22,1	155	2,4	39,90	S052	71C/80A	6	6000	6000
21,6	153	2,3	63,74	S053	71B	4	6000	6000
21,0	158	3,8	65,85	S063	71B	4	10000	4000
20,6	166	2,2	42,63	S052	71C/80A	6	6000	6000
20,5	166	3,6	67,47	S062	71B	4	10000	4000
20,3	158	1,7	137,45	S053	63C/71A	2	6000	6000
20,2	170	3,7	43,64	S062	71C/80A	6	10000	4000
20,2	164	3,7	68,25	S063	71B	4	10000	4000
19,1	179	2,1	46,00	S052	71C/80A	6	6000	6000
19,1	179	3,5	46,10	S062	71C/80A	6	10000	4000
18,9	179	2,0	72,83	S052	71B	4	6000	6000
18,7	180	2,0	47,14	S053	71C/80A	6	6000	6000
18,7	177	3,4	73,63	S063	71B	4	10000	4000
18,7	171	2,6	150,85	S063	71A	2	10000	4000
18,6	184	2,0	47,20	S052	71C/80A	6	6000	6000
18,6	179	2,0	74,20	S053	71B	4	6000	6000
18,2	188	3,4	48,30	S062	71C/80A	6	10000	4000
17,9	187	3,4	49,13	S063	71C/80A	6	10000	4000
17,7	188	1,9	78,14	S053	71B	4	6000	6000
16,9	196	3,1	81,43	S063	71B	4	10000	4000
16,8	203	1,8	52,25	S052	71C/80A	6	6000	6000
16,4	208	3,0	53,53	S062	71C/80A	6	10000	4000
16,0	214	2,9	55,00	S062	71C/80A	6	10000	4000
15,9	211	3,0	55,29	S063	71C/80A	6	10000	4000
15,7	204	1,3	177,55	S053	63C/71A	2	6000	6000

0,37 kW

n2 [rpm]	M2 [Nm]	fs	i	Gear reducer	Motor Size	Pole	Fr2 D [N]	Fr2 C-L [N]
15,4	207	2,2	182,53	S063	71A	2	10000	4000
15,3	210	3,6	184,88	S083	71A	2	18000	7200
15,2	225	1,6	57,86	S052	71C/80A	6	6000	6000
15,2	220	1,7	57,79	S053	71C/80A	6	6000	6000
15,2	210	2,1	185,05	S063	71A	2	10000	4000
15,0	224	2,8	58,72	S063	71C/80A	6	10000	4000
14,8	231	1,6	59,42	S052	71C/80A	6	6000	6000
14,4	231	1,5	95,84	S053	71B	4	6000	6000
14,1	228	1,2	198,45	S053	63C/71A	2	6000	6000
13,9	231	3,2	203,11	S083	71A	2	18000	7200
13,8	243	1,5	63,74	S053	71C/80A	6	6000	6000
13,8	240	2,5	99,89	S063	71B	4	10000	4000
13,7	233	3,2	205,34	S083	71A	2	18000	7200
13,4	251	2,5	65,85	S063	71C/80A	6	10000	4000
13,0	263	2,4	67,47	S062	71C/80A	6	10000	4000
12,9	260	2,4	68,25	S063	71C/80A	6	10000	4000
12,9	248	1,8	217,79	S063	71A	2	10000	4000
12,8	250	1,0	217,64	S053	63C/71A	2	6000	6000
12,7	265	4,0	74,18	S083	80A	6	18000	7200
12,5	257	2,9	226,04	S083	71A	2	18000	7200
12,1	284	1,3	72,83	S052	71C/80A	6	6000	6000
12,0	281	2,2	73,63	S063	71C/80A	6	10000	4000
11,9	283	1,3	74,20	S053	71C/80A	6	6000	6000
11,8	282	3,5	117,17	S083	71B	4	18000	7200
11,7	283	1,2	117,48	S053	71B	4	6000	6000
11,5	292	3,6	81,71	S083	80A	6	18000	7200
11,3	298	1,2	78,14	S053	71C/80A	6	6000	6000
11,3	285	2,6	250,50	S083	71A	2	18000	7200
10,9	304	2,0	126,43	S063	71B	4	10000	4000
10,8	310	2,0	81,43	S063	71C/80A	6	10000	4000
10,7	310	3,2	128,73	S083	71B	4	18000	7200
10,6	304	1,5	267,16	S063	71A	2	10000	4000
10,6	302	2,5	266,13	S083	71A	2	18000	7200
10,3	327	3,2	91,49	S083	80A	6	18000	7200
10,3	312	3,9	274,20	S103	71A	2	22000	9000
10,1	328	3,0	136,34	S083	71B	4	18000	7200
10,0	331	1,1	137,45	S053	71B	4	6000	6000
10,0	319	3,8	280,89	S103	71A	2	22000	9000
9,6	332	2,3	292,36	S083	71A	2	18000	7200
9,6	332	3,6	292,36	S103	71A	2	22000	9000
9,3	359	2,9	100,62	S083	80A	6	18000	7200
9,2	365	1,0	95,84	S053	71C/80A	6	6000	6000

0,37 kW

n2 [rpm]	M2 [Nm]	fs	i	Gear reducer	Motor Size	Pole	Fr2 D [N]	Fr2 C-L [N]
9,1	363	1,7	150,85	S063	71B	4	10000	4000
8,9	359	2,1	315,73	S083	71A	2	18000	7200
8,8	381	1,7	99,89	S063	71C/80A	6	10000	4000
8,8	365	3,3	320,79	S103	71A	2	22000	9000
8,7	382	2,6	158,76	S083	71B	4	18000	7200
8,2	393	3,1	345,60	S103	71A	2	22000	9000
8,0	421	4,0	110,55	S103	71C	6	22000	9000
7,9	418	3,8	173,78	S103	71B	4	22000	9000
7,8	410	1,8	360,58	S083	71A	2	18000	7200
7,6	439	1,4	182,53	S063	71B	4	10000	4000
7,5	445	1,3	185,05	S063	71B	4	10000	4000
7,5	447	2,4	117,17	S083	71C/80A	6	18000	7200
7,5	445	2,2	184,88	S083	71B	4	18000	7200
7,3	462	3,6	121,29	S103	71C/80A	6	22000	9000
7,3	454	3,5	188,51	S103	71B	4	22000	9000
7,1	449	2,7	394,69	S103	71A	2	22000	9000
7,0	482	1,3	126,43	S063	71C/80A	6	10000	4000
6,8	491	2,1	128,73	S083	71C/80A	6	18000	7200
6,8	489	2,0	203,11	S083	71B	4	18000	7200
6,8	491	3,4	128,73	S103	71C/80A	6	22000	9000
6,8	489	3,3	203,11	S103	71B	4	22000	9000
6,7	494	2,0	205,34	S083	71B	4	18000	7200
6,5	520	2,0	136,34	S083	71C/80A	6	18000	7200
6,3	524	1,1	217,79	S063	71B	4	10000	4000
6,2	538	3,1	141,24	S103	71C/80A	6	22000	9000
6,2	536	3,0	222,85	S103	71B	4	22000	9000
6,1	544	1,8	226,04	S083	71B	4	18000	7200
6,1	541	3,0	224,76	S103	71B	4	22000	9000
5,8	575	1,1	150,85	S063	71C/80A	6	10000	4000
5,5	605	1,7	158,76	S083	71C/80A	6	18000	7200
5,5	603	1,7	250,50	S083	71B	4	18000	7200
5,2	643	0,9	267,16	S063	71B	4	10000	4000
5,2	641	1,6	266,13	S083	71B	4	18000	7200
5,1	660	1,0	185,05	S063	80A	6	10000	4000
5,1	662	2,5	173,78	S103	71C/80A	6	22000	9000
5,0	660	2,4	274,20	S103	71B	4	22000	9000
4,9	676	2,4	280,89	S103	71B	4	22000	9000
4,8	696	0,9	182,53	S063	71C/80A	6	10000	4000
4,8	705	1,5	184,88	S083	71C/80A	6	18000	7200
4,7	704	1,4	292,36	S083	71B	4	18000	7200
4,7	704	2,3	292,36	S103	71B	4	22000	9000
4,7	719	2,3	188,51	S103	71C/80A	6	22000	9000

0,37 kW

n2 [rpm]	M2 [Nm]	fs	i	Gear reducer	Size	Motor Pole	Fr2 D [N]	Fr2 C-L [N]
4,4	760	1,3	315,73	S083	71B	4	18000	7200
4,3	774	1,4	203,11	S083	71C/80A	6	18000	7200
4,3	783	1,3	205,34	S083	71C/80A	6	18000	7200
4,3	774	2,2	203,11	S103	71C/80A	6	22000	9000
4,3	772	2,1	320,79	S103	71B	4	22000	9000
4,0	832	1,9	345,60	S103	71B	4	22000	9000
3,9	862	1,2	226,04	S083	71C/80A	6	18000	7200
3,9	850	2,0	222,85	S103	71C/80A	6	22000	9000
3,9	857	2,0	224,76	S103	71C/80A	6	22000	9000
3,9	853	3,7	238,93	S123	80A	6	30000	11200
3,8	868	1,2	360,58	S083	71B	4	18000	7200
3,7	912	3,5	255,54	S123	80A	6	30000	11200
3,5	955	1,1	250,50	S083	71C/80A	6	18000	7200
3,5	950	1,7	394,69	S103	71B	4	22000	9000
3,4	1000	3,2	280,10	S123	80A	6	30000	11200
3,3	1015	1,0	266,13	S083	71C/80A	6	18000	7200
3,2	1045	1,6	274,20	S103	71C/80A	6	22000	9000
3,1	1071	1,6	280,89	S103	71C/80A	6	22000	9000
3,1	1075	2,9	301,16	S123	80A	6	30000	11200
3,0	1115	0,9	292,36	S083	71C/80A	6	18000	7200
3,0	1127	0,9	315,73	S083	80A	6	18000	7200
3,0	1115	1,5	292,36	S103	71C/80A	6	22000	9000
2,7	1223	1,4	320,79	S103	71C/80A	6	22000	9000
2,7	1227	2,6	343,93	S123	80A	6	30000	11200
2,5	1317	1,3	345,60	S103	71C/80A	6	22000	9000
2,2	1505	1,1	394,69	S103	71C/80A	6	22000	9000

0,55 kW

n2 [rpm]	M2 [Nm]	fs	i	Gear reducer	Size	Motor Pole	Fr2 D [N]	Fr2 C-L [N]
107,8	47	3,8	8,63	S052	80B	6	4719	4719
86,3	56	4,0	32,55	S052	71B	2	5046	5046
85,2	57	3,9	33,00	S052	71B	2	5066	5066
83,5	61	3,3	11,14	S052	80B	6	5079	5079
82,4	59	3,8	34,09	S052	71B	2	5113	5113
77,5	66	3,2	12,00	S052	80B	6	5187	5187
76,9	63	3,9	36,55	S052	71B	2	5215	5215
73,5	69	3,5	18,63	S052	71C/80A	4	5267	5267
72,5	67	3,7	38,75	S052	71B	2	5302	5302
70,4	69	3,8	39,90	S052	71B	2	5346	5346
69,4	73	3,3	19,73	S052	71C/80A	4	5352	5352
68,1	75	2,9	13,66	S052	80B	6	5377	5377

0,55 kW

n2 [rpm]	M2 [Nm]	fs	i	Gear reducer	Motor Size	Pole	Fr2 D [N]	Fr2 C-L [N]
65,9	74	3,6	42,63	S052	71B	2	5445	5445
65,1	77	3,4	21,04	S052	71C/80A	4	5448	5448
63,6	79	3,3	21,53	S052	71C/80A	4	5482	5482
61,1	80	3,3	46,00	S052	71B	2	5561	5561
60,9	84	3,0	15,27	S052	80B	6	5544	5544
59,6	80	3,3	47,14	S053	71B	2	5608	5608
59,5	82	3,2	47,20	S052	71B	2	5600	5600
57,1	89	2,8	16,29	S052	80B	6	5641	5641
56,9	89	2,9	24,07	S052	71C/80A	4	5651	5651
54,4	93	3,1	25,20	S052	71C/80A	4	5721	5721
53,8	90	2,9	52,25	S052	71B	2	5756	5756
53,1	95	3,1	25,79	S052	71C/80A	4	5756	5756
49,9	102	2,5	18,63	S052	80B	6	5846	5846
49,3	102	2,8	27,81	S052	71C/80A	4	5872	5872
48,6	100	2,6	57,86	S052	71B	2	5915	5915
48,6	98	2,7	57,79	S053	71B	2	5925	5925
47,3	103	2,6	59,42	S052	71B	2	5956	5956
47,1	108	2,3	19,73	S052	80B	6	5933	5933
45,7	110	2,6	30,00	S052	71C/80A	4	5989	5989
44,2	115	2,4	21,04	S052	80B	6	6000	6000
44,1	108	2,4	63,74	S053	71B	2	6000	6000
43,2	118	2,3	21,53	S052	80B	6	6000	6000
42,1	120	2,5	32,55	S052	71C/80A	4	6000	6000
41,7	117	3,9	67,47	S062	71B	2	10000	4000
41,5	121	2,5	33,00	S052	71C/80A	4	6000	6000
41,2	116	3,9	68,25	S063	71B	2	10000	4000
40,2	125	2,4	34,09	S052	71C/80A	4	6000	6000
40,1	127	3,9	23,18	S062	80B	6	10000	4000
39,2	130	3,8	23,75	S062	80B	6	10000	4000
38,6	132	2,1	24,07	S052	80B	6	6000	6000
38,6	126	2,1	72,83	S052	71B	2	6000	6000
38,2	125	3,6	73,63	S063	71B	2	10000	4000
37,9	126	2,1	74,20	S053	71B	2	6000	6000
37,5	135	2,5	36,55	S052	71C/80A	4	6000	6000
37,5	132	2,7	36,50	S053	71C/80A	4	6000	6000
37,0	138	3,7	25,14	S062	80B	6	10000	4000
36,9	138	2,2	25,20	S052	80B	6	6000	6000
36,1	141	2,2	25,79	S052	80B	6	6000	6000
36,0	132	2,0	78,14	S053	71B	2	6000	6000
35,4	143	2,3	38,75	S052	71C/80A	4	6000	6000
34,5	138	3,3	81,43	S063	71B	2	10000	4000
34,3	147	2,4	39,90	S052	71C/80A	4	6000	6000

0,55 kW

n2 [rpm]	M2 [Nm]	fs	i	Gear reducer	Motor Size	Pole	Fr2 D [N]	Fr2 C-L [N]
33,6	151	3,3	27,66	S062	80B	6	10000	4000
33,4	152	2,0	27,81	S052	80B	6	6000	6000
32,1	157	2,2	42,63	S052	71C/80A	4	6000	6000
31,4	161	3,7	43,64	S062	71C/80A	4	10000	4000
31,0	164	1,9	30,00	S052	80B	6	6000	6000
31,0	164	3,2	30,00	S062	80B	6	10000	4000
29,8	169	2,1	46,00	S052	71C/80A	4	6000	6000
29,7	170	3,5	46,10	S062	71C/80A	4	10000	4000
29,3	163	1,6	95,84	S053	71B	2	6000	6000
29,1	170	2,1	47,14	S053	71C/80A	4	6000	6000
29,0	174	2,0	47,20	S052	71C/80A	4	6000	6000
28,6	178	1,8	32,55	S052	80B	6	6000	6000
28,4	178	3,4	48,30	S062	71C/80A	4	10000	4000
28,2	181	1,7	33,00	S052	80B	6	6000	6000
28,1	169	2,7	99,89	S063	71B	2	10000	4000
27,9	177	3,4	49,13	S063	71C/80A	4	10000	4000
27,7	180	3,5	33,57	S063	80B	6	10000	4000
27,4	186	3,1	33,93	S062	80B	6	10000	4000
27,3	187	1,7	34,09	S052	80B	6	6000	6000
26,2	192	1,8	52,25	S052	71C/80A	4	6000	6000
25,6	197	3,0	53,53	S062	71C/80A	4	10000	4000
25,5	196	1,9	36,50	S053	80B	6	6000	6000
25,4	200	1,7	36,55	S052	80B	6	6000	6000
25,4	200	3,1	36,57	S062	80B	6	10000	4000
24,9	202	3,0	55,00	S062	71C/80A	4	10000	4000
24,8	199	3,0	55,29	S063	71C/80A	4	10000	4000
24,6	203	3,1	37,77	S063	80B	6	10000	4000
24,0	212	1,6	38,75	S052	80B	6	6000	6000
24,0	199	3,8	117,17	S083	71B	2	18000	7200
23,9	199	1,3	117,48	S053	71B	2	6000	6000
23,7	213	1,6	57,86	S052	71C/80A	4	6000	6000
23,7	208	1,7	57,79	S053	71C/80A	4	6000	6000
23,6	216	2,9	39,38	S062	80B	6	10000	4000
23,3	218	1,7	39,90	S052	80B	6	6000	6000
23,3	212	2,8	58,72	S063	71C/80A	4	10000	4000
23,2	215	2,9	40,05	S063	80B	6	10000	4000
23,1	219	1,6	59,42	S052	71C/80A	4	6000	6000
22,2	214	2,1	126,43	S063	71B	2	10000	4000
21,8	233	1,6	42,63	S052	80B	6	6000	6000
21,8	218	3,4	128,73	S083	71B	2	18000	7200
21,5	230	1,5	63,74	S053	71C/80A	4	6000	6000
21,3	239	2,6	43,64	S062	80B	6	10000	4000

0,55 kW

n2 [rpm]	M2 [Nm]	fs	i	Gear reducer	Motor Size	Pole	Fr2 D [N]	Fr2 C-L [N]
20,8	237	2,5	65,85	S063	71C/80A	4	10000	4000
20,6	231	3,2	136,34	S083	71B	2	18000	7200
20,4	233	1,1	137,45	S053	71B	2	6000	6000
20,3	248	2,4	67,47	S062	71C/80A	4	10000	4000
20,2	252	1,5	46,00	S052	80B	6	6000	6000
20,2	252	2,5	46,10	S062	80B	6	10000	4000
20,1	246	2,4	68,25	S063	71C/80A	4	10000	4000
19,7	258	1,4	47,20	S052	80B	6	6000	6000
19,7	253	1,5	47,14	S053	80B	6	6000	6000
19,3	264	2,4	48,30	S062	80B	6	10000	4000
18,9	263	2,4	49,13	S063	80B	6	10000	4000
18,9	262	3,8	74,18	S083	80A	4	18000	7200
18,8	268	1,3	72,83	S052	71C/80A	4	6000	6000
18,6	265	2,3	73,63	S063	71C/80A	4	10000	4000
18,6	256	1,8	150,85	S063	71B	2	10000	4000
18,5	267	1,3	74,20	S053	71C/80A	4	6000	6000
18,5	275	3,8	50,25	S082	80B	6	18000	7200
17,8	286	1,3	52,25	S052	80B	6	6000	6000
17,7	269	2,8	158,76	S083	71B	2	18000	7200
17,5	282	1,2	78,14	S053	71C/80A	4	6000	6000
17,4	293	2,1	53,53	S062	80B	6	10000	4000
17,1	297	3,5	54,27	S082	80B	6	18000	7200
17,1	288	3,5	81,71	S083	80A	4	18000	7200
16,9	301	2,1	55,00	S062	80B	6	10000	4000
16,8	296	2,1	55,29	S063	80B	6	10000	4000
16,8	293	2,0	81,43	S063	71C/80A	4	10000	4000
16,1	317	1,2	57,86	S052	80B	6	6000	6000
16,1	310	1,2	57,79	S053	80B	6	6000	6000
15,8	315	2,0	58,72	S063	80B	6	10000	4000
15,7	325	1,1	59,42	S052	80B	6	6000	6000
15,4	309	1,5	182,53	S063	71B	2	10000	4000
15,3	323	3,1	91,49	S083	80A	4	18000	7200
15,2	314	1,4	185,05	S063	71B	2	10000	4000
15,2	313	2,4	184,88	S083	71B	2	18000	7200
15,0	339	3,1	61,98	S082	80B	6	18000	7200
14,9	320	3,8	188,51	S103	71B	2	22000	9000
14,6	342	1,1	63,74	S053	80B	6	6000	6000
14,3	345	1,0	95,84	S053	71C/80A	4	6000	6000
14,1	353	1,8	65,85	S063	80B	6	10000	4000
13,9	355	2,8	100,62	S083	80A	4	18000	7200
13,8	369	1,7	67,47	S062	80B	6	10000	4000
13,8	362	2,9	67,52	S083	80B	6	18000	7200

0,55 kW

n2 [rpm]	M2 [Nm]	fs	i	Gear reducer	Motor Size	Pole	Fr2 D [N]	Fr2 C-L [N]
13,8	344	2,2	203,11	S083	71B	2	18000	7200
13,8	344	3,5	203,11	S103	71B	2	22000	9000
13,7	360	1,7	99,89	S063	71C/80A	4	10000	4000
13,7	348	2,2	205,34	S083	71B	2	18000	7200
13,6	366	1,7	68,25	S063	80B	6	10000	4000
12,9	369	1,2	217,79	S063	71B	2	10000	4000
12,8	399	0,9	72,83	S052	80B	6	6000	6000
12,6	395	1,6	73,63	S063	80B	6	10000	4000
12,6	378	3,2	222,85	S103	71B	2	22000	9000
12,5	398	0,9	74,20	S053	80B	6	6000	6000
12,5	398	2,6	74,18	S083	80B	6	18000	7200
12,5	381	3,1	224,76	S103	71B	2	22000	9000
12,4	383	2,0	226,04	S083	71B	2	18000	7200
11,7	422	2,4	117,17	S083	71C/80A	4	18000	7200
11,4	437	1,4	81,43	S063	80B	6	10000	4000
11,4	438	2,4	81,71	S083	80B	6	18000	7200
11,4	436	3,8	81,39	S103	80B	6	22000	9000
11,3	437	3,7	121,29	S103	71C/80A	4	22000	9000
11,2	425	1,8	250,50	S083	71B	2	18000	7200
10,8	456	1,3	126,43	S063	71C/80A	4	10000	4000
10,6	464	2,2	128,73	S083	71C/80A	4	18000	7200
10,6	451	1,7	266,13	S083	71B	2	18000	7200
10,6	464	3,4	128,73	S103	71C/80A	4	22000	9000
10,4	481	3,5	89,77	S103	80B	6	22000	9000
10,2	491	2,1	91,49	S083	80B	6	18000	7200
10,2	465	2,6	274,20	S103	71B	2	22000	9000
10,0	491	2,0	136,34	S083	71C/80A	4	18000	7200
10,0	476	2,5	280,89	S103	71B	2	22000	9000
9,7	509	3,1	141,24	S103	71C/80A	4	22000	9000
9,6	496	1,5	292,36	S083	71B	2	18000	7200
9,6	496	2,4	292,36	S103	71B	2	22000	9000
9,3	536	1,2	99,89	S063	80B	6	10000	4000
9,3	537	3,1	100,15	S103	80B	6	22000	9000
9,2	540	1,9	100,62	S083	80B	6	18000	7200
9,1	544	1,1	150,85	S063	71C/80A	4	10000	4000
8,9	535	1,4	315,73	S083	71B	2	18000	7200
8,8	544	2,2	320,79	S103	71B	2	22000	9000
8,6	572	1,7	158,76	S083	71C/80A	4	18000	7200
8,4	593	2,8	110,55	S103	80B	6	22000	9000
8,1	586	2,0	345,60	S103	71B	2	22000	9000
7,9	628	1,7	117,17	S083	80B	6	18000	7200
7,9	626	2,6	173,78	S103	71C/80A	4	22000	9000

0,55 kW

n2 [rpm]	M2 [Nm]	fs	i	Gear reducer	Motor Size	Pole	Fr2 D [N]	Fr2 C-L [N]
7,8	611	1,2	360,58	S083	71B	2	18000	7200
7,7	650	2,6	121,29	S103	80B	6	22000	9000
7,6	653	0,9	185,05	S063	80A	4	10000	4000
7,5	658	0,9	182,53	S063	71C/80A	4	10000	4000
7,4	678	0,9	126,43	S063	80B	6	10000	4000
7,4	666	1,5	184,88	S083	71C/80A	4	18000	7200
7,3	679	2,4	188,51	S103	71C/80A	4	22000	9000
7,2	690	1,5	128,73	S083	80B	6	18000	7200
7,2	690	2,4	128,73	S103	80B	6	22000	9000
7,1	669	1,8	394,69	S103	71B	2	22000	9000
6,8	731	1,4	136,34	S083	80B	6	18000	7200
6,7	732	1,4	203,11	S083	71C/80A	4	18000	7200
6,7	740	1,4	205,34	S083	71C/80A	4	18000	7200
6,7	732	2,2	203,11	S103	71C/80A	4	22000	9000
6,6	757	2,2	141,24	S103	80B	6	22000	9000
6,5	760	3,9	215,60	S123	80A	4	30000	11200
6,1	815	1,2	226,04	S083	71C/80A	4	18000	7200
6,1	803	2,0	222,85	S103	71C/80A	4	22000	9000
6,1	810	2,0	224,76	S103	71C/80A	4	22000	9000
6,1	812	3,9	151,43	S123	80B	6	30000	11200
5,9	851	1,2	158,76	S083	80B	6	18000	7200
5,9	843	3,6	238,93	S123	80A	4	30000	11200
5,5	903	1,1	250,50	S083	71C/80A	4	18000	7200
5,5	901	3,3	255,54	S123	80A	4	30000	11200
5,4	932	1,8	173,78	S103	80B	6	22000	9000
5,2	952	3,3	177,53	S123	80B	6	30000	11200
5,1	959	1,0	266,13	S083	71C/80A	4	18000	7200
5,0	991	1,1	184,88	S083	80B	6	18000	7200
5,0	988	1,6	274,20	S103	71C/80A	4	22000	9000
5,0	988	3,0	280,10	S123	80A	4	30000	11200
4,9	1011	1,7	188,51	S103	80B	6	22000	9000
4,9	1012	1,6	280,89	S103	71C/80A	4	22000	9000
4,8	1043	3,0	194,59	S123	80B	6	30000	11200
4,7	1054	0,9	292,36	S083	71C/80A	4	18000	7200
4,7	1054	1,5	292,36	S103	71C/80A	4	22000	9000
4,6	1089	1,0	203,11	S083	80B	6	18000	7200
4,6	1089	1,5	203,11	S103	80B	6	22000	9000
4,6	1062	2,8	301,16	S123	80A	4	30000	11200
4,5	1101	1,0	205,34	S083	80B	6	18000	7200
4,3	1156	1,4	320,79	S103	71C/80A	4	22000	9000
4,3	1156	2,7	215,60	S123	80B	6	30000	11200
4,2	1195	1,4	222,85	S103	80B	6	22000	9000

0,55 kW

n2 [rpm]	M2 [Nm]	fs	i	Gear reducer	Size	Motor Pole	Fr2 D [N]	Fr2 C-L [N]
4,1	1205	1,4	224,76	S103	80B	6	22000	9000
4,1	1213	2,5	343,93	S123	80A	4	30000	11200
4,0	1246	1,3	345,60	S103	71C/80A	4	22000	9000
3,9	1281	2,5	238,93	S123	80B	6	30000	11200
3,6	1370	2,3	255,54	S123	80B	6	30000	11200
3,5	1422	1,1	394,69	S103	71C/80A	4	22000	9000
3,4	1470	1,1	274,20	S103	80B	6	22000	9000
3,3	1506	1,1	280,89	S103	80B	6	22000	9000
3,3	1502	2,1	280,10	S123	80B	6	30000	11200
3,2	1568	1,1	292,36	S103	80B	6	22000	9000
3,1	1615	2,0	301,16	S123	80B	6	30000	11200
2,9	1720	1,0	320,79	S103	80B	6	22000	9000
2,7	1853	0,9	345,60	S103	80B	6	22000	9000
2,7	1844	1,7	343,93	S123	80B	6	30000	11200

0,75 kW

n2 [rpm]	M2 [Nm]	fs	i	Gear reducer	Size	Motor Pole	Fr2 D [N]	Fr2 C-L [N]
141,9	47	3,9	19,73	S052	71C/80A	2	4289	4289
133,1	50	3,9	21,04	S052	71C/80A	2	4369	4369
130,1	51	3,8	21,53	S052	71C/80A	2	4398	4398
125,7	55	3,5	11,14	S052	80B	4	4430	4430
116,7	59	3,4	12,00	S052	80B	4	4523	4523
116,3	57	3,4	24,07	S052	71C/80A	2	4538	4538
111,1	60	3,6	25,20	S052	71C/80A	2	4597	4597
108,6	61	3,6	25,79	S052	71C/80A	2	4627	4627
106,7	65	2,7	8,63	S052	80C/90S	6	4633	4633
102,5	67	3,1	13,66	S052	80B	4	4688	4688
100,7	66	3,3	27,81	S052	71C/80A	2	4725	4725
93,3	71	3,1	30,00	S052	71C/80A	2	4824	4824
91,7	75	3,2	15,27	S052	80B	4	4833	4833
86,0	80	3,0	16,29	S052	80B	4	4916	4916
86,0	77	2,9	32,55	S052	71C/80A	2	4932	4932
84,8	78	2,9	33,00	S052	71C/80A	2	4950	4950
82,6	84	2,4	11,14	S052	80C/90S	6	4964	4964
82,1	81	2,8	34,09	S052	71C/80A	2	4993	4993
76,7	91	2,3	12,00	S052	80C/90S	6	5062	5062
76,7	85	3,1	36,50	S053	71C/80A	2	5095	5095
76,6	87	2,9	36,55	S052	71C/80A	2	5086	5086
75,1	92	2,6	18,63	S052	80B	4	5094	5094
72,3	92	2,7	38,75	S052	71C/80A	2	5165	5165
71,0	97	2,5	19,73	S052	80B	4	5170	5170

0,75 kW

n2 [rpm]	M2 [Nm]	fs	i	Gear reducer	Motor Size	Pole	Fr2 D [N]	Fr2 C-L [N]
70,2	95	2,8	39,90	S052	71C/80A	2	5205	5205
67,4	103	2,1	13,66	S052	80C/90S	6	5233	5233
66,6	103	2,5	21,04	S052	80B	4	5255	5255
65,7	101	2,6	42,63	S052	71C/80A	2	5294	5294
65,0	106	2,5	21,53	S052	80B	4	5286	5286
60,9	109	2,4	46,00	S052	71C/80A	2	5397	5397
60,2	115	2,2	15,27	S052	80C/90S	6	5381	5381
59,4	109	2,4	47,14	S053	71C/80A	2	5444	5444
59,3	112	2,3	47,20	S052	71C/80A	2	5432	5432
58,2	118	2,2	24,07	S052	80B	4	5435	5435
58,0	114	3,9	48,30	S062	71C/80A	2	9811	3924
57,7	120	3,9	15,94	S062	80C/90S	6	9788	3915
57,0	114	3,9	49,13	S063	71C/80A	2	9873	3949
56,9	122	3,9	16,16	S062	80C/90S	6	9827	3931
56,5	123	2,0	16,29	S052	80C/90S	6	5467	5467
55,7	123	3,9	25,14	S062	80B	4	9895	3958
55,6	124	2,3	25,20	S052	80B	4	5496	5496
54,3	127	2,3	25,79	S052	80B	4	5527	5527
53,6	124	2,1	52,25	S052	71C/80A	2	5570	5570
52,3	127	3,5	53,53	S062	71C/80A	2	10000	4000
50,9	130	3,5	55,00	S062	71C/80A	2	10000	4000
50,6	136	3,5	27,66	S062	80B	4	10000	4000
50,6	128	3,5	55,29	S063	71C/80A	2	10000	4000
50,3	137	2,1	27,81	S052	80B	4	5627	5627
49,4	141	1,8	18,63	S052	80C/90S	6	5644	5644
48,5	134	2,0	57,79	S053	71C/80A	2	5723	5723
48,4	137	1,9	57,86	S052	71C/80A	2	5708	5708
47,7	146	3,2	19,29	S062	80C/90S	6	10000	4000
47,7	136	3,3	58,72	S063	71C/80A	2	10000	4000
47,1	141	1,9	59,42	S052	71C/80A	2	5744	5744
47,1	148	3,3	19,55	S062	80C/90S	6	10000	4000
46,7	147	2,0	30,00	S052	80B	4	5727	5727
46,7	147	3,4	30,00	S062	80B	4	10000	4000
46,6	149	1,7	19,73	S052	80C/90S	6	5719	5719
43,9	148	1,8	63,74	S053	71C/80A	2	5857	5857
43,7	159	1,7	21,04	S052	80C/90S	6	5803	5803
43,0	160	1,9	32,55	S052	80B	4	5834	5834
42,7	163	1,7	21,53	S052	80C/90S	6	5833	5833
42,5	153	2,9	65,85	S063	71C/80A	2	10000	4000
42,4	162	1,9	33,00	S052	80B	4	5852	5852
41,7	161	3,7	33,57	S063	80B	4	10000	4000
41,5	160	2,8	67,47	S062	71C/80A	2	10000	4000

0,75 kW

n2 [rpm]	M2 [Nm]	fs	i	Gear reducer	Motor Size	Pole	Fr2 D [N]	Fr2 C-L [N]
41,3	167	3,2	33,93	S062	80B	4	10000	4000
41,1	167	1,8	34,09	S052	80B	4	5894	5894
41,0	158	2,8	68,25	S063	71C/80A	2	10000	4000
39,7	175	2,8	23,18	S062	80C/90S	6	10000	4000
38,7	179	2,8	23,75	S062	80C/90S	6	10000	4000
38,4	173	1,5	72,83	S052	71C/80A	2	6000	6000
38,4	176	2,0	36,50	S053	80B	4	6000	6000
38,3	179	1,8	36,55	S052	80B	4	5983	5983
38,3	180	3,3	36,57	S062	80B	4	10000	4000
38,2	182	1,5	24,07	S052	80C/90S	6	5976	5976
38,0	171	2,6	73,63	S063	71C/80A	2	10000	4000
37,7	172	1,5	74,20	S053	71C/80A	2	6000	6000
37,1	182	3,3	37,77	S063	80B	4	10000	4000
36,6	190	2,7	25,14	S062	80C/90S	6	10000	4000
36,5	190	1,6	25,20	S052	80C/90S	6	6000	6000
36,1	190	1,7	38,75	S052	80B	4	6000	6000
35,8	181	1,4	78,14	S053	71C/80A	2	6000	6000
35,7	195	1,6	25,79	S052	80C/90S	6	6000	6000
35,6	193	3,1	39,38	S062	80B	4	10000	4000
35,1	196	1,8	39,90	S052	80B	4	6000	6000
35,0	193	3,1	40,05	S063	80B	4	10000	4000
34,4	189	2,4	81,43	S063	71C/80A	2	10000	4000
34,4	189	4,0	81,71	S083	80A ⁽¹⁾	2	18000	6781
33,3	209	2,4	27,66	S062	80C/90S	6	10000	4000
33,1	210	1,5	27,81	S052	80C/90S	6	6000	6000
32,8	209	1,7	42,63	S052	80B	4	6000	6000
32,1	214	2,8	43,64	S062	80B	4	10000	4000
30,7	226	1,3	30,00	S052	80C/90S	6	6000	6000
30,7	226	2,3	30,00	S062	80C/90S	6	10000	4000
30,7	212	3,5	91,49	S083	80A	2	18000	7025
30,4	226	1,5	46,00	S052	80B	4	6000	6000
30,4	226	2,7	46,10	S062	80B	4	10000	4000
29,7	232	1,5	47,20	S052	80B	4	6000	6000
29,7	227	1,5	47,14	S053	80B	4	6000	6000
29,2	222	1,2	95,84	S053	71C/80A	2	6000	6000
29,0	237	2,5	48,30	S062	80B	4	10000	4000
28,5	236	2,5	49,13	S063	80B	4	10000	4000
28,3	246	1,3	32,55	S052	80C/90S	6	6000	6000
28,0	232	1,9	99,89	S063	71C/80A	2	10000	4000
27,9	249	1,3	33,00	S052	80C/90S	6	6000	6000
27,9	233	3,2	100,62	S083	80A	2	18000	7200
27,4	248	2,5	33,57	S063	80C/90S	6	10000	4000

⁽¹⁾ Available only with brake motor (TBS)

0,75 kW

n2 [rpm]	M2 [Nm]	fs	i	Gear reducer	Motor Size	Pole	Fr2 D [N]	Fr2 C-L [N]
27,1	256	2,2	33,93	S062	80C/90S	6	10000	4000
27,0	257	1,2	34,09	S052	80C/90S	6	6000	6000
26,8	257	1,4	52,25	S052	80B	4	6000	6000
26,4	264	4,0	34,91	S082	80C/90S	6	18000	7200
26,2	263	2,3	53,53	S062	80B	4	10000	4000
25,9	268	3,9	35,50	S082	80C/90S	6	18000	7200
25,8	267	3,8	54,27	S082	80B	4	18000	7200
25,5	270	2,2	55,00	S062	80B	4	10000	4000
25,3	266	2,3	55,29	S063	80B	4	10000	4000
25,2	276	1,3	36,55	S052	80C/90S	6	6000	6000
25,2	270	1,4	36,50	S053	80C/90S	6	6000	6000
25,2	276	2,3	36,57	S062	80C/90S	6	10000	4000
24,4	279	2,3	37,77	S063	80C/90S	6	10000	4000
24,2	284	1,2	57,86	S052	80B	4	6000	6000
24,2	278	1,3	57,79	S053	80B	4	6000	6000
23,9	272	2,8	117,17	S083	71C/80A	2	18000	7200
23,8	282	2,1	58,72	S063	80B	4	10000	4000
23,7	293	1,2	38,75	S052	80C/90S	6	6000	6000
23,6	292	1,2	59,42	S052	80B	4	6000	6000
23,4	297	2,1	39,38	S062	80C/90S	6	10000	4000
23,1	301	1,2	39,90	S052	80C/90S	6	6000	6000
23,0	296	2,1	40,05	S063	80C/90S	6	10000	4000
23,0	302	3,5	40,05	S082	80C/90S	6	18000	7200
22,6	304	3,3	61,98	S082	80B	4	18000	7200
22,1	293	1,5	126,43	S063	71C/80A	2	10000	4000
22,0	307	1,1	63,74	S053	80B	4	6000	6000
21,8	299	2,5	128,73	S083	71C/80A	2	18000	7200
21,6	322	1,1	42,63	S052	80C/90S	6	6000	6000
21,4	325	3,2	43,05	S082	80C/90S	6	18000	7200
21,3	317	1,9	65,85	S063	80B	4	10000	4000
21,1	329	1,9	43,64	S062	80C/90S	6	10000	4000
20,8	331	1,8	67,47	S062	80B	4	10000	4000
20,7	325	3,1	67,52	S083	80B	4	18000	7200
20,5	328	1,8	68,25	S063	80B	4	10000	4000
20,5	316	2,4	136,34	S083	71C/80A	2	18000	7200
20,0	347	1,1	46,00	S052	80C/90S	6	6000	6000
20,0	348	1,8	46,10	S062	80C/90S	6	10000	4000
19,8	328	3,7	141,24	S103	71C/80A	2	22000	9000
19,5	356	1,0	47,20	S052	80C/90S	6	6000	6000
19,5	348	1,1	47,14	S053	80C/90S	6	6000	6000
19,2	358	1,0	72,83	S052	80B	4	6000	6000
19,0	365	1,7	48,30	S062	80C/90S	6	10000	4000

0,75 kW

n2 [rpm]	M2 [Nm]	fs	i	Gear reducer	Motor Size	Pole	Fr2 D [N]	Fr2 C-L [N]
19,0	354	1,7	73,63	S063	80B	4	10000	4000
18,9	357	1,0	74,20	S053	80B	4	6000	6000
18,9	357	2,8	74,18	S083	80B	4	18000	7200
18,7	363	1,7	49,13	S063	80C/90S	6	10000	4000
18,6	350	1,3	150,85	S063	71C/80A	2	10000	4000
18,3	379	2,8	50,25	S082	80C/90S	6	18000	7200
18,3	379	3,9	50,25	S102	80C/90S	6	22000	9000
17,9	376	0,9	78,14	S053	80B	4	6000	6000
17,6	394	0,9	52,25	S052	80C/90S	6	6000	6000
17,6	368	2,0	158,76	S083	71C/80A	2	18000	7200
17,2	404	1,6	53,53	S062	80C/90S	6	10000	4000
17,2	392	1,5	81,43	S063	80B	4	10000	4000
17,1	393	2,5	81,71	S083	80B	4	18000	7200
17,0	410	2,6	54,27	S082	80C/90S	6	18000	7200
16,7	415	1,5	55,00	S062	80C/90S	6	10000	4000
16,7	416	3,3	55,14	S102	80C/90S	6	22000	9000
16,6	409	1,5	55,29	S063	80C/90S	6	10000	4000
16,1	403	3,0	173,78	S103	71C/80A	2	22000	9000
15,7	434	1,5	58,72	S063	80C/90S	6	10000	4000
15,6	432	3,7	89,77	S103	80B	4	22000	9000
15,5	448	3,7	59,40	S102	80C/90S	6	22000	9000
15,3	424	1,1	182,53	S063	71C/80A	2	10000	4000
15,3	440	2,3	91,49	S083	80B	4	18000	7200
15,1	429	1,0	185,05	S063	71C/80A	2	10000	4000
15,1	429	1,7	184,88	S083	71C/80A	2	18000	7200
14,9	437	2,7	188,51	S103	71C/80A	2	22000	9000
14,8	468	2,2	61,98	S082	80C/90S	6	18000	7200
14,0	487	1,3	65,85	S063	80C/90S	6	10000	4000
14,0	480	1,2	99,89	S063	80B	4	10000	4000
14,0	482	3,3	100,15	S103	80B	4	22000	9000
13,9	484	2,1	100,62	S083	80B	4	18000	7200
13,8	471	1,6	203,11	S083	71C/80A	2	18000	7200
13,8	471	2,5	203,11	S103	71C/80A	2	22000	9000
13,6	509	1,2	67,47	S062	80C/90S	6	10000	4000
13,6	476	1,6	205,34	S083	71C/80A	2	18000	7200
13,6	499	2,1	67,52	S083	80C/90S	6	18000	7200
13,6	512	3,3	67,84	S102	80C/90S	6	22000	9000
13,5	504	1,2	68,25	S063	80C/90S	6	10000	4000
12,7	532	3,0	110,55	S103	80B	4	22000	9000
12,6	517	2,3	222,85	S103	71C/80A	2	22000	9000
12,5	544	1,2	73,63	S063	80C/90S	6	10000	4000
12,5	522	2,3	224,76	S103	71C/80A	2	22000	9000

0,75 kW

n2 [rpm]	M2 [Nm]	fs	i	Gear reducer	Motor Size	Pole	Fr2 D [N]	Fr2 C-L [N]
12,4	548	1,9	74,18	S083	80C/90S	6	18000	7200
12,4	524	1,4	226,04	S083	71C/80A	2	18000	7200
12,4	548	3,1	74,18	S103	80C/90S	6	22000	9000
11,9	564	1,8	117,17	S083	80B	4	18000	7200
11,5	583	2,7	121,29	S103	80B	4	22000	9000
11,3	602	1,0	81,43	S063	80C/90S	6	10000	4000
11,3	604	1,7	81,71	S083	80C/90S	6	18000	7200
11,3	602	2,8	81,39	S103	80C/90S	6	22000	9000
11,2	581	1,3	250,50	S083	71C/80A	2	18000	7200
11,1	608	1,0	126,43	S063	80B	4	10000	4000
11,0	591	3,8	255,54	S123	80A	2	30000	11200
10,9	619	1,6	128,73	S083	80B	4	18000	7200
10,9	619	2,6	128,73	S103	80B	4	22000	9000
10,5	618	1,2	266,13	S083	71C/80A	2	18000	7200
10,3	656	1,5	136,34	S083	80B	4	18000	7200
10,2	663	2,5	89,77	S103	80C/90S	6	22000	9000
10,2	636	1,9	274,20	S103	71C/80A	2	22000	9000
10,1	676	1,6	91,49	S083	80C/90S	6	18000	7200
10,0	652	1,8	280,89	S103	71C/80A	2	22000	9000
10,0	648	3,5	280,10	S123	80A	2	30000	11200
9,9	679	2,4	141,24	S103	80B	4	22000	9000
9,6	678	1,1	292,36	S083	71C/80A	2	18000	7200
9,6	678	1,8	292,36	S103	71C/80A	2	22000	9000
9,3	696	3,2	301,16	S123	80A	2	30000	11200
9,2	740	2,3	100,15	S103	80C/90S	6	22000	9000
9,1	744	1,4	100,62	S083	80C/90S	6	18000	7200
8,9	733	1,0	315,73	S083	71C/80A	2	18000	7200
8,8	764	1,3	158,76	S083	80B	4	18000	7200
8,7	744	1,6	320,79	S103	71C/80A	2	22000	9000
8,3	817	2,1	110,55	S103	80C/90S	6	22000	9000
8,2	832	3,8	112,52	S123	80C/90S	6	30000	11200
8,2	795	2,8	343,93	S123	80A	2	30000	11200
8,1	802	1,5	345,60	S103	71C/80A	2	22000	9000
8,1	836	1,9	173,78	S103	80B	4	22000	9000
7,9	866	1,2	117,17	S083	80C/90S	6	18000	7200
7,9	854	3,5	177,53	S123	80B	4	30000	11200
7,6	889	1,1	184,88	S083	80B	4	18000	7200
7,6	897	1,9	121,29	S103	80C/90S	6	22000	9000
7,5	912	3,5	123,33	S123	80C/90S	6	30000	11200
7,4	907	1,8	188,51	S103	80B	4	22000	9000
7,2	936	3,2	194,59	S123	80B	4	30000	11200
7,1	951	1,1	128,73	S083	80C/90S	6	18000	7200

0,75 kW

n2 [rpm]	M2 [Nm]	fs	i	Gear reducer	Motor Size	Pole	Fr2 D [N]	Fr2 C-L [N]
7,1	951	1,8	128,73	S103	80C/90S	6	22000	9000
7,1	916	1,3	394,69	S103	71C/80A	2	22000	9000
7,1	961	3,3	130,04	S123	80C/90S	6	30000	11200
6,9	977	1,0	203,11	S083	80B	4	18000	7200
6,9	977	1,6	203,11	S103	80B	4	22000	9000
6,9	989	3,2	133,78	S123	80C/90S	6	30000	11200
6,8	987	1,0	205,34	S083	80B	4	18000	7200
6,7	1008	1,0	136,34	S083	80C/90S	6	18000	7200
6,5	1044	1,6	141,24	S103	80C/90S	6	22000	9000
6,5	1037	2,9	215,60	S123	80B	4	30000	11200
6,3	1072	1,5	222,85	S103	80B	4	22000	9000
6,2	1087	0,9	226,04	S083	80B	4	18000	7200
6,2	1081	1,5	224,76	S103	80B	4	22000	9000
6,1	1119	2,8	151,43	S123	80C/90S	6	30000	11200
5,9	1149	0,9	158,76	S083	90S	6	18000	7200
5,9	1149	2,6	238,93	S123	80B	4	30000	11200
5,5	1229	2,4	255,54	S123	80B	4	30000	11200
5,3	1284	1,3	173,78	S103	80C/90S	6	22000	9000
5,2	1312	2,4	177,53	S123	80C/90S	6	30000	11200
5,1	1319	1,2	274,20	S103	80B	4	22000	9000
5,0	1351	1,2	280,89	S103	80B	4	22000	9000
5,0	1347	2,2	280,10	S123	80B	4	30000	11200
4,9	1393	1,2	188,51	S103	80C/90S	6	22000	9000
4,8	1406	1,1	292,36	S103	80B	4	22000	9000
4,7	1438	2,2	194,59	S123	80C/90S	6	30000	11200
4,6	1448	2,1	301,16	S123	80B	4	30000	11200
4,5	1501	1,1	203,11	S103	80C/90S	6	22000	9000
4,4	1543	1,0	320,79	S103	80B	4	22000	9000
4,3	1594	2,0	215,60	S123	80C/90S	6	30000	11200
4,1	1662	1,0	345,60	S103	80B	4	22000	9000
4,1	1647	1,0	222,85	S103	80C/90S	6	22000	9000
4,1	1661	1,0	224,76	S103	80C/90S	6	22000	9000
4,1	1654	1,8	343,93	S123	80B	4	30000	11200
3,9	1766	1,8	238,93	S123	80C/90S	6	30000	11200
3,6	1889	1,7	255,54	S123	80C/90S	6	30000	11200
3,3	2070	1,5	280,10	S123	80C/90S	6	30000	11200
3,1	2226	1,4	301,16	S123	80C/90S	6	30000	11200
2,7	2542	1,2	343,93	S123	80C/90S	6	30000	11200

0,92 kW

n2 [rpm]	M2 [Nm]	fs	i	Gear reducer	Size	Motor Pole	Fr2 D [N]	Fr2 C-L [N]
162,3	52	3,3	8,63	S052	80C ⁽¹⁾	4	4061	4061
125,7	67	2,8	11,14	S052	80C ⁽¹⁾	4	4358	4358
116,7	72	2,8	12,00	S052	80C ⁽¹⁾	4	4445	4445
102,5	82	2,6	13,66	S052	80C ⁽¹⁾	4	4599	4599
91,7	92	2,6	15,27	S052	80C ⁽¹⁾	4	4734	4734
86,0	98	2,4	16,29	S052	80C ⁽¹⁾	4	4811	4811
75,1	112	2,1	18,63	S052	80C ⁽¹⁾	4	4973	4973
72,6	116	3,9	19,29	S062	80C ⁽¹⁾	4	9046	3618
71,6	118	3,9	19,55	S062	80C ⁽¹⁾	4	9080	3632
71,0	119	2,0	19,73	S052	80C ⁽¹⁾	4	5042	5042
66,6	127	2,1	21,04	S052	80C ⁽¹⁾	4	5119	5119
65,0	130	2,0	21,53	S052	80C ⁽¹⁾	4	5147	5147
60,4	140	3,4	23,18	S062	80C ⁽¹⁾	4	9509	3804
58,9	143	3,3	23,75	S062	80C ⁽¹⁾	4	9571	3829
58,2	145	1,8	24,07	S052	80C ⁽¹⁾	4	5279	5279
55,7	151	3,2	25,14	S062	80C ⁽¹⁾	4	9717	3887
55,6	152	1,9	25,20	S052	80C ⁽¹⁾	4	5333	5333
54,3	155	1,9	25,79	S052	80C ⁽¹⁾	4	5360	5360
50,6	167	2,9	27,66	S062	80C ⁽¹⁾	4	9962	3985
50,3	168	1,7	27,81	S052	80C ⁽¹⁾	4	5447	5447
46,7	181	1,6	30,00	S052	80C ⁽¹⁾	4	5533	5533
46,7	181	2,8	30,00	S062	80C ⁽¹⁾	4	10000	4000
43,0	196	1,5	32,55	S052	80C ⁽¹⁾	4	5624	5624
42,4	199	1,5	33,00	S052	80C ⁽¹⁾	4	5638	5638
41,7	198	3,0	33,57	S063	80C ⁽¹⁾	4	10000	4000
41,3	204	2,6	33,93	S062	80C ⁽¹⁾	4	10000	4000
41,1	205	1,5	34,09	S052	80C ⁽¹⁾	4	5674	5674
38,4	215	1,6	36,50	S053	80C ⁽¹⁾	4	5772	5772
38,3	220	1,5	36,55	S052	80C ⁽¹⁾	4	5747	5747
38,3	220	2,7	36,57	S062	80C ⁽¹⁾	4	10000	4000
37,1	223	2,7	37,77	S063	80C ⁽¹⁾	4	10000	4000
36,1	233	1,4	38,75	S052	80C ⁽¹⁾	4	5807	5807
35,6	237	2,5	39,38	S062	80C ⁽¹⁾	4	10000	4000
35,1	240	1,5	39,90	S052	80C ⁽¹⁾	4	5836	5836
35,0	236	2,5	40,05	S063	80C ⁽¹⁾	4	10000	4000
32,8	257	1,4	42,63	S052	80C ⁽¹⁾	4	5900	5900
32,5	259	3,9	43,05	S082	80C ⁽¹⁾	4	18000	6845
32,1	263	2,3	43,64	S062	80C ⁽¹⁾	4	10000	4000
30,4	277	1,3	46,00	S052	80C ⁽¹⁾	4	5970	5970
30,4	278	2,2	46,10	S062	80C ⁽¹⁾	4	10000	4000
29,7	284	1,2	47,20	S052	80C ⁽¹⁾	4	5993	5993
29,7	278	1,3	47,14	S053	80C ⁽¹⁾	4	6000	6000

⁽¹⁾ Available only with brake motor (TBS)

0,92 kW

n2 [rpm]	M2 [Nm]	fs	i	Gear reducer	Size	Motor Pole	Fr2 D [N]	Fr2 C-L [N]
29,0	291	2,1	48,30	S062	80C ⁽¹⁾	4	10000	4000
28,5	290	2,1	49,13	S063	80C ⁽¹⁾	4	10000	4000
27,9	303	3,3	50,25	S082	80C ⁽¹⁾	4	18000	7175
26,8	315	1,1	52,25	S052	80C ⁽¹⁾	4	6000	6000
26,2	322	1,9	53,53	S062	80C ⁽¹⁾	4	10000	4000
25,8	327	3,1	54,27	S082	80C ⁽¹⁾	4	18000	7200
25,5	331	1,8	55,00	S062	80C ⁽¹⁾	4	10000	4000
25,4	332	3,9	55,14	S102	80C ⁽¹⁾	4	22000	9000
25,3	326	1,8	55,29	S063	80C ⁽¹⁾	4	10000	4000
24,2	349	1,0	57,86	S052	80C ⁽¹⁾	4	6000	6000
24,2	341	1,0	57,79	S053	80C ⁽¹⁾	4	6000	6000
23,8	346	1,7	58,72	S063	80C ⁽¹⁾	4	10000	4000
23,6	358	1,0	59,42	S052	80C ⁽¹⁾	4	6000	6000
22,6	373	2,7	61,98	S082	80C ⁽¹⁾	4	18000	7200
22,0	376	0,9	63,74	S053	80C ⁽¹⁾	4	6000	6000
21,3	388	1,5	65,85	S063	80C ⁽¹⁾	4	10000	4000
20,8	406	1,5	67,47	S062	80C ⁽¹⁾	4	10000	4000
20,7	398	2,5	67,52	S083	80C ⁽¹⁾	4	18000	7200
20,6	409	3,9	67,84	S102	80C ⁽¹⁾	4	22000	9000
20,5	403	1,5	68,25	S063	80C ⁽¹⁾	4	10000	4000
19,0	434	1,4	73,63	S063	80C ⁽¹⁾	4	10000	4000
18,9	438	2,3	74,18	S083	80C ⁽¹⁾	4	18000	7200
18,9	438	3,7	74,18	S103	80C ⁽¹⁾	4	22000	9000
17,2	480	1,2	81,43	S063	80C ⁽¹⁾	4	10000	4000
17,2	480	3,3	81,39	S103	80C ⁽¹⁾	4	22000	9000
17,1	482	2,1	81,71	S083	80C ⁽¹⁾	4	18000	7200
15,6	530	3,0	89,77	S103	80C ⁽¹⁾	4	22000	9000
15,3	540	1,9	91,49	S083	80C ⁽¹⁾	4	18000	7200
14,0	589	1,0	99,89	S063	80C ⁽¹⁾	4	10000	4000
14,0	591	2,7	100,15	S103	80C ⁽¹⁾	4	22000	9000
13,9	594	1,7	100,62	S083	80C ⁽¹⁾	4	18000	7200
12,7	652	2,5	110,55	S103	80C ⁽¹⁾	4	22000	9000
11,9	691	1,4	117,17	S083	80C ⁽¹⁾	4	18000	7200
11,5	716	2,2	121,29	S103	80C ⁽¹⁾	4	22000	9000
10,9	759	1,3	128,73	S083	80C ⁽¹⁾	4	18000	7200
10,9	759	2,1	128,73	S103	80C ⁽¹⁾	4	22000	9000
10,8	767	3,9	130,04	S123	80C ⁽¹⁾	4	30000	11200
10,5	789	3,8	133,78	S123	80C ⁽¹⁾	4	30000	11200
10,3	804	1,2	136,34	S083	80C ⁽¹⁾	4	18000	7200
9,9	833	1,9	141,24	S103	80C ⁽¹⁾	4	22000	9000
9,2	893	3,4	151,43	S123	80C ⁽¹⁾	4	30000	11200
8,8	937	1,1	158,76	S083	80C ⁽¹⁾	4	18000	7200

⁽¹⁾ Available only with brake motor (TBS)

0,92 kW

n2 [rpm]	M2 [Nm]	fs	i	Gear reducer	Size	Motor Pole	Fr2 D [N]	Fr2 C-L [N]
8,1	1025	1,6	173,78	S103	80C ⁽¹⁾	4	22000	9000
7,9	1047	2,9	177,53	S123	80C ⁽¹⁾	4	30000	11200
7,6	1091	0,9	184,88	S083	80C ⁽¹⁾	4	18000	7200
7,4	1112	1,4	188,51	S103	80C ⁽¹⁾	4	22000	9000
7,2	1148	2,6	194,59	S123	80C ⁽¹⁾	4	30000	11200
6,9	1198	1,3	203,11	S103	80C ⁽¹⁾	4	22000	9000
6,5	1272	2,4	215,60	S123	80C ⁽¹⁾	4	30000	11200
6,3	1315	1,2	222,85	S103	80C ⁽¹⁾	4	22000	9000
6,2	1326	1,2	224,76	S103	80C ⁽¹⁾	4	22000	9000
5,9	1410	2,1	238,93	S123	80C ⁽¹⁾	4	30000	11200
5,5	1508	2,0	255,54	S123	80C ⁽¹⁾	4	30000	11200
5,1	1618	1,0	274,20	S103	80C ⁽¹⁾	4	22000	9000
5,0	1657	1,0	280,89	S103	80C ⁽¹⁾	4	22000	9000
5,0	1652	1,8	280,10	S123	80C ⁽¹⁾	4	30000	11200
4,8	1725	0,9	292,36	S103	80C ⁽¹⁾	4	22000	9000
4,6	1777	1,7	301,16	S123	80C ⁽¹⁾	4	30000	11200
4,1	2029	1,5	343,93	S123	80C ⁽¹⁾	4	30000	11200

1,10 kW

n2 [rpm]	M2 [Nm]	fs	i	Gear reducer	Size	Motor Pole	Fr2 D [N]	Fr2 C-L [N]
254,9	38	3,7	11,14	S052	80B	2	3537	3537
236,7	41	3,6	12,00	S052	80B	2	3614	3614
208,0	47	3,4	13,66	S052	80B	2	3749	3749
185,3	53	3,4	15,27	S052	80B	2	3871	3871
174,4	56	3,2	16,29	S052	80B	2	3937	3937
163,5	62	2,8	8,63	S052	80D/90S	4	3994	3994
152,4	64	2,8	18,63	S052	80B	2	4083	4083
144,0	68	2,7	19,73	S052	80B	2	4146	4146
135,0	72	2,7	21,04	S052	80B	2	4218	4218
131,9	74	2,6	21,53	S052	80B	2	4243	4243
126,6	80	2,4	11,14	S052	80D/90S	4	4273	4273
117,6	83	2,4	24,07	S052	80B	2	4372	4372
117,5	86	2,3	12,00	S052	80D/90S	4	4355	4355
116,3	88	4,0	8,00	S062	90L	6	7819	3128
112,3	87	2,5	25,20	S052	80B	2	4423	4423
109,8	89	2,5	25,79	S052	80B	2	4449	4449
107,8	94	1,9	8,63	S052	90L/100LR	6	4445	4445
104,2	98	3,5	8,92	S062	90L/100LR	6	8062	3225
103,2	98	2,2	13,66	S052	80D/90S	4	4498	4498
102,7	95	3,8	27,66	S062	80B	2	8124	3250
101,8	96	2,3	27,81	S052	80B	2	4534	4534

⁽¹⁾ Available only with brake motor (TBS)

1,10 kW

n2 [rpm]	M2 [Nm]	fs	i	Gear reducer	Motor Size	Pole	Fr2 D [N]	Fr2 C-L [N]
97,4	105	3,6	9,55	S062	90L/100LR	6	8215	3286
94,7	103	2,1	30,00	S052	80B	2	4615	4615
94,7	103	3,6	30,00	S062	80B	2	8310	3324
91,7	110	2,2	15,27	S052	80D/90S	4	4629	4629
87,8	115	3,9	15,94	S062	80D/90S	4	8458	3383
87,4	117	3,2	10,65	S062	90L/100LR	6	8464	3385
87,3	112	2,0	32,55	S052	80B	2	4707	4707
87,2	116	3,9	16,16	S062	80D/90S	4	8474	3390
86,1	113	2,0	33,00	S052	80B	2	4722	4722
86,0	117	2,0	16,29	S052	80D/90S	4	4700	4700
84,6	113	4,0	33,57	S063	80B	2	8587	3435
83,5	122	1,6	11,14	S052	90L/100LR	6	4725	4725
83,4	117	3,5	33,93	S062	80B	2	8604	3442
83,3	117	1,9	34,09	S052	80B	2	4759	4759
79,4	128	3,2	11,71	S062	90L/100LR	6	8684	3473
77,5	131	1,6	12,00	S052	90L/100LR	6	4805	4805
77,5	123	2,1	36,50	S053	80B	2	4854	4854
77,4	126	2,0	36,55	S052	80B	2	4840	4840
77,4	126	3,6	36,57	S062	80B	2	8781	3513
75,2	127	3,6	37,77	S063	80B	2	8867	3547
75,1	134	1,8	18,63	S052	80D/90S	4	4846	4846
73,3	133	1,9	38,75	S052	80B	2	4901	4901
72,6	139	3,2	19,29	S062	80D/90S	4	8902	3561
72,1	135	3,3	39,38	S062	80B	2	8948	3579
71,6	141	3,3	19,55	S062	80D/90S	4	8934	3574
71,2	137	1,9	39,90	S052	80B	2	4933	4933
71,2	143	3,1	13,06	S062	90L/100LR	6	8938	3575
71,0	142	1,7	19,73	S052	80D/90S	4	4907	4907
70,7	135	3,3	40,05	S063	80B	2	9015	3606
69,6	146	3,0	13,36	S062	90L/100LR	6	8991	3596
68,1	150	1,5	13,66	S052	90L/100LR	6	4942	4942
66,6	152	1,7	21,04	S052	80D/90S	4	4975	4975
66,4	147	1,8	42,63	S052	80B	2	5009	5009
65,1	150	3,0	43,64	S062	80B	2	9194	3677
65,0	155	1,7	21,53	S052	80D/90S	4	4999	4999
61,7	158	1,7	46,00	S052	80B	2	5087	5087
61,4	159	2,8	46,10	S062	80B	2	9334	3734
60,9	167	1,5	15,27	S052	90L/100LR	6	5058	5058
60,4	167	2,8	23,18	S062	80D/90S	4	9336	3734
60,2	162	1,6	47,20	S052	80B	2	5114	5114
60,0	159	1,7	47,14	S053	80B	2	5136	5136
58,9	171	2,7	23,75	S062	80D/90S	4	9394	3758

1,10 kW

n2 [rpm]	M2 [Nm]	fs	i	Gear reducer	Motor Size	Pole	Fr2 D [N]	Fr2 C-L [N]
58,8	166	2,7	48,30	S062	80B	2	9438	3775
58,4	175	2,7	15,94	S062	90L/100LR	6	9407	3763
58,2	173	1,5	24,07	S052	80D/90S	4	5114	5114
57,8	165	2,7	49,13	S063	80B	2	9501	3801
57,5	177	2,7	16,16	S062	90L/100LR	6	9440	3776
57,1	178	1,4	16,29	S052	90L/100LR	6	5123	5123
55,7	181	2,7	25,14	S062	80D/90S	4	9529	3812
55,6	182	1,6	25,20	S052	80D/90S	4	5160	5160
54,3	186	1,6	25,79	S052	80D/90S	4	5183	5183
54,2	180	1,5	52,25	S052	80B	2	5224	5224
52,9	184	2,4	53,53	S062	80B	2	9695	3878
51,5	189	2,4	55,00	S062	80B	2	9760	3904
51,2	186	2,4	55,29	S063	80B	2	9798	3919
50,6	199	2,4	27,66	S062	80D/90S	4	9756	3902
50,3	200	1,4	27,81	S052	80D/90S	4	5257	5257
49,9	204	1,2	18,63	S052	90L/100LR	6	5253	5253
49,0	195	1,3	57,79	S053	80B	2	5349	5349
48,9	199	1,3	57,86	S052	80B	2	5326	5326
48,9	208	3,9	19,03	S082	90L/100LR	6	18000	6001
48,2	211	2,2	19,29	S062	90L/100LR	6	9857	3943
48,2	198	2,3	58,72	S063	80B	2	9945	3978
47,8	204	1,3	59,42	S052	80B	2	5348	5348
47,6	214	2,3	19,55	S062	90L/100LR	6	9890	3956
47,1	216	1,2	19,73	S052	90L/100LR	6	5306	5306
46,7	216	1,3	30,00	S052	80D/90S	4	5328	5328
46,7	216	2,3	30,00	S062	80D/90S	4	9948	3979
46,2	221	3,7	20,14	S082	90L/100LR	6	18000	6107
45,7	213	3,5	61,98	S082	80B	2	18000	6137
44,4	215	1,2	63,74	S053	80B	2	5445	5445
44,2	230	1,2	21,04	S052	90L/100LR	6	5363	5363
43,2	236	1,2	21,53	S052	90L/100LR	6	5383	5383
43,0	234	1,3	32,55	S052	80D/90S	4	5401	5401
43,0	222	2,0	65,85	S063	80B	2	10000	4000
42,4	238	1,3	33,00	S052	80D/90S	4	5413	5413
42,1	227	3,3	67,52	S083	80B	2	18000	6299
42,0	242	3,5	22,13	S082	90L/100LR	6	18000	6285
41,9	232	1,9	67,47	S062	80B	2	10000	4000
41,7	237	2,5	33,57	S063	80D/90S	4	10000	4000
41,5	230	2,0	68,25	S063	80B	2	10000	4000
41,3	244	2,2	33,93	S062	80D/90S	4	10000	4000
41,1	246	1,2	34,09	S052	80D/90S	4	5440	5440
40,1	254	1,9	23,18	S062	90L/100LR	6	10000	4000

1,10 kW

n2 [rpm]	M2 [Nm]	fs	i	Gear reducer	Motor Size	Pole	Fr2 D [N]	Fr2 C-L [N]
40,1	251	4,0	34,91	S082	90S ⁽¹⁾	4	18000	6378
39,4	256	3,9	35,50	S082	80D/90S	4	18000	6411
39,2	260	1,9	23,75	S062	90L/100LR	6	10000	4000
39,0	250	1,1	72,83	S052	80B	2	5535	5535
38,8	263	3,2	24,00	S082	90L/100LR	6	18000	6443
38,6	264	1,0	24,07	S052	90L/100LR	6	5475	5475
38,4	257	1,4	36,50	S053	80D/90S	4	5528	5528
38,4	248	1,8	73,63	S063	80B	2	10000	4000
38,3	263	1,3	36,55	S052	80D/90S	4	5497	5497
38,3	263	2,3	36,57	S062	80D/90S	4	10000	4000
38,1	250	1,1	74,20	S053	80B	2	5585	5585
38,1	250	3,0	74,18	S083	80B	2	18000	6490
37,1	266	2,3	37,77	S063	80D/90S	4	10000	4000
37,0	275	1,8	25,14	S062	90L/100LR	6	10000	4000
36,9	276	1,1	25,20	S052	90L/100LR	6	5510	5510
36,3	262	1,0	78,14	S053	80B	2	5626	5626
36,1	282	1,1	25,79	S052	90L/100LR	6	5527	5527
36,1	279	1,2	38,75	S052	80D/90S	4	5542	5542
35,7	285	2,9	26,05	S082	90L/100LR	6	18000	6605
35,6	284	2,1	39,38	S062	80D/90S	4	10000	4000
35,1	287	1,2	39,90	S052	80D/90S	4	5563	5563
35,0	283	2,1	40,05	S063	80D/90S	4	10000	4000
35,0	289	3,5	40,05	S082	80D/90S	4	18000	6650
34,8	274	1,6	81,43	S063	80B	2	10000	4000
34,6	275	2,7	81,71	S083	80B	2	18000	6684
34,1	299	3,2	27,29	S082	90L/100LR	6	18000	6699
33,6	303	1,7	27,66	S062	90L/100LR	6	10000	4000
33,4	305	1,0	27,81	S052	90L/100LR	6	5579	5579
32,8	307	1,1	42,63	S052	80D/90S	4	5608	5608
32,5	310	3,2	43,05	S082	80D/90S	4	18000	6797
32,4	314	3,0	28,67	S082	90L/100LR	6	18000	6800
32,1	314	1,9	43,64	S062	80D/90S	4	10000	4000
31,5	302	4,0	89,77	S103	80B	2	22000	8490
31,4	324	2,9	29,60	S082	90L/100LR	6	18000	6865
31,0	329	0,9	30,00	S052	90L	6	5626	5626
31,0	329	1,6	30,00	S062	90L/100LR	6	10000	4000
30,9	308	2,4	91,49	S083	80B	2	18000	6917
30,4	331	1,1	46,00	S052	80D/90S	4	5655	5655
30,4	332	1,8	46,10	S062	80D/90S	4	10000	4000
29,7	340	1,0	47,20	S052	80D/90S	4	5670	5670
29,7	333	1,1	47,14	S053	80D/90S	4	5710	5710
29,3	348	3,0	31,78	S082	90L/100LR	6	18000	7012

⁽¹⁾ Available only with brake motor (TBS)

1,10 kW

n2 [rpm]	M2 [Nm]	fs	i	Gear reducer	Motor Size	Pole	Fr2 D [N]	Fr2 C-L [N]
29,2	349	0,9	32,55	S052	100LR	6	5659	5659
29,0	348	1,7	48,30	S062	80D/90S	4	10000	4000
28,5	347	1,7	49,13	S063	80D/90S	4	10000	4000
28,3	336	1,3	99,89	S063	80B	2	10000	4000
28,3	337	3,6	100,15	S103	80B	2	22000	8785
28,1	339	2,2	100,62	S083	80B	2	18000	7118
27,9	362	2,8	50,25	S082	80D/90S	4	18000	7120
27,9	362	3,9	50,25	S102	80D/90S	4	22000	8809
27,7	360	1,8	33,57	S063	90L	6	10000	4000
27,4	372	1,5	33,93	S062	90L/100LR	6	10000	4000
26,8	376	0,9	52,25	S052	80D/90S	4	5719	5719
26,6	382	2,7	34,91	S082	90L/100LR	6	18000	7200
26,6	382	3,8	34,91	S102	90L/100LR	6	22000	8929
26,2	386	1,6	53,53	S062	80D/90S	4	10000	4000
26,2	389	2,7	35,50	S082	90L/100LR	6	18000	7200
25,8	391	2,6	54,27	S082	80D/90S	4	18000	7200
25,6	372	3,2	110,55	S103	80B	2	22000	9000
25,5	391	0,9	36,50	S053	90L	6	5764	5764
25,5	396	1,5	55,00	S062	80D/90S	4	10000	4000
25,4	401	1,6	36,57	S062	90L/100LR	6	10000	4000
25,4	397	3,3	55,14	S102	80D/90S	4	22000	9000
25,3	390	1,5	55,29	S063	80D/90S	4	10000	4000
24,6	405	1,6	37,77	S063	90L	6	10000	4000
24,3	420	3,8	38,30	S102	90L/100LR	6	22000	9000
24,2	395	1,9	117,17	S083	80B	2	18000	7200
23,8	414	1,4	58,72	S063	80D/90S	4	10000	4000
23,6	431	1,5	39,38	S062	90L/100LR	6	10000	4000
23,6	428	3,7	59,40	S102	80D/90S	4	22000	9000
23,3	408	2,9	121,29	S103	80B	2	22000	9000
23,2	430	1,5	40,05	S063	90L	6	10000	4000
23,2	439	2,4	40,05	S082	90L/100LR	6	18000	7200
22,6	446	2,2	61,98	S082	80D/90S	4	18000	7200
22,4	426	1,1	126,43	S063	80B	2	10000	4000
22,0	433	1,7	128,73	S083	80B	2	18000	7200
22,0	433	2,8	128,73	S103	80B	2	22000	9000
21,9	466	3,2	42,53	S102	90L/100LR	6	22000	9000
21,6	472	2,2	43,05	S082	90L/100LR	6	18000	7200
21,3	478	1,3	43,64	S062	90L/100LR	6	10000	4000
21,3	464	1,3	65,85	S063	80D/90S	4	10000	4000
21,1	482	2,8	44,00	S102	90L/100LR	6	22000	9000
20,8	486	1,2	67,47	S062	80D/90S	4	10000	4000
20,8	459	1,6	136,34	S083	80B	2	18000	7200

1,10 kW

n2 [rpm]	M2 [Nm]	fs	i	Gear reducer	Motor Size	Pole	Fr2 D [N]	Fr2 C-L [N]
20,7	476	2,1	67,52	S083	80D/90S	4	18000	7200
20,6	489	3,3	67,84	S102	80D/90S	4	22000	9000
20,5	481	1,2	68,25	S063	80D/90S	4	10000	4000
20,2	505	1,2	46,10	S062	90L	6	10000	4000
20,0	476	2,5	141,24	S103	80B	2	22000	9000
19,7	516	3,3	47,13	S102	90L/100LR	6	22000	9000
19,3	529	1,2	48,30	S062	90L/100LR	6	10000	4000
19,0	519	1,2	73,63	S063	80D/90S	4	10000	4000
18,9	527	1,2	49,13	S063	90L	6	10000	4000
18,9	523	1,9	74,18	S083	80D/90S	4	18000	7200
18,9	523	3,1	74,18	S103	80D/90S	4	22000	9000
18,5	550	1,9	50,25	S082	90L/100LR	6	18000	7200
18,5	550	2,7	50,25	S102	90L/100LR	6	22000	9000
17,8	535	1,4	158,76	S083	80B	2	18000	7200
17,4	586	1,1	53,53	S062	90L/100LR	6	10000	4000
17,2	574	1,0	81,43	S063	80D/90S	4	10000	4000
17,2	574	2,8	81,39	S103	80D/90S	4	22000	9000
17,1	594	1,8	54,27	S082	90L/100LR	6	18000	7200
17,1	576	1,7	81,71	S083	80D/90S	4	18000	7200
16,9	602	1,0	55,00	S062	90L	6	10000	4000
16,9	604	2,3	55,14	S102	90L/100LR	6	22000	9000
16,8	593	1,1	55,29	S063	90L	6	10000	4000
16,3	585	2,1	173,78	S103	80B	2	22000	9000
15,9	598	3,8	177,53	S123	80B	2	30000	11200
15,8	630	1,0	58,72	S063	90L	6	10000	4000
15,7	651	2,6	59,40	S102	90L/100LR	6	22000	9000
15,6	633	2,5	89,77	S103	80D/90S	4	22000	9000
15,3	645	1,5	91,49	S083	80D/90S	4	18000	7200
15,3	623	1,2	184,88	S083	80B	2	18000	7200
15,0	679	1,5	61,98	S082	90L/100LR	6	18000	7200
15,0	635	1,9	188,51	S103	80B	2	22000	9000
14,5	655	3,4	194,59	S123	80B	2	30000	11200
14,3	699	0,9	65,85	S063	90L	6	10000	4000
14,0	706	2,3	100,15	S103	80D/90S	4	22000	9000
13,9	710	1,4	100,62	S083	80D/90S	4	18000	7200
13,9	684	1,1	203,11	S083	80B	2	18000	7200
13,9	684	1,8	203,11	S103	80B	2	22000	9000
13,8	691	1,1	205,34	S083	80B	2	18000	7200
13,8	724	1,4	67,52	S083	90L/100LR	6	18000	7200
13,7	743	2,3	67,84	S102	90L/100LR	6	22000	9000
13,4	746	3,8	71,07	S123	100LR	6	30000	11200
13,1	726	3,1	215,60	S123	80B	2	30000	11200

1,10 kW

n2 [rpm]	M2 [Nm]	fs	i	Gear reducer	Motor Size	Pole	Fr2 D [N]	Fr2 C-L [N]
12,7	780	2,1	110,55	S103	80D/90S	4	22000	9000
12,7	750	1,6	222,85	S103	80B	2	22000	9000
12,6	757	1,6	224,76	S103	80B	2	22000	9000
12,5	796	1,3	74,18	S083	90L/100LR	6	18000	7200
12,5	796	2,1	74,18	S103	90L/100LR	6	22000	9000
12,4	794	3,8	112,52	S123	80D/90S	4	30000	11200
12,1	824	3,8	78,46	S123	100LR	6	30000	11200
11,9	826	1,2	117,17	S083	80D/90S	4	18000	7200
11,8	805	2,8	238,93	S123	80B	2	30000	11200
11,5	856	1,9	121,29	S103	80D/90S	4	22000	9000
11,4	876	1,2	81,71	S083	90L/100LR	6	18000	7200
11,4	873	1,9	81,39	S103	90L/100LR	6	22000	9000
11,4	870	3,4	123,33	S123	80D/90S	4	30000	11200
11,1	860	2,6	255,54	S123	80B	2	30000	11200
10,9	908	1,1	128,73	S083	80D/90S	4	18000	7200
10,9	908	1,8	128,73	S103	80D/90S	4	22000	9000
10,9	916	3,4	87,27	S123	100LR	6	30000	11200
10,8	917	3,3	130,04	S123	80D/90S	4	30000	11200
10,5	944	3,2	133,78	S123	80D/90S	4	30000	11200
10,4	963	1,7	89,77	S103	90L/100LR	6	22000	9000
10,3	962	1,0	136,34	S083	80D/90S	4	18000	7200
10,3	923	1,3	274,20	S103	80B	2	22000	9000
10,2	981	1,1	91,49	S083	90L/100LR	6	18000	7200
10,1	946	1,3	280,89	S103	80B	2	22000	9000
10,1	943	2,4	280,10	S123	80B	2	30000	11200
9,9	996	1,6	141,24	S103	80D/90S	4	22000	9000
9,7	984	1,2	292,36	S103	80B	2	22000	9000
9,4	1014	2,2	301,16	S123	80B	2	30000	11200
9,3	1074	1,6	100,15	S103	90L/100LR	6	22000	9000
9,2	1079	1,0	100,62	S083	90L/100LR	6	18000	7200
9,2	1068	2,8	151,43	S123	80D/90S	4	30000	11200
9,0	1096	0,9	158,76	S083	90S	4	18000	7200
9,0	1112	2,8	105,91	S123	100LR	6	30000	11200
8,8	1080	1,1	320,79	S103	80B	2	22000	9000
8,4	1186	1,4	110,55	S103	90L/100LR	6	22000	9000
8,3	1207	2,6	112,52	S123	90L/100LR	6	30000	11200
8,2	1164	1,0	345,60	S103	80B	2	22000	9000
8,2	1158	1,9	343,93	S123	80B	2	30000	11200
8,1	1226	1,3	173,78	S103	80D/90S	4	22000	9000
7,9	1252	2,4	177,53	S123	80D/90S	4	30000	11200
7,7	1301	1,3	121,29	S103	90L/100LR	6	22000	9000
7,7	1296	3,9	123,44	S143	100LR	6	35000	18500

1,10 kW

n2 [rpm]	M2 [Nm]	fs	i	Gear reducer	Motor Size	Pole	Fr2 D [N]	Fr2 C-L [N]
7,5	1323	2,4	123,33	S123	90L/100LR	6	30000	11200
7,4	1330	1,2	188,51	S103	80D/90S	4	22000	9000
7,2	1380	1,2	128,73	S103	90L/100LR	6	22000	9000
7,2	1395	2,3	130,04	S123	90L/100LR	6	30000	11200
7,2	1372	2,2	194,59	S123	80D/90S	4	30000	11200
7,0	1435	2,2	133,78	S123	90L/100LR	6	30000	11200
6,9	1433	1,1	203,11	S103	80D/90S	4	22000	9000
6,8	1466	3,5	139,64	S143	100LR	6	35000	18500
6,6	1515	1,1	141,24	S103	90L/100LR	6	22000	9000
6,5	1521	2,0	215,60	S123	80D/90S	4	30000	11200
6,4	1565	3,2	149,10	S143	100LR	6	35000	18500
6,3	1572	1,0	222,85	S103	80D/90S	4	22000	9000
6,2	1585	1,0	224,76	S103	80D/90S	4	22000	9000
6,1	1624	1,9	151,43	S123	90L/100LR	6	30000	11200
6,0	1653	2,4	157,49	S143	100LR	6	35000	18500
5,9	1685	1,8	238,93	S123	80D/90S	4	30000	11200
5,5	1802	1,7	255,54	S123	80D/90S	4	30000	11200
5,5	1801	2,7	171,55	S143	100LR	6	35000	18500
5,4	1864	0,9	173,78	S103	90L/100LR	6	22000	9000
5,4	1841	2,4	175,41	S143	100LR	6	35000	18500
5,2	1904	1,7	177,53	S123	90L/100LR	6	30000	11200
5,0	1976	1,5	280,10	S123	80D/90S	4	30000	11200
4,8	2087	1,5	194,59	S123	90L/100LR	6	30000	11200
4,8	2065	2,4	196,74	S143	100LR	6	35000	18500
4,6	2124	1,4	301,16	S123	80D/90S	4	30000	11200
4,3	2312	1,4	215,60	S123	90L/100LR	6	30000	11200
4,3	2337	2,1	222,57	S143	100LR	6	35000	18500
4,1	2426	1,2	343,93	S123	80D/90S	4	30000	11200
4,0	2495	2,1	237,63	S143	100LR	6	35000	18500
3,9	2562	1,2	238,93	S123	90L/100LR	6	30000	11200
3,6	2740	1,1	255,54	S123	90L/100LR	6	30000	11200
3,5	2870	1,8	273,41	S143	100LR	6	35000	18500
3,3	3004	1,0	280,10	S123	90L/100LR	6	30000	11200
3,1	3230	1,0	301,16	S123	90L/100LR	6	30000	11200

1,50 kW

n2 [rpm]	M2 [Nm]	fs	i	Gear reducer	Motor Size	Pole	Fr2 D [N]	Fr2 C-L [N]
325,8	41	3,1	8,63	S052	80C/90S	2	3230	3230
252,2	53	2,7	11,14	S052	80C/90S	2	3467	3467
234,2	57	2,6	12,00	S052	80C/90S	2	3537	3537
205,8	64	2,4	13,66	S052	80C/90S	2	3660	3660

1,50 kW

n2 [rpm]	M2 [Nm]	fs	i	Gear reducer	Motor Size	Pole	Fr2 D [N]	Fr2 C-L [N]
184,0	72	2,5	15,27	S052	80C/90S	2	3767	3767
172,5	77	2,3	16,29	S052	80C/90S	2	3829	3829
162,3	85	2,0	8,63	S052	90L/90LA	4	3871	3871
156,9	88	3,8	8,92	S062	90L/90LA	4	7030	2812
150,8	88	2,0	18,63	S052	80C/90S	2	3959	3959
146,7	94	3,8	9,55	S062	90L/90LA	4	7162	2865
145,7	91	3,7	19,29	S062	80C/90S	2	7196	2878
143,7	92	3,7	19,55	S062	80C/90S	2	7223	2889
142,4	93	1,9	19,73	S052	80C/90S	2	4014	4014
133,6	99	2,0	21,04	S052	80C/90S	2	4076	4076
131,5	105	3,4	10,65	S062	90L/90LA	4	7378	2951
130,5	102	1,9	21,53	S052	80C/90S	2	4098	4098
125,7	109	1,7	11,14	S052	90L/90LA	4	4112	4112
121,2	109	3,2	23,18	S062	80C/90S	2	7566	3026
119,6	115	3,4	11,71	S062	90L/90LA	4	7568	3027
118,3	112	3,1	23,75	S062	80C/90S	2	7615	3046
116,8	114	1,7	24,07	S052	80C/90S	2	4204	4204
116,7	118	1,7	12,00	S052	90L/90LA	4	4181	4181
116,3	119	2,9	8,00	S062	100L/100LA	6	7617	3047
111,8	119	3,0	25,14	S062	80C/90S	2	7732	3093
111,5	119	1,8	25,20	S052	80C/90S	2	4247	4247
109,0	122	1,8	25,79	S052	80C/90S	2	4269	4269
107,8	129	1,4	8,63	S052	100L/100LA	6	4245	4245
107,2	128	3,3	13,06	S062	90L/90LA	4	7788	3115
104,8	131	3,2	13,36	S062	90L/90LA	4	7834	3134
104,2	133	2,6	8,92	S062	100L/100LA	6	7837	3135
102,5	134	1,6	13,66	S052	90L/90LA	4	4298	4298
101,6	131	2,8	27,66	S062	80C/90S	2	7927	3171
101,0	131	1,7	27,81	S052	80C/90S	2	4339	4339
97,4	143	2,7	9,55	S062	100L/100LA	6	7974	3189
93,7	142	1,5	30,00	S052	80C/90S	2	4408	4408
93,7	142	2,6	30,00	S062	80C/90S	2	8095	3238
91,7	150	1,6	15,27	S052	90L/90LA	4	4397	4397
87,8	157	2,9	15,94	S062	90L/90LA	4	8194	3277
87,4	159	2,4	10,65	S062	100L/100LA	6	8195	3278
86,6	159	2,8	16,16	S062	90L/90LA	4	8222	3289
86,3	154	1,5	32,55	S052	80C/90S	2	4481	4481
86,0	160	1,5	16,29	S052	90L/90LA	4	4452	4452
85,2	156	1,4	33,00	S052	80C/90S	2	4493	4493
83,7	155	2,9	33,57	S063	80C/90S	2	8349	3340
83,5	166	1,2	11,14	S052	100L/100LA	6	4467	4467
82,8	160	2,5	33,93	S062	80C/90S	2	8350	3340

1,50 kW

n2 [rpm]	M2 [Nm]	fs	i	Gear reducer	Motor Size	Pole	Fr2 D [N]	Fr2 C-L [N]
82,4	161	1,4	34,09	S052	80C/90S	2	4521	4521
79,4	175	2,3	11,71	S062	100L/100LA	6	8388	3355
77,5	179	1,2	12,00	S052	100L/100LA	6	4527	4527
77,0	169	1,6	36,50	S053	80C/90S	2	4600	4600
76,9	173	1,4	36,55	S052	80C/90S	2	4580	4580
76,8	173	2,6	36,57	S062	80C/90S	2	8506	3402
75,1	183	1,3	18,63	S052	90L/90LA	4	4562	4562
74,4	175	2,6	37,77	S063	80C/90S	2	8597	3439
72,6	189	2,4	19,29	S062	90L/90LA	4	8582	3433
72,5	183	1,4	38,75	S052	80C/90S	2	4629	4629
71,6	192	2,4	19,55	S062	90L/90LA	4	8609	3444
71,4	186	2,4	39,38	S062	80C/90S	2	8659	3464
71,2	195	2,3	13,06	S062	100L/100LA	6	8608	3443
71,0	194	1,2	19,73	S052	90L/90LA	4	4607	4607
70,4	188	1,4	39,90	S052	80C/90S	2	4652	4652
70,2	185	2,4	40,05	S063	80C/90S	2	8719	3488
70,2	189	4,0	40,05	S082	80C ⁽¹⁾	2	18000	5322
69,6	199	2,2	13,36	S062	100L/100LA	6	8654	3461
69,5	198	3,9	20,14	S082	90L/90LA	4	18000	5331
68,1	204	1,1	13,66	S052	100L/100LA	6	4626	4626
66,6	207	1,3	21,04	S052	90L/90LA	4	4655	4655
66,2	210	3,8	14,04	S082	100L/100LA	6	18000	5409
65,9	201	1,3	42,63	S052	80C/90S	2	4704	4704
65,3	203	3,7	43,05	S082	80C/90S	2	18000	5442
65,0	211	1,2	21,53	S052	90L/90LA	4	4672	4672
64,4	206	2,2	43,64	S062	80C/90S	2	8871	3548
63,3	217	3,7	22,13	S082	90L/90LA	4	18000	5486
61,1	217	1,2	46,00	S052	80C/90S	2	4761	4761
61,0	218	2,1	46,10	S062	80C/90S	2	8983	3593
60,9	228	1,1	15,27	S052	100L/100LA	6	4705	4705
60,4	228	2,1	23,18	S062	90L/90LA	4	8951	3581
60,3	230	3,5	15,43	S082	100L/100LA	6	18000	5566
59,6	218	1,2	47,14	S053	80C/90S	2	4806	4806
59,5	223	1,2	47,20	S052	80C/90S	2	4780	4780
59,1	235	3,4	15,73	S082	100L/100LA	6	18000	5598
58,9	233	2,0	23,75	S062	90L/90LA	4	9000	3600
58,4	238	2,0	15,94	S062	100L/100LA	6	9005	3602
58,3	236	3,4	24,00	S082	90L/90LA	4	18000	5624
58,2	236	1,1	24,07	S052	90L/90LA	4	4748	4748
58,2	228	2,0	48,30	S062	80C/90S	2	9078	3631
57,5	241	2,0	16,16	S062	100L/100LA	6	9032	3613
57,2	227	2,0	49,13	S063	80C/90S	2	9143	3657

⁽¹⁾ Available only with brake motor (TBS)

5.1 S GEARED MOTORS (50Hz)

1,50 kW

n2 [rpm]	M2 [Nm]	fs	i	Gear reducer	Motor Size	Pole	Fr2 D [N]	Fr2 C-L [N]
57,1	243	1,0	16,29	S052	100L/100LA	6	4746	4746
55,9	237	3,2	50,25	S082	80C/90S	2	18000	5704
55,7	247	1,9	25,14	S062	90L/90LA	4	9112	3645
55,6	248	1,2	25,20	S052	90L/90LA	4	4777	4777
54,3	253	1,1	25,79	S052	90L/90LA	4	4791	4791
53,8	247	1,1	52,25	S052	80C/90S	2	4849	4849
53,8	258	3,1	17,29	S082	100L/100LA	6	18000	5762
53,7	256	3,1	26,05	S082	90L/90LA	4	18000	5765
52,5	253	1,8	53,53	S062	80C/90S	2	9285	3714
51,8	256	2,9	54,27	S082	80C/90S	2	18000	5839
51,3	268	3,4	27,29	S082	90L/90LA	4	18000	5846
51,1	260	1,7	55,00	S062	80C/90S	2	9338	3735
51,0	260	3,7	55,14	S102	80C/90S	2	22000	7244
50,8	256	1,8	55,29	S063	80C/90S	2	9383	3753
50,6	272	1,8	27,66	S062	90L/90LA	4	9296	3719
50,3	273	1,1	27,81	S052	90L/90LA	4	4834	4834
49,9	278	0,9	18,63	S052	100L/100LA	6	4822	4822
49,7	262	1,0	57,79	S053	90S	2	4929	4929
48,9	284	2,8	19,03	S082	100L/100LA	6	18000	5930
48,8	282	3,2	28,67	S082	90L/90LA	4	18000	5934
48,2	288	1,6	19,29	S062	100L/100LA	6	9371	3748
47,9	272	1,7	58,72	S063	80C/90S	2	9503	3801
47,6	292	1,7	19,55	S062	100L/100LA	6	9396	3758
47,3	291	3,1	29,60	S082	90L/90LA	4	18000	5991
46,7	295	1,0	30,00	S052	90L/90LA	4	4871	4871
46,7	295	1,7	30,00	S062	90L/90LA	4	9450	3780
46,2	301	2,7	20,14	S082	100L/100LA	6	18000	6031
45,3	293	2,6	61,98	S082	80C/90S	2	18000	6077
44,1	312	3,2	31,78	S082	90L/90LA	4	18000	6119
43,0	320	0,9	32,55	S052	90L/90LA	4	4905	4905
42,7	305	1,5	65,85	S063	80C/90S	2	9727	3891
42,4	324	0,9	33,00	S052	90L/90LA	4	4910	4910
42,0	330	2,5	22,13	S082	100L/100LA	6	18000	6202
41,7	330	0,9	34,09	S052	90L	4	4917	4917
41,7	319	1,4	67,47	S062	80C/90S	2	9731	3893
41,7	323	1,9	33,57	S063	90L/90LA	4	9699	3880
41,6	312	2,4	67,52	S083	80C/90S	2	18000	6241
41,4	320	3,7	67,84	S102	80C/90S	2	22000	7726
41,3	333	1,6	33,93	S062	90L/90LA	4	9675	3870
41,2	316	1,4	68,25	S063	80C/90S	2	9795	3918
40,1	346	1,4	23,18	S062	100L/100LA	6	9702	3881
40,1	343	2,9	34,91	S082	90L/90LA	4	18000	6293

1,50 kW

n2 [rpm]	M2 [Nm]	fs	i	Gear reducer	Motor Size	Pole	Fr2 D [N]	Fr2 C-L [N]
39,4	349	2,9	35,50	S082	90L/90LA	4	18000	6324
39,2	355	1,4	23,75	S062	100L/100LA	6	9744	3898
38,8	358	2,3	24,00	S082	100L/100LA	6	18000	6353
38,4	351	1,0	36,50	S053	90L/90LA	4	4984	4984
38,3	359	0,9	36,55	S052	90L/90LA	4	4941	4941
38,3	359	1,7	36,57	S062	90L/90LA	4	9806	3922
38,2	340	1,3	73,63	S063	80C/90S	2	9937	3975
37,9	343	2,2	74,18	S083	80C/90S	2	18000	6418
37,9	343	3,5	74,18	S103	80C/90S	2	22000	7948
37,1	363	1,7	37,77	S063	90L/90LA	4	9909	3964
37,0	376	1,3	25,14	S062	100L/100LA	6	9840	3936
36,6	376	4,0	38,30	S102	90LA ⁽¹⁾	4	22000	8020
35,7	389	2,2	26,05	S082	100L/100LA	6	18000	6508
35,6	386	0,9	39,90	S052	90L	4	4954	4954
35,6	387	1,6	39,38	S062	90L/90LA	4	9929	3972
35,0	385	1,6	40,05	S063	90L/90LA	4	10000	4000
35,0	393	2,5	40,05	S082	90L/90LA	4	18000	6552
34,5	377	1,2	81,43	S063	80C/90S	2	10000	4000
34,5	376	3,2	81,39	S103	80C/90S	2	22000	8178
34,4	378	2,0	81,71	S083	80C/90S	2	18000	6604
34,1	408	2,3	27,29	S082	100L/100LA	6	18000	6597
33,6	413	1,2	27,66	S062	100L/100LA	6	9993	3997
32,9	418	3,4	42,53	S102	90L/90LA	4	22000	8281
32,5	423	2,4	43,05	S082	90L/90LA	4	18000	6691
32,4	428	2,2	28,67	S082	100L/100LA	6	18000	6692
32,1	429	1,4	43,64	S062	90L/90LA	4	10000	4000
31,8	432	3,0	44,00	S102	90L/90LA	4	22000	8368
31,4	442	2,1	29,60	S082	100L/100LA	6	18000	6754
31,3	415	2,9	89,77	S103	80C/90S	2	22000	8427
31,1	446	3,5	29,87	S102	100L/100LA	6	22000	8420
31,0	448	1,2	30,00	S062	100L/100LA	6	10000	4000
30,7	423	1,8	91,49	S083	80C/90S	2	18000	6826
30,4	453	1,3	46,10	S062	90L/90LA	4	10000	4000
29,7	463	3,5	47,13	S102	90L/90LA	4	22000	8544
29,3	475	2,2	31,78	S082	100L/100LA	6	18000	6894
29,0	474	1,3	48,30	S062	90L/90LA	4	10000	4000
28,7	484	3,3	32,40	S102	100L/100LA	6	22000	8630
28,5	473	1,3	49,13	S063	90L/90LA	4	10000	4000
28,1	463	2,6	100,15	S103	80C/90S	2	22000	8713
27,9	494	2,0	50,25	S082	90L/90LA	4	18000	6996
27,9	465	1,6	100,62	S083	80C/90S	2	18000	7017
27,9	494	2,8	50,25	S102	90L/90LA	4	22000	8711

⁽¹⁾ Available only with brake motor (TBS)

1,50 kW

n2 [rpm]	M2 [Nm]	fs	i	Gear reducer	Motor Size	Pole	Fr2 D [N]	Fr2 C-L [N]
27,4	507	1,1	33,93	S062	100L/100LA	6	10000	4000
26,6	521	2,0	34,91	S082	100L/100LA	6	18000	7081
26,6	521	2,8	34,91	S102	100L/100LA	6	22000	8826
26,2	526	1,1	53,53	S062	90L/90LA	4	10000	4000
26,2	530	2,0	35,50	S082	100L/100LA	6	18000	7115
25,8	533	1,9	54,27	S082	90L/90LA	4	18000	7151
25,5	540	1,1	55,00	S062	90L/90LA	4	10000	4000
25,4	546	1,2	36,57	S062	100L/100LA	6	10000	4000
25,4	542	2,4	55,14	S102	90L/90LA	4	22000	8958
25,4	511	2,3	110,55	S103	80C/90S	2	22000	8977
25,3	532	1,1	55,29	S063	90L/90LA	4	10000	4000
24,3	572	2,8	38,30	S102	100L/100LA	6	22000	9000
24,0	542	1,4	117,17	S083	80C/90S	2	18000	7200
23,8	565	1,1	58,72	S063	90L/90LA	4	10000	4000
23,6	588	1,1	39,38	S062	100L/100LA	6	10000	4000
23,6	583	2,7	59,40	S102	90L/90LA	4	22000	9000
23,2	598	1,8	40,05	S082	100L/100LA	6	18000	7200
23,2	561	2,1	121,29	S103	80C/90S	2	22000	9000
22,8	570	3,9	123,33	S123	80C/90S	2	30000	11200
22,6	609	1,6	61,98	S082	90L/90LA	4	18000	7200
21,9	635	2,3	42,53	S102	100L/100LA	6	22000	9000
21,8	595	1,3	128,73	S083	80C/90S	2	18000	7200
21,8	595	2,0	128,73	S103	80C/90S	2	22000	9000
21,6	643	1,6	43,05	S082	100L/100LA	6	18000	7200
21,6	601	3,7	130,04	S123	80C/90S	2	30000	11200
21,3	652	1,0	43,64	S062	100L/100LA	6	10000	4000
21,3	633	0,9	65,85	S063	90L/90LA	4	10000	4000
21,1	657	2,1	44,00	S102	100L/100LA	6	22000	9000
21,0	619	3,6	133,78	S123	80C/90S	2	30000	11200
20,8	663	0,9	67,47	S062	90L/90LA	4	10000	4000
20,8	667	3,8	44,63	S122	100L/100LA	6	30000	11200
20,7	649	1,5	67,52	S083	90L/90LA	4	18000	7200
20,6	630	1,2	136,34	S083	80C/90S	2	18000	7200
20,6	666	2,4	67,84	S102	90L/90LA	4	22000	9000
20,5	656	0,9	68,25	S063	90L/90LA	4	10000	4000
19,9	653	1,8	141,24	S103	80C/90S	2	22000	9000
19,7	704	2,4	47,13	S102	100L/100LA	6	22000	9000
19,0	732	3,4	49,04	S122	100L/100LA	6	30000	11200
18,9	713	1,4	74,18	S083	90L/90LA	4	18000	7200
18,9	713	2,2	74,18	S103	90L/90LA	4	22000	9000
18,6	700	3,2	151,43	S123	80C/90S	2	30000	11200
18,5	750	1,4	50,25	S082	100L/100LA	6	18000	7200

5.1 S GEARED MOTORS (50Hz)

1,50 kW

n2 [rpm]	M2 [Nm]	fs	i	Gear reducer	Motor Size	Pole	Fr2 D [N]	Fr2 C-L [N]
18,5	750	2,0	50,25	S102	100L/100LA	6	22000	9000
17,7	734	1,0	158,76	S083	80C/90S	2	18000	7200
17,3	803	3,4	53,75	S122	100L/100LA	6	30000	11200
17,2	783	2,0	81,39	S103	90L/90LA	4	22000	9000
17,1	810	1,3	54,27	S082	100L/100LA	6	18000	7200
17,1	786	1,3	81,71	S083	90L/90LA	4	18000	7200
16,9	823	1,7	55,14	S102	100L/100LA	6	22000	9000
16,2	804	1,5	173,78	S103	80C/90S	2	22000	9000
15,8	821	2,7	177,53	S123	80C/90S	2	30000	11200
15,7	887	1,9	59,40	S102	100L/100LA	6	22000	9000
15,6	863	1,9	89,77	S103	90L/90LA	4	22000	9000
15,3	880	1,1	91,49	S083	90L/90LA	4	18000	7200
15,0	926	1,1	61,98	S082	100L/100LA	6	18000	7200
14,9	872	1,4	188,51	S103	80C/90S	2	22000	9000
14,4	900	2,5	194,59	S123	80C/90S	2	30000	11200
14,3	948	3,0	64,84	S123	100L/100LA	6	30000	11200
14,1	986	3,2	66,00	S122	100L/100LA	6	30000	11200
14,0	963	1,7	100,15	S103	90L/90LA	4	22000	9000
13,9	968	1,0	100,62	S083	90L/90LA	4	18000	7200
13,8	987	1,1	67,52	S083	100L/100LA	6	18000	7200
13,8	939	1,3	203,11	S103	80C/90S	2	22000	9000
13,7	1013	1,7	67,84	S102	100L/100LA	6	22000	9000
13,1	1039	2,7	71,07	S123	100L/100LA	6	30000	11200
13,0	997	2,3	215,60	S123	80C/90S	2	30000	11200
12,7	1063	1,5	110,55	S103	90L/90LA	4	22000	9000
12,6	1031	1,2	222,85	S103	80C/90S	2	22000	9000
12,5	1085	1,0	74,18	S083	100L/100LA	6	18000	7200
12,5	1085	1,5	74,18	S103	100L/100LA	6	22000	9000
12,5	1039	1,2	224,76	S103	80C/90S	2	22000	9000
12,4	1082	2,8	112,52	S123	90L/90LA	4	30000	11200
12,2	1103	0,9	117,17	S083	90L	4	18000	7200
11,9	1147	2,7	78,46	S123	100L/100LA	6	30000	11200
11,8	1105	2,0	238,93	S123	80C/90S	2	30000	11200
11,7	1162	3,8	79,45	S143	100L/100LA	6	35000	18500
11,5	1167	1,4	121,29	S103	90L/90LA	4	22000	9000
11,4	1190	1,4	81,39	S103	100L/100LA	6	22000	9000
11,4	1186	2,5	123,33	S123	90L/90LA	4	30000	11200
11,0	1182	1,9	255,54	S123	80C/90S	2	30000	11200
10,9	1238	1,3	128,73	S103	90L/90LA	4	22000	9000
10,8	1251	2,4	130,04	S123	90L/90LA	4	30000	11200
10,7	1276	2,5	87,27	S123	100L/100LA	6	30000	11200
10,5	1287	2,3	133,78	S123	90L/90LA	4	30000	11200

1,50 kW

n2 [rpm]	M2 [Nm]	fs	i	Gear reducer	Motor Size	Pole	Fr2 D [N]	Fr2 C-L [N]
10,4	1313	1,3	89,77	S103	100L/100LA	6	22000	9000
10,0	1295	1,7	280,10	S123	80C/90S	2	30000	11200
9,9	1358	1,2	141,24	S103	90L/90LA	4	22000	9000
9,4	1445	3,2	98,81	S143	100L/100LA	6	35000	18500
9,3	1465	1,1	100,15	S103	100L/100LA	6	22000	9000
9,3	1393	1,6	301,16	S123	80C/90S	2	30000	11200
9,2	1457	2,1	151,43	S123	90L/90LA	4	30000	11200
8,8	1549	2,0	105,91	S123	100L/100LA	6	30000	11200
8,5	1609	3,1	110,05	S143	100L/100LA	6	35000	18500
8,4	1617	1,0	110,55	S103	100L/100LA	6	22000	9000
8,3	1645	1,9	112,52	S123	100L/100LA	6	30000	11200
8,2	1590	1,4	343,93	S123	80C/90S	2	30000	11200
8,1	1671	1,0	173,78	S103	90L/90LA	4	22000	9000
7,9	1708	1,8	177,53	S123	90L/90LA	4	30000	11200
7,7	1774	0,9	121,29	S103	100L/100LA	6	22000	9000
7,6	1775	0,9	188,51	S103	90L	4	22000	9000
7,5	1804	1,7	123,33	S123	100L/100LA	6	30000	11200
7,5	1805	2,8	123,44	S143	100L/100LA	6	35000	18500
7,3	1862	0,9	128,73	S103	100L	6	22000	9000
7,2	1902	1,7	130,04	S123	100L/100LA	6	30000	11200
7,2	1872	1,6	194,59	S123	90L/90LA	4	30000	11200
7,0	1956	1,6	133,78	S123	100L/100LA	6	30000	11200
6,7	2042	2,5	139,64	S143	100L/100LA	6	35000	18500
6,5	2074	1,4	215,60	S123	90L/90LA	4	30000	11200
6,2	2180	2,3	149,10	S143	100L/100LA	6	35000	18500
6,1	2215	1,4	151,43	S123	100L/100LA	6	30000	11200
5,9	2298	1,3	238,93	S123	90L/90LA	4	30000	11200
5,9	2303	1,7	157,49	S143	100L/100LA	6	35000	18500
5,5	2458	1,2	255,54	S123	90L/90LA	4	30000	11200
5,4	2509	2,0	171,55	S143	100L/100LA	6	35000	18500
5,3	2565	1,7	175,41	S143	100L/100LA	6	35000	18500
5,2	2596	1,2	177,53	S123	100L/100LA	6	30000	11200
5,0	2694	1,1	280,10	S123	90L/90LA	4	30000	11200
4,8	2846	1,1	194,59	S123	100L/100LA	6	30000	11200
4,7	2877	1,7	196,74	S143	100L/100LA	6	35000	18500
4,6	2897	1,0	301,16	S123	90L/90LA	4	30000	11200
4,3	3153	1,0	215,60	S123	100L/100LA	6	30000	11200
4,2	3255	1,5	222,57	S143	100L/100LA	6	35000	18500
4,1	3308	0,9	343,93	S123	90L/90LA	4	30000	11200
3,9	3494	0,9	238,93	S123	100L/100LA	6	30000	11200
3,9	3475	1,5	237,63	S143	100L/100LA	6	35000	18500
3,4	3998	1,3	273,41	S143	100L/100LA	6	35000	18500

1,85 kW

n2 [rpm]	M2 [Nm]	fs	i	Gear reducer	Size	Motor Pole	Fr2 D [N]	Fr2 C-L [N]
175,0	97	3,4	8,00	S062	90LB ⁽¹⁾	4	6703	2681
162,3	104	1,6	8,63	S052	90LB ⁽¹⁾	4	3756	3756
156,9	108	3,1	8,92	S062	90LB ⁽¹⁾	4	6900	2760
146,7	116	3,1	9,55	S062	90LB ⁽¹⁾	4	7023	2809
131,5	129	2,8	10,65	S062	90LB ⁽¹⁾	4	7223	2889
125,7	135	1,4	11,14	S052	90LB ⁽¹⁾	4	3963	3963
119,6	142	2,7	11,71	S062	90LB ⁽¹⁾	4	7398	2959
116,7	145	1,4	12,00	S052	90LB ⁽¹⁾	4	4021	4021
116,3	147	2,4	8,00	S062	100LB	6	7441	2976
107,8	159	1,1	8,63	S052	100LB	6	4071	4071
107,2	158	2,7	13,06	S062	90LB ⁽¹⁾	4	7599	3039
104,8	162	2,6	13,36	S062	90LB ⁽¹⁾	4	7640	3056
104,2	164	2,1	8,92	S062	100LB	6	7640	3056
102,5	165	1,3	13,66	S052	90LB ⁽¹⁾	4	4116	4116
97,4	176	2,1	9,55	S062	100LB	6	7763	3105
93,5	183	3,7	9,94	S082	100LB	6	16905	4830
91,7	185	1,3	15,27	S052	90LB ⁽¹⁾	4	4193	4193
87,8	193	2,3	15,94	S062	90LB ⁽¹⁾	4	7962	3185
87,4	196	1,9	10,65	S062	100LB	6	7960	3184
86,6	196	2,3	16,16	S062	90LB ⁽¹⁾	4	7987	3195
86,0	197	1,2	16,29	S052	90LB ⁽¹⁾	4	4235	4235
83,5	205	1,0	11,14	S052	100LB	6	4241	4241
80,9	210	3,7	17,29	S082	90LB ⁽¹⁾	4	17673	5049
80,1	214	3,4	11,61	S082	100LB	6	17721	5063
79,4	216	1,9	11,71	S062	100LB	6	8129	3252
77,5	221	1,0	12,00	S052	100LB	6	4284	4284
75,1	226	1,1	18,63	S052	90LB ⁽¹⁾	4	4314	4314
73,6	231	3,3	19,03	S082	90LB ⁽¹⁾	4	18000	5198
72,9	235	3,4	12,75	S082	100LB	6	18000	5209
72,6	234	1,9	19,29	S062	90LB ⁽¹⁾	4	8302	3321
71,6	237	1,9	19,55	S062	90LB ⁽¹⁾	4	8325	3330
71,2	241	1,8	13,06	S062	100LB	6	8320	3328
71,0	239	1,0	19,73	S052	90LB ⁽¹⁾	4	4344	4344
69,6	246	1,8	13,36	S062	100LB	6	8359	3343
69,5	244	3,2	20,14	S082	90LB ⁽¹⁾	4	18000	5287
66,6	255	1,0	21,04	S052	90LB ⁽¹⁾	4	4375	4375
66,2	259	3,1	14,04	S082	100LB	6	18000	5363
65,0	261	1,0	21,53	S052	90LB ⁽¹⁾	4	4385	4385
63,3	268	3,0	22,13	S082	90LB ⁽¹⁾	4	18000	5439
60,4	281	1,7	23,18	S062	90LB ⁽¹⁾	4	8615	3446
60,3	284	2,8	15,43	S082	100LB	6	18000	5515
59,1	290	2,8	15,73	S082	100LB	6	18000	5547

⁽¹⁾ Available only with brake motor (TBS)

1,85 kW

n2 [rpm]	M2 [Nm]	fs	i	Gear reducer	Size	Motor Pole	Fr2 D [N]	Fr2 C-L [N]
58,9	288	1,6	23,75	S062	90LB ⁽¹⁾	4	8655	3462
58,4	294	1,6	15,94	S062	100LB	6	8653	3461
58,3	291	2,8	24,00	S082	90LB ⁽¹⁾	4	18000	5572
57,5	298	1,6	16,16	S062	100LB	6	8675	3470
55,7	305	1,6	25,14	S062	90LB ⁽¹⁾	4	8747	3499
55,6	305	0,9	25,20	S052	90LB ⁽¹⁾	4	4442	4442
54,3	312	0,9	25,79	S052	90LB ⁽¹⁾	4	4448	4448
53,8	319	2,5	17,29	S082	100LB	6	18000	5705
53,7	316	2,5	26,05	S082	90LB ⁽¹⁾	4	18000	5709
51,3	331	2,7	27,29	S082	90LB ⁽¹⁾	4	18000	5788
50,6	335	1,4	27,66	S062	90LB ⁽¹⁾	4	8895	3558
48,9	351	2,3	19,03	S082	100LB	6	18000	5868
48,8	347	2,6	28,67	S082	90LB ⁽¹⁾	4	18000	5872
48,2	355	1,3	19,29	S062	100LB	6	8945	3578
47,6	360	1,3	19,55	S062	100LB	6	8964	3586
47,3	359	2,5	29,60	S082	90LB ⁽¹⁾	4	18000	5927
46,7	363	1,4	30,00	S062	90LB ⁽¹⁾	4	9014	3606
46,2	371	2,2	20,14	S082	100LB	6	18000	5965
44,7	384	3,8	20,83	S102	100LB	6	22000	7485
44,1	385	2,6	31,78	S082	90LB ⁽¹⁾	4	18000	6051
43,2	393	3,8	32,40	S102	90LB ⁽¹⁾	4	22000	7562
42,0	408	2,1	22,13	S082	100LB	6	18000	6130
42,0	408	3,6	22,13	S102	100LB	6	22000	7623
41,7	398	1,5	33,57	S063	90LB ⁽¹⁾	4	9222	3689
41,3	411	1,3	33,93	S062	90LB ⁽¹⁾	4	9182	3673
40,1	427	1,2	23,18	S062	100LB	6	9191	3676
40,1	423	2,4	34,91	S082	90LB ⁽¹⁾	4	18000	6217
40,1	423	3,3	34,91	S102	90LB ⁽¹⁾	4	22000	7736
39,4	430	2,3	35,50	S082	90LB ⁽¹⁾	4	18000	6247
39,2	437	1,1	23,75	S062	100LB	6	9220	3688
38,8	442	1,9	24,00	S082	100LB	6	18000	6275
38,3	443	1,4	36,57	S062	90LB ⁽¹⁾	4	9274	3710
38,3	447	3,5	24,28	S102	100LB	6	22000	7840
37,1	448	1,3	37,77	S063	90LB ⁽¹⁾	4	9372	3749
37,0	463	1,1	25,14	S062	100LB	6	9285	3714
36,6	464	3,2	38,30	S102	90LB ⁽¹⁾	4	22000	7955
35,7	480	1,8	26,05	S082	100LB	6	18000	6423
35,6	477	1,3	39,38	S062	90LB ⁽¹⁾	4	9357	3743
35,3	485	3,2	26,33	S102	100LB	6	22000	8034
35,0	475	1,3	40,05	S063	90LB ⁽¹⁾	4	9439	3776
35,0	485	2,1	40,05	S082	90LB ⁽¹⁾	4	18000	6466
34,1	503	1,9	27,29	S082	100LB	6	18000	6508

⁽¹⁾ Available only with brake motor (TBS)

1,85 kW

n2 [rpm]	M2 [Nm]	fs	i	Gear reducer	Motor Size	Pole	Fr2 D [N]	Fr2 C-L [N]
33,6	509	1,0	27,66	S062	100LB	6	9382	3753
32,9	515	2,7	42,53	S102	90LB ⁽¹⁾	4	22000	8209
32,5	522	1,9	43,05	S082	90LB ⁽¹⁾	4	18000	6599
32,4	528	1,8	28,67	S082	100LB	6	18000	6599
32,1	529	1,1	43,64	S062	90LB ⁽¹⁾	4	9457	3783
31,8	533	2,4	44,00	S102	90LB ⁽¹⁾	4	22000	8293
31,4	545	1,7	29,60	S082	100LB	6	18000	6657
31,1	550	2,9	29,87	S102	100LB	6	22000	8342
31,0	553	1,0	30,00	S062	100LB	6	9451	3780
30,4	558	1,1	46,10	S062	90LB ⁽¹⁾	4	9502	3801
29,7	571	2,8	47,13	S102	90LB ⁽¹⁾	4	22000	8464
29,3	585	1,8	31,78	S082	100LB	6	18000	6790
29,0	585	1,0	48,30	S062	90LB ⁽¹⁾	4	9535	3814
28,7	597	2,6	32,40	S102	100LB	6	22000	8546
28,5	583	1,0	49,13	S063	90LB ⁽¹⁾	4	9625	3850
27,9	609	1,6	50,25	S082	90LB ⁽¹⁾	4	18000	6888
27,9	609	2,3	50,25	S102	90LB ⁽¹⁾	4	22000	8626
27,4	625	0,9	33,93	S062	100LB	6	9529	3812
26,6	643	1,6	34,91	S082	100LB	6	18000	6967
26,6	643	2,3	34,91	S102	100LB	6	22000	8736
26,2	648	0,9	53,53	S062	90LB ⁽¹⁾	4	9591	3836
26,2	654	1,6	35,50	S082	100LB	6	18000	6999
26,0	651	4,0	53,75	S122	90LB ⁽¹⁾	4	30000	11200
25,8	657	1,5	54,27	S082	90LB ⁽¹⁾	4	18000	7034
25,5	666	0,9	55,00	S062	90LB ⁽¹⁾	4	9601	3840
25,4	674	0,9	36,57	S062	100LB	6	9559	3824
25,4	668	1,9	55,14	S102	90LB ⁽¹⁾	4	22000	8864
25,3	656	0,9	55,29	S063	90LB ⁽¹⁾	4	9691	3876
24,3	706	2,2	38,30	S102	100LB	6	22000	8976
23,6	720	2,2	59,40	S102	90LB ⁽¹⁾	4	22000	9000
23,2	738	1,4	40,05	S082	100LB	6	18000	7200
22,6	751	1,3	61,98	S082	90LB ⁽¹⁾	4	18000	7200
21,9	783	1,9	42,53	S102	100LB	6	22000	9000
21,6	793	1,3	43,05	S082	100LB	6	18000	7200
21,3	803	3,9	43,60	S122	100LB	6	30000	11200
21,2	800	3,8	66,00	S122	90LB ⁽¹⁾	4	30000	11200
21,1	810	1,7	44,00	S102	100LB	6	22000	9000
20,8	822	3,1	44,63	S122	100LB	6	30000	11200
20,7	801	1,2	67,52	S083	90LB ⁽¹⁾	4	18000	7200
20,6	822	1,9	67,84	S102	90LB ⁽¹⁾	4	22000	9000
19,7	868	1,9	47,13	S102	100LB	6	22000	9000
19,0	903	2,8	49,04	S122	100LB	6	30000	11200

⁽¹⁾ Available only with brake motor (TBS)

1,85 kW

n2 [rpm]	M2 [Nm]	fs	i	Gear reducer	Size	Motor Pole	Fr2 D [N]	Fr2 C-L [N]
18,9	880	1,1	74,18	S083	90LB ⁽¹⁾	4	18000	7200
18,9	880	1,8	74,18	S103	90LB ⁽¹⁾	4	22000	9000
18,5	926	1,1	50,25	S082	100LB	6	18000	7200
18,5	926	1,6	50,25	S102	100LB	6	22000	9000
17,3	990	2,8	53,75	S122	100LB	6	30000	11200
17,2	966	1,7	81,39	S103	90LB ⁽¹⁾	4	22000	9000
17,1	1000	1,1	54,27	S082	100LB	6	18000	7200
17,1	969	1,0	81,71	S083	90LB ⁽¹⁾	4	18000	7200
16,9	1016	1,3	55,14	S102	100LB	6	22000	9000
15,7	1094	1,5	59,40	S102	100LB	6	22000	9000
15,6	1065	1,5	89,77	S103	90LB ⁽¹⁾	4	22000	9000
15,3	1085	0,9	91,49	S083	90LB ⁽¹⁾	4	18000	7200
15,0	1142	0,9	61,98	S082	100LB	6	18000	7200
14,3	1169	2,4	64,84	S123	100LB	6	30000	11200
14,1	1216	2,6	66,00	S122	100LB	6	30000	11200
14,0	1188	1,3	100,15	S103	90LB ⁽¹⁾	4	22000	9000
13,7	1250	1,3	67,84	S102	100LB	6	22000	9000
13,1	1282	2,2	71,07	S123	100LB	6	30000	11200
12,7	1311	1,2	110,55	S103	90LB ⁽¹⁾	4	22000	9000
12,5	1338	1,3	74,18	S103	100LB	6	22000	9000
12,4	1335	2,2	112,52	S123	90LB ⁽¹⁾	4	30000	11200
11,9	1415	2,2	78,46	S123	100LB	6	30000	11200
11,7	1433	3,1	79,45	S143	100LB	6	35000	18500
11,5	1439	1,1	121,29	S103	90LB ⁽¹⁾	4	22000	9000
11,4	1468	1,1	81,39	S103	100LB	6	22000	9000
11,4	1463	2,1	123,33	S123	90LB ⁽¹⁾	4	30000	11200
10,9	1527	1,0	128,73	S103	90LB ⁽¹⁾	4	22000	9000
10,8	1543	1,9	130,04	S123	90LB ⁽¹⁾	4	30000	11200
10,7	1574	2,0	87,27	S123	100LB	6	30000	11200
10,5	1587	1,9	133,78	S123	90LB ⁽¹⁾	4	30000	11200
10,4	1619	1,0	89,77	S103	100LB	6	22000	9000
9,9	1675	1,0	141,24	S103	90LB ⁽¹⁾	4	22000	9000
9,4	1782	2,6	98,81	S143	100LB	6	35000	18500
9,3	1806	0,9	100,15	S103	100LB	6	22000	9000
9,2	1796	1,7	151,43	S123	90LB ⁽¹⁾	4	30000	11200
8,8	1910	1,6	105,91	S123	100LB	6	30000	11200
8,5	1985	2,5	110,05	S143	100LB	6	35000	18500
8,3	2029	1,6	112,52	S123	100LB	6	30000	11200
7,9	2106	1,4	177,53	S123	90LB ⁽¹⁾	4	30000	11200
7,5	2224	1,4	123,33	S123	100LB	6	30000	11200
7,5	2226	2,2	123,44	S143	100LB	6	35000	18500
7,2	2345	1,3	130,04	S123	100LB	6	30000	11200

⁽¹⁾ Available only with brake motor (TBS)

1,85 kW

n2 [rpm]	M2 [Nm]	fs	i	Gear reducer	Size	Motor Pole	Fr2 D [N]	Fr2 C-L [N]
7,2	2308	1,3	194,59	S123	90LB ⁽¹⁾	4	30000	11200
7,0	2413	1,3	133,78	S123	100LB	6	30000	11200
6,7	2519	2,0	139,64	S143	100LB	6	35000	18500
6,5	2558	1,2	215,60	S123	90LB ⁽¹⁾	4	30000	11200
6,2	2689	1,9	149,10	S143	100LB	6	35000	18500
6,1	2731	1,2	151,43	S123	100LB	6	30000	11200
5,9	2834	1,1	238,93	S123	90LB ⁽¹⁾	4	30000	11200
5,9	2840	1,4	157,49	S143	100LB	6	35000	18500
5,5	3031	1,0	255,54	S123	90LB ⁽¹⁾	4	30000	11200
5,4	3094	1,6	171,55	S143	100LB	6	35000	18500
5,3	3164	1,4	175,41	S143	100LB	6	35000	18500
5,2	3202	1,0	177,53	S123	100LB	6	30000	11200
5,0	3323	0,9	280,10	S123	90LB ⁽¹⁾	4	30000	11200
4,7	3548	1,4	196,74	S143	100LB	6	35000	18500
4,2	4014	1,2	222,57	S143	100LB	6	35000	18500
3,9	4286	1,2	237,63	S143	100LB	6	35000	18500
3,4	4931	1,0	273,41	S143	100LB	6	35000	18500

2,20 kW

n2 [rpm]	M2 [Nm]	fs	i	Gear reducer	Size	Motor Pole	Fr2 D [N]	Fr2 C-L [N]
331,6	59	2,2	8,63	S052	90L	2	3106	3106
270,5	72	3,8	10,65	S062	90L	2	5881	2353
256,7	76	1,9	11,14	S052	90L	2	3310	3310
244,3	80	3,7	11,71	S062	90L	2	6050	2420
238,3	82	1,8	12,00	S052	90L	2	3369	3369
219,0	89	3,5	13,06	S062	90L	2	6232	2493
214,1	91	3,5	13,36	S062	90L	2	6270	2508
209,4	93	1,7	13,66	S052	90L	2	3471	3471
187,3	104	1,7	15,27	S052	90L	2	3558	3558
180,7	108	3,1	15,94	S062	90L	2	6557	2623
177,5	114	2,9	8,00	S062	100LA/112MR	4	6563	2625
176,9	110	3,1	16,16	S062	90L	2	6593	2637
175,6	111	1,6	16,29	S052	90L	2	3607	3607
164,6	123	1,4	8,63	S052	100LA/112MR	4	3631	3631
159,2	127	2,6	8,92	S062	100LA/112MR	4	6747	2699
153,5	127	1,4	18,63	S052	90L	2	3708	3708
148,8	136	2,7	9,55	S062	100LA/112MR	4	6861	2744
148,3	131	2,6	19,29	S062	90L	2	6896	2758
146,3	133	2,6	19,55	S062	90L	2	6920	2768
145,0	134	1,3	19,73	S052	90L	2	3749	3749
136,0	143	1,4	21,04	S052	90L	2	3794	3794

⁽¹⁾ Available only with brake motor (TBS)

2,20 kW

n2 [rpm]	M2 [Nm]	fs	i	Gear reducer	Motor Size	Pole	Fr2 D [N]	Fr2 C-L [N]
133,4	151	2,4	10,65	S062	100LA/112MR	4	7045	2818
132,8	147	1,3	21,53	S052	90L	2	3810	3810
129,3	151	4,0	22,13	S082	90L ⁽¹⁾	2	15239	4354
127,5	158	1,2	11,14	S052	100LA/112MR	4	3806	3806
126,7	161	3,6	7,34	S082	112M/112MA	6	15309	4374
123,4	158	2,2	23,18	S062	90L	2	7212	2885
121,3	166	2,3	11,71	S062	100LA/112MR	4	7204	2882
120,4	162	2,2	23,75	S062	90L	2	7253	2901
119,2	163	3,7	24,00	S082	90L	2	15625	4464
118,8	164	1,2	24,07	S052	90L	2	3884	3884
118,3	170	1,2	12,00	S052	100LA/112MR	4	3852	3852
116,3	175	2,0	8,00	S062	112M/112MA	6	7264	2906
115,3	177	3,6	8,06	S082	112M/112MA	6	15756	4502
113,8	171	2,1	25,14	S062	90L	2	7350	2940
113,5	171	1,3	25,20	S052	90L	2	3914	3914
110,9	175	1,2	25,79	S052	90L	2	3928	3928
109,8	177	3,4	26,05	S082	90L	2	16022	4578
108,7	185	2,3	13,06	S062	100LA/112MR	4	7386	2954
107,8	189	0,9	8,63	S052	112M/112MA	6	3896	3896
106,3	190	2,2	13,36	S062	100LA/112MR	4	7423	2969
104,8	186	3,6	27,29	S082	90L	2	16251	4643
104,2	195	1,8	8,92	S062	112M/112MA	6	7443	2977
104,0	194	1,1	13,66	S052	100LA/112MR	4	3927	3927
103,4	188	1,9	27,66	S062	90L	2	7511	3005
102,8	189	1,1	27,81	S052	90L	2	3973	3973
101,1	199	3,8	14,04	S082	100LA/112MR	4	16407	4688
99,7	195	3,5	28,67	S082	90L	2	16498	4714
97,4	209	1,8	9,55	S062	112M/112MA	6	7552	3021
96,6	201	3,4	29,60	S082	90L	2	16658	4759
95,3	204	1,1	30,00	S052	90L	2	4015	4015
95,3	204	1,8	30,00	S062	90L	2	7647	3059
93,5	218	3,1	9,94	S082	112M/112MA	6	16791	4797
93,0	217	1,1	15,27	S052	100LA/112MR	4	3984	3984
92,0	219	3,5	15,43	S082	100LA/112MR	4	16880	4823
90,3	223	3,4	15,73	S082	100LA/112MR	4	16977	4851
90,0	216	3,5	31,78	S082	90L	2	17019	4863
89,1	226	2,0	15,94	S062	100LA/112MR	4	7708	3083
87,9	222	1,0	32,55	S052	90L	2	4056	4056
87,9	230	2,0	16,16	S062	100LA/112MR	4	7730	3092
87,4	233	1,6	10,65	S062	112M/112MA	6	7725	3090
87,2	231	1,0	16,29	S052	100LA/112MR	4	4012	4012
86,7	225	1,0	33,00	S052	90L	2	4062	4062

⁽¹⁾ Available only with brake motor (TBS)

2,20 kW

n2 [rpm]	M2 [Nm]	fs	i	Gear reducer	Motor Size	Pole	Fr2 D [N]	Fr2 C-L [N]
85,2	224	2,0	33,57	S063	90L	2	7861	3144
84,3	231	1,8	33,93	S062	90L	2	7848	3139
82,1	246	3,1	17,29	S082	100LA/112MR	4	17469	4991
81,9	238	3,2	34,91	S082	90L	2	17508	5002
80,6	242	3,1	35,50	S082	90L	2	17597	5028
80,1	254	2,9	11,61	S082	112M/112MA	6	17588	5025
79,4	256	1,6	11,71	S062	112M/112MA	6	7871	3148
78,8	247	1,0	36,55	S052	90L	2	4103	4103
78,4	243	1,1	36,50	S053	90L	2	4135	4135
78,2	249	1,8	36,57	S062	90L	2	7968	3187
76,2	265	0,9	18,63	S052	100LA/112MR	4	4062	4062
75,7	252	1,8	37,77	S063	90L	2	8052	3221
74,6	270	2,8	19,03	S082	100LA/112MR	4	17973	5135
73,6	274	1,6	19,29	S062	100LA/112MR	4	8001	3200
72,9	279	2,8	12,75	S082	112M/112MA	6	18000	5167
72,9	279	3,8	12,75	S102	112M/112MA	6	22000	6400
72,6	278	1,7	19,55	S062	100LA/112MR	4	8021	3208
72,6	268	1,7	39,38	S062	90L	2	8082	3233
71,4	267	1,7	40,05	S063	90L	2	8144	3258
71,4	273	2,8	40,05	S082	90L	2	18000	5212
71,2	286	1,5	13,06	S062	112M/112MA	6	8031	3213
70,5	286	2,7	20,14	S082	100LA/112MR	4	18000	5222
69,6	293	1,5	13,36	S062	112M/112MA	6	8064	3225
67,3	289	3,6	42,53	S102	90L	2	22000	6572
66,4	293	2,6	43,05	S082	90L	2	18000	5325
66,2	308	2,6	14,04	S082	112M/112MA	6	18000	5317
65,5	297	1,5	43,64	S062	90L	2	8236	3294
65,0	299	3,3	44,00	S102	90L	2	22000	6641
64,2	314	2,5	22,13	S082	100LA/112MR	4	18000	5369
62,0	314	1,4	46,10	S062	90L	2	8314	3326
61,3	329	1,4	23,18	S062	100LA/112MR	4	8259	3304
60,7	321	3,7	47,13	S102	90L	2	22000	6783
60,3	338	2,4	15,43	S082	112M/112MA	6	18000	5465
60,3	338	3,9	15,43	S102	112MA	6	22000	6786
59,8	337	1,4	23,75	S062	100LA/112MR	4	8291	3316
59,2	329	1,4	48,30	S062	90L	2	8379	3352
59,2	341	2,3	24,00	S082	100LA/112MR	4	18000	5498
59,1	344	2,3	15,73	S082	112M/112MA	6	18000	5495
58,4	349	1,4	15,94	S062	112M/112MA	6	8301	3320
58,2	327	1,4	49,13	S063	90L	2	8447	3379
57,5	354	1,3	16,16	S062	112M/112MA	6	8318	3327
56,9	342	2,2	50,25	S082	90L	2	18000	5572

2,20 kW

n2 [rpm]	M2 [Nm]	fs	i	Gear reducer	Motor Size	Pole	Fr2 D [N]	Fr2 C-L [N]
56,9	342	3,1	50,25	S102	90L	2	22000	6917
56,5	357	1,3	25,14	S062	100LA/112MR	4	8364	3346
54,5	370	2,2	26,05	S082	100LA/112MR	4	18000	5630
54,0	377	3,6	17,21	S102	112M/112MA	6	22000	7016
53,8	379	2,1	17,29	S082	112M/112MA	6	18000	5649
53,4	364	1,2	53,53	S062	90L	2	8515	3406
52,7	369	2,0	54,27	S082	90L	2	18000	5698
52,0	374	1,2	55,00	S062	90L	2	8549	3419
52,0	388	2,3	27,29	S082	100LA/112MR	4	18000	5706
51,9	375	2,6	55,14	S102	90L	2	22000	7116
51,7	368	1,2	55,29	S063	90L	2	8605	3442
51,3	393	1,2	27,66	S062	100LA/112MR	4	8477	3391
49,5	407	2,2	28,67	S082	100LA/112MR	4	18000	5787
48,9	417	1,9	19,03	S082	112M/112MA	6	18000	5805
48,9	416	3,5	19,00	S102	112M/112MA	6	22000	7228
48,7	391	1,2	58,72	S063	90L	2	8679	3472
48,2	422	1,1	19,29	S062	112M/112MA	6	8519	3407
48,1	404	3,0	59,40	S102	90L	2	22000	7278
48,0	420	2,1	29,60	S082	100LA/112MR	4	18000	5840
47,6	428	1,1	19,55	S062	112M/112MA	6	8532	3413
47,5	424	3,5	29,87	S102	100LA/112MR	4	22000	7295
47,3	426	1,2	30,00	S062	100LA/112MR	4	8564	3426
46,2	441	1,8	20,14	S082	112M/112MA	6	18000	5900
46,1	422	1,8	61,98	S082	90L	2	18000	5919
44,7	451	2,2	31,78	S082	100LA/112MR	4	18000	5959
44,7	456	3,2	20,83	S102	112M/112MA	6	22000	7431
43,8	460	3,3	32,40	S102	100LA/112MR	4	22000	7476
43,4	439	1,0	65,85	S063	90L	2	8808	3523
42,4	450	1,7	67,52	S083	90L	2	18000	6074
42,2	462	2,6	67,84	S102	90L	2	22000	7575
42,0	485	1,7	22,13	S082	112M/112MA	6	18000	6058
42,0	485	3,0	22,13	S102	112M/112MA	6	22000	7566
41,9	482	1,1	33,93	S062	100LA/112MR	4	8677	3471
40,7	496	2,0	34,91	S082	100LA/112MR	4	18000	6118
40,7	496	2,8	34,91	S102	100LA/112MR	4	22000	7644
40,1	508	1,0	23,18	S062	112M/112MA	6	8679	3471
40,0	504	2,0	35,50	S082	100LA/112MR	4	18000	6147
39,2	520	0,9	23,75	S062	112M/112MA	6	8695	3478
38,8	519	1,2	36,57	S062	100LA/112MR	4	8734	3493
38,8	526	1,6	24,00	S082	112M/112MA	6	18000	6196
38,6	494	1,5	74,18	S083	90L	2	18000	6237
38,6	494	2,4	74,18	S103	90L	2	22000	7788

2,20 kW

n2 [rpm]	M2 [Nm]	fs	i	Gear reducer	Motor Size	Pole	Fr2 D [N]	Fr2 C-L [N]
38,3	532	3,0	24,28	S102	112M/112MA	6	22000	7777
37,1	544	2,8	38,30	S102	100LA/112MR	4	22000	7857
37,0	551	0,9	25,14	S062	112M/112MA	6	8729	3492
36,1	559	1,1	39,38	S062	100LA/112MR	4	8778	3511
35,7	571	1,5	26,05	S082	112M/112MA	6	18000	6337
35,5	569	1,8	40,05	S082	100LA/112MR	4	18000	6355
35,3	577	2,7	26,33	S102	112M/112MA	6	22000	7966
35,1	542	2,2	81,39	S103	90L	2	22000	8006
35,0	544	1,4	81,71	S083	90L	2	18000	6407
34,1	598	1,6	27,29	S082	112M/112MA	6	18000	6418
33,4	604	2,3	42,53	S102	100LA/112MR	4	22000	8103
33,0	612	1,6	43,05	S082	100LA/112MR	4	18000	6481
32,5	620	1,0	43,64	S062	100LA/112MR	4	8819	3528
32,4	628	1,5	28,67	S082	112M/112MA	6	18000	6505
32,3	625	2,1	44,00	S102	100LA/112MR	4	22000	8184
31,9	598	2,0	89,77	S103	90L	2	22000	8241
31,8	634	3,8	44,63	S122	100LA/112MR	4	30000	11200
31,4	648	1,5	29,60	S082	112M/112MA	6	18000	6561
31,3	610	1,2	91,49	S083	90L	2	18000	6609
31,1	654	2,4	29,87	S102	112M/112MA	6	22000	8265
30,1	669	2,4	47,13	S102	100LA/112MR	4	22000	8349
29,3	696	1,5	31,78	S082	112M/112MA	6	18000	6686
29,0	697	3,4	49,04	S122	100LA/112MR	4	30000	11200
28,7	710	2,2	32,40	S102	112M/112MA	6	22000	8462
28,6	667	1,8	100,15	S103	90L	2	22000	8509
28,4	671	1,1	100,62	S083	90L	2	18000	6781
28,3	714	1,4	50,25	S082	100LA/112MR	4	18000	6755
28,3	714	2,0	50,25	S102	100LA/112MR	4	22000	8506
26,6	765	1,4	34,91	S082	112M/112MA	6	18000	6853
26,6	765	1,9	34,91	S102	112M/112MA	6	22000	8645
26,4	763	3,4	53,75	S122	100LA/112MR	4	30000	11200
26,2	778	1,4	35,50	S082	112M/112MA	6	18000	6883
26,2	771	1,3	54,27	S082	100LA/112MR	4	18000	6892
25,9	737	1,6	110,55	S103	90L	2	22000	8756
25,8	783	1,7	55,14	S102	100LA/112MR	4	22000	8735
25,4	750	3,0	112,52	S123	90L	2	30000	11200
24,3	839	1,9	38,30	S102	112M/112MA	6	22000	8877
23,9	844	1,9	59,40	S102	100LA/112MR	4	22000	8922
23,6	808	1,5	121,29	S103	90L	2	22000	8992
23,2	877	1,2	40,05	S082	112M/112MA	6	18000	7098
23,2	822	2,7	123,33	S123	90L	2	30000	11200
22,9	880	1,1	61,98	S082	100LA/112MR	4	18000	7130

2,20 kW

n2 [rpm]	M2 [Nm]	fs	i	Gear reducer	Motor Size	Pole	Fr2 D [N]	Fr2 C-L [N]
22,6	900	3,5	41,07	S122	112M/112MA	6	30000	11200
22,2	858	1,4	128,73	S103	90L	2	22000	9000
22,0	867	2,6	130,04	S123	90L	2	30000	11200
21,9	931	1,6	42,53	S102	112M/112MA	6	22000	9000
21,9	902	3,0	64,84	S123	100LA/112MR	4	30000	11200
21,6	943	1,1	43,05	S082	112M/112MA	6	18000	7200
21,5	937	3,2	66,00	S122	100LA/112MR	4	30000	11200
21,4	891	2,5	133,78	S123	90L	2	30000	11200
21,3	955	3,3	43,60	S122	112M/112MA	6	30000	11200
21,1	964	1,4	44,00	S102	112M/112MA	6	22000	9000
21,0	939	1,1	67,52	S083	100LA/112MR	4	18000	7200
20,9	964	1,7	67,84	S102	100LA/112MR	4	22000	9000
20,8	978	2,6	44,63	S122	112M/112MA	6	30000	11200
20,2	941	1,3	141,24	S103	90L	2	22000	9000
20,0	988	2,7	71,07	S123	100LA/112MR	4	30000	11200
19,7	1032	1,6	47,13	S102	112M/112MA	6	22000	9000
19,1	1032	1,0	74,18	S083	100LA/112MR	4	18000	7200
19,1	1032	1,6	74,18	S103	100LA/112MR	4	22000	9000
19,0	1074	2,3	49,04	S122	112M/112MA	6	30000	11200
18,9	1009	2,2	151,43	S123	90L	2	30000	11200
18,5	1101	1,0	50,25	S082	112M/112MA	6	18000	7200
18,5	1101	1,3	50,25	S102	112M/112MA	6	22000	9000
18,1	1091	2,7	78,46	S123	100LA/112MR	4	30000	11200
17,9	1105	0,9	81,71	S083	112MR	4	18000	7200
17,9	1105	3,8	79,45	S143	100LA/112MR	4	35000	18500
17,7	1152	0,9	54,27	S082	112M	6	18000	7200
17,4	1132	1,4	81,39	S103	100LA/112MR	4	22000	9000
17,3	1177	2,3	53,75	S122	112M/112MA	6	30000	11200
16,9	1208	1,1	55,14	S102	112M/112MA	6	22000	9000
16,5	1158	1,0	173,78	S103	90L	2	22000	9000
16,3	1214	2,5	87,27	S123	100LA/112MR	4	30000	11200
16,1	1183	1,9	177,53	S123	90L	2	30000	11200
15,8	1248	1,3	89,77	S103	100LA/112MR	4	22000	9000
15,7	1301	1,3	59,40	S102	112M/112MA	6	22000	9000
14,7	1297	1,7	194,59	S123	90L	2	30000	11200
14,4	1387	3,6	64,68	S143	112M/112MA	6	35000	18500
14,4	1374	3,2	98,81	S143	100LA/112MR	4	35000	18500
14,3	1391	2,0	64,84	S123	112M/112MA	6	30000	11200
14,2	1393	1,1	100,15	S103	100LA/112MR	4	22000	9000
14,1	1446	2,2	66,00	S122	112M/112MA	6	30000	11200
13,7	1486	1,1	67,84	S102	112M/112MA	6	22000	9000
13,5	1481	3,5	69,06	S143	112M/112MA	6	35000	18500

2,20 kW

n2 [rpm]	M2 [Nm]	fs	i	Gear reducer	Motor Size	Pole	Fr2 D [N]	Fr2 C-L [N]
13,4	1473	2,0	105,91	S123	100LA/112MR	4	30000	11200
13,3	1437	1,6	215,60	S123	90L	2	30000	11200
13,1	1524	1,9	71,07	S123	112M/112MA	6	30000	11200
12,9	1531	3,1	110,05	S143	100LA/112MR	4	35000	18500
12,8	1537	1,0	110,55	S103	100LA/112MR	4	22000	9000
12,6	1565	1,9	112,52	S123	100LA/112MR	4	30000	11200
12,5	1591	1,1	74,18	S103	112M/112MA	6	22000	9000
12,0	1592	1,4	238,93	S123	90L	2	30000	11200
11,9	1683	1,9	78,46	S123	112M/112MA	6	30000	11200
11,7	1687	0,9	121,29	S103	100LA/112MR	4	22000	9000
11,7	1704	2,6	79,45	S143	112M/112MA	6	35000	18500
11,5	1715	1,7	123,33	S123	100LA/112MR	4	30000	11200
11,5	1717	2,8	123,44	S143	100LA/112MR	4	35000	18500
11,4	1746	1,0	81,39	S103	112M/112MA	6	22000	9000
11,2	1765	0,9	128,73	S103	100LA/112MR	4	22000	9000
11,2	1703	1,3	255,54	S123	90L	2	30000	11200
10,9	1809	1,7	130,04	S123	100LA/112MR	4	30000	11200
10,7	1865	0,9	89,77	S103	112M	6	22000	9000
10,7	1872	1,7	87,27	S123	112M/112MA	6	30000	11200
10,6	1861	1,6	133,78	S123	100LA/112MR	4	30000	11200
10,2	1866	1,2	280,10	S123	90L	2	30000	11200
10,2	1942	2,5	139,64	S143	100LA/112MR	4	35000	18500
9,5	2007	1,1	301,16	S123	90L	2	30000	11200
9,5	2074	2,3	149,10	S143	100LA/112MR	4	35000	18500
9,4	2106	1,4	151,43	S123	100LA/112MR	4	30000	11200
9,4	2119	2,2	98,81	S143	112M/112MA	6	35000	18500
9,0	2190	1,7	157,49	S143	100LA/112MR	4	35000	18500
8,8	2272	1,4	105,91	S123	112M/112MA	6	30000	11200
8,5	2360	2,1	110,05	S143	112M/112MA	6	35000	18500
8,3	2413	1,3	112,52	S123	112M/112MA	6	30000	11200
8,3	2386	2,0	171,55	S143	100LA/112MR	4	35000	18500
8,1	2440	1,7	175,41	S143	100LA/112MR	4	35000	18500
8,0	2469	1,2	177,53	S123	100LA/112MR	4	30000	11200
7,5	2645	1,2	123,33	S123	112M/112MA	6	30000	11200
7,5	2648	1,9	123,44	S143	112M/112MA	6	35000	18500
7,3	2706	1,1	194,59	S123	100LA/112MR	4	30000	11200
7,2	2789	1,1	130,04	S123	112M/112MA	6	30000	11200
7,2	2736	1,7	196,74	S143	100LA/112MR	4	35000	18500
7,0	2869	1,1	133,78	S123	112M/112MA	6	30000	11200
6,7	2995	1,7	139,64	S143	112M/112MA	6	35000	18500
6,6	2999	1,0	215,60	S123	100LA/112MR	4	30000	11200
6,4	3095	1,5	222,57	S143	100LA/112MR	4	35000	18500

2,20 kW

n2 [rpm]	M2 [Nm]	fs	i	Gear reducer	Motor Size	Pole	Fr2 D [N]	Fr2 C-L [N]
6,2	3198	1,6	149,10	S143	112M/112MA	6	35000	18500
6,1	3248	1,0	151,43	S123	112M/112MA	6	30000	11200
6,0	3305	1,5	237,63	S143	100LA/112MR	4	35000	18500
5,9	3323	0,9	238,93	S123	100LA/112MR	4	30000	11200
5,9	3378	1,2	157,49	S143	112M/112MA	6	35000	18500
5,4	3679	1,3	171,55	S143	112M/112MA	6	35000	18500
5,3	3762	1,2	175,41	S143	112M/112MA	6	35000	18500
5,2	3803	1,3	273,41	S143	100LA/112MR	4	35000	18500
4,7	4220	1,2	196,74	S143	112M/112MA	6	35000	18500
4,2	4774	1,0	222,57	S143	112M/112MA	6	35000	18500
3,9	5097	1,0	237,63	S143	112M/112MA	6	35000	18500

3,00 kW

n2 [rpm]	M2 [Nm]	fs	i	Gear reducer	Motor Size	Pole	Fr2 D [N]	Fr2 C-L [N]
358,8	74	3,3	8,00	S062	100L/100LA	2	5305	2122
332,8	80	1,6	8,63	S052	100L/100LA	2	2979	2979
321,7	83	3,0	8,92	S062	100L/100LA	2	5462	2185
300,7	88	3,1	9,55	S062	100L/100LA	2	5561	2224
269,6	98	2,7	10,65	S062	100L/100LA	2	5721	2288
257,6	103	1,4	11,14	S052	100L/100LA	2	3148	3148
245,1	108	2,7	11,71	S062	100L/100LA	2	5861	2344
239,2	111	1,4	12,00	S052	100L/100LA	2	3194	3194
219,8	121	2,6	13,06	S062	100L/100LA	2	6022	2409
214,9	124	2,6	13,36	S062	100L/100LA	2	6055	2422
210,2	126	1,2	13,66	S052	100L/100LA	2	3273	3273
193,5	142	3,9	7,34	S082	100LB/112MS	4	13306	3802
187,9	141	1,3	15,27	S052	100L/100LA	2	3337	3337
182,5	145	4,0	15,73	S082	100LA ⁽¹⁾	2	13563	3875
180,1	147	2,3	15,94	S062	100L/100LA	2	6314	2526
177,6	149	2,3	16,16	S062	100L/100LA	2	6335	2534
177,5	155	2,1	8,00	S062	100LB/112MS	4	6301	2520
176,2	151	1,2	16,29	S052	100L/100LA	2	3371	3371
176,1	156	3,8	8,06	S082	100LB/112MS	4	13694	3912
165,9	160	3,6	17,29	S082	100L/100LA	2	13963	3989
164,6	167	1,0	8,63	S052	100LB/112MS	4	3372	3372
159,2	173	1,9	8,92	S062	100LB/112MS	4	6455	2582
154,0	172	1,0	18,63	S052	100L/100LA	2	3438	3438
150,8	176	3,3	19,03	S082	100L/100LA	2	14374	4107
148,8	185	1,9	9,55	S062	100LB/112MS	4	6548	2619
148,8	178	1,9	19,29	S062	100L/100LA	2	6589	2635
146,8	181	1,9	19,55	S062	100L/100LA	2	6608	2643

⁽¹⁾ Available only with brake motor (TBS)

3,00 kW

n2 [rpm]	M2 [Nm]	fs	i	Gear reducer	Motor Size	Pole	Fr2 D [N]	Fr2 C-L [N]
142,8	193	3,4	9,94	S082	100LB/112MS	4	14592	4169
142,5	186	3,1	20,14	S082	100L/100LA	2	14623	4178
136,4	195	1,0	21,04	S052	100L/100LA	2	3490	3490
133,4	206	1,7	10,65	S062	100LB/112MS	4	6696	2678
129,7	205	2,9	22,13	S082	100L/100LA	2	15043	4298
126,7	219	2,6	7,34	S082	112MB/132S/132SA	6	15117	4319
123,8	214	1,6	23,18	S062	100L/100LA	2	6843	2737
122,4	225	3,1	11,61	S082	100LB/112MS	4	15283	4367
121,3	227	1,7	11,71	S062	100LB/112MS	4	6821	2728
120,8	220	1,6	23,75	S062	100L/100LA	2	6876	2750
119,6	222	2,7	24,00	S082	100L/100LA	2	15414	4404
116,3	239	1,5	8,00	S062	112MB	6	6860	2744
115,3	241	2,6	8,06	S082	112MB/132S/132SA	6	15545	4441
115,3	241	3,7	8,06	S102	112MB/132S/132SA	6	19255	5501
114,1	233	1,5	25,14	S062	100L/100LA	2	6951	2781
111,4	247	3,0	12,75	S082	100LB/112MS	4	15715	4490
110,2	241	2,5	26,05	S082	100L/100LA	2	15794	4512
108,7	253	1,7	13,06	S062	100LB/112MS	4	6958	2783
106,3	259	1,6	13,36	S062	100LB/112MS	4	6985	2794
105,2	252	2,7	27,29	S082	100L/100LA	2	16012	4575
105,1	264	3,6	8,85	S102	112MB/132S/132SA	6	19812	5661
104,2	266	1,3	8,92	S062	112MB	6	6992	2797
103,8	256	1,4	27,66	S062	100L/100LA	2	7073	2829
101,1	272	2,8	14,04	S082	100LB/112MS	4	16168	4620
100,1	265	2,5	28,67	S082	100L/100LA	2	16248	4642
97,4	285	1,3	9,55	S062	112MB	6	7070	2828
97,0	274	2,5	29,60	S082	100L/100LA	2	16400	4686
95,7	277	1,4	30,00	S062	100L/100LA	2	7172	2869
93,5	297	2,3	9,94	S082	112MB/132S/132SA	6	16531	4723
92,0	299	2,6	15,43	S082	100LB/112MS	4	16618	4748
90,3	305	2,5	15,73	S082	100LB/112MS	4	16710	4774
90,3	294	2,6	31,78	S082	100L/100LA	2	16744	4784
89,1	309	1,5	15,94	S062	100LB/112MS	4	7186	2875
88,6	300	3,8	32,40	S102	100L/100LA	2	20912	5975
87,9	313	1,4	16,16	S062	100LB/112MS	4	7201	2880
87,4	318	1,2	10,65	S062	112MB	6	7187	2875
85,4	325	3,1	10,88	S102	112MB/132S/132SA	6	21106	6030
84,6	314	1,3	33,93	S062	100L/100LA	2	7312	2925
82,5	333	3,9	17,21	S102	100LB/112MS	4	21340	6097
82,2	323	2,3	34,91	S082	100L/100LA	2	17207	4916
82,2	323	3,3	34,91	S102	100L/100LA	2	21392	6112
82,1	335	2,3	17,29	S082	100LB/112MS	4	17175	4907

3,00 kW

n2 [rpm]	M2 [Nm]	fs	i	Gear reducer	Motor Size	Pole	Fr2 D [N]	Fr2 C-L [N]
80,8	328	2,3	35,50	S082	100L/100LA	2	17291	4940
80,1	347	2,1	11,61	S082	112MB/132S/132SA	6	17284	4938
79,4	350	1,2	11,71	S062	112MB	6	7280	2912
78,5	338	1,3	36,57	S062	100L/100LA	2	7390	2956
74,9	354	3,2	38,30	S102	100L/100LA	2	22000	6286
74,7	368	3,8	19,00	S102	100LB/112MS	4	21986	6282
74,6	369	2,1	19,03	S082	100LB/112MS	4	17650	5043
73,6	374	1,2	19,29	S062	100LB/112MS	4	7369	2948
72,9	364	1,2	39,38	S062	100L/100LA	2	7461	2985
72,9	381	2,1	12,75	S082	112MB/132S/132SA	6	17752	5072
72,9	381	2,8	12,75	S102	112MB/132S/132SA	6	22000	6325
72,6	379	1,2	19,55	S062	100LB/112MS	4	7381	2952
71,7	370	2,0	40,05	S082	100L/100LA	2	17898	5114
71,2	390	1,1	13,06	S062	112MB	6	7372	2949
70,5	390	2,0	20,14	S082	100LB/112MS	4	17936	5125
69,6	399	1,1	13,36	S062	112MB	6	7389	2956
68,2	403	3,5	20,83	S102	100LB/112MS	4	22000	6457
67,5	393	2,7	42,53	S102	100L/100LA	2	22000	6487
66,7	398	1,9	43,05	S082	100L/100LA	2	18000	5220
66,5	418	3,0	13,99	S102	112MB/132S/132SA	6	22000	6503
66,2	419	1,9	14,04	S082	112MB/132S/132SA	6	18000	5212
65,8	404	1,1	43,64	S062	100L/100LA	2	7549	3019
65,2	407	2,4	44,00	S102	100L/100LA	2	22000	6554
64,2	429	1,9	22,13	S082	100LB/112MS	4	18000	5261
64,2	429	3,3	22,13	S102	100LB/112MS	4	22000	6575
61,3	449	1,0	23,18	S062	100LB/112MS	4	7500	3000
60,9	436	2,8	47,13	S102	100L/100LA	2	22000	6690
60,3	461	1,8	15,43	S082	112MB/132S/132SA	6	18000	5350
60,3	461	2,8	15,43	S102	112MB/132S/132SA	6	22000	6695
59,8	460	1,0	23,75	S062	100LB/112MS	4	7514	3005
59,4	447	1,0	48,30	S062	100L/100LA	2	7620	3048
59,2	465	1,7	24,00	S082	100LB/112MS	4	18000	5381
59,1	470	1,7	15,73	S082	112MB/132S/132SA	6	18000	5378
58,5	470	3,2	24,28	S102	100LB/112MS	4	22000	6758
58,5	454	4,0	49,04	S122	100LA ⁽¹⁾	2	30000	9674
58,4	476	1,0	15,94	S062	112MB	6	7496	2998
57,5	483	1,0	16,16	S062	112MB	6	7502	3001
57,1	465	1,6	50,25	S082	100L/100LA	2	18000	5450
57,1	465	2,3	50,25	S102	100L/100LA	2	22000	6818
56,5	487	1,0	25,14	S062	100LB/112MS	4	7541	3016
54,5	505	1,6	26,05	S082	100LB/112MS	4	18000	5504
54,0	514	2,7	17,21	S102	112MB/132S/132SA	6	22000	6914

⁽¹⁾ Available only with brake motor (TBS)

3,00 kW

n2 [rpm]	M2 [Nm]	fs	i	Gear reducer	Motor Size	Pole	Fr2 D [N]	Fr2 C-L [N]
53,9	510	2,9	26,33	S102	100LB/112MS	4	22000	6922
53,8	517	1,6	17,29	S082	112MB/132S/132SA	6	18000	5519
53,4	497	3,9	53,75	S122	100L/100LA	2	30000	9940
52,9	502	1,5	54,27	S082	100L/100LA	2	18000	5566
52,1	510	1,9	55,14	S102	100L/100LA	2	22000	7007
52,0	529	1,7	27,29	S082	100LB/112MS	4	18000	5573
51,7	532	0,9	27,66	S062	100LB/112MS	4	7570	3028
49,5	555	1,6	28,67	S082	100LB/112MS	4	18000	5648
48,9	568	1,4	19,03	S082	112MB/132S/132SA	6	18000	5663
48,9	568	2,6	19,00	S102	112MB/132S/132SA	6	22000	7116
48,3	549	2,2	59,40	S102	100L/100LA	2	22000	7162
48,0	573	1,6	29,60	S082	100LB/112MS	4	18000	5697
47,5	579	2,6	29,87	S102	100LB/112MS	4	22000	7181
46,3	573	1,3	61,98	S082	100L/100LA	2	18000	5770
46,2	602	1,3	20,14	S082	112MB/132S/132SA	6	18000	5749
44,7	615	1,6	31,78	S082	100LB/112MS	4	18000	5805
44,7	622	2,4	20,83	S102	112MB/132S/132SA	6	22000	7308
44,3	587	3,4	64,84	S123	100L/100LA	2	30000	10511
43,8	628	2,4	32,40	S102	100LB/112MS	4	22000	7352
43,5	610	3,7	66,00	S122	100L/100LA	2	30000	10551
43,2	644	3,9	22,24	S142	132S/132SA	6	35000	18500
42,5	611	1,2	67,52	S083	100L/100LA	2	18000	5915
42,3	627	1,9	67,84	S102	100L/100LA	2	22000	7443
42,0	661	1,3	22,13	S082	112MB/132S/132SA	6	18000	5892
42,0	661	2,2	22,13	S102	112MB/132S/132SA	6	22000	7435
40,7	676	1,5	34,91	S082	100LB/112MS	4	18000	5949
40,7	676	2,1	34,91	S102	100LB/112MS	4	22000	7510
40,4	644	3,1	71,07	S123	100L/100LA	2	30000	10793
40,0	688	1,5	35,50	S082	100LB/112MS	4	18000	5975
38,8	717	1,2	24,00	S082	112MB/132S/132SA	6	18000	6017
38,7	672	1,1	74,18	S083	100L/100LA	2	18000	6063
38,7	672	1,8	74,18	S103	100L/100LA	2	22000	7647
38,3	725	2,2	24,28	S102	112MB/132S/132SA	6	22000	7634
38,0	731	3,0	25,26	S142	132S/132SA	6	35000	18500
37,1	742	2,0	38,30	S102	100LB/112MS	4	22000	7711
36,6	710	3,2	78,46	S123	100L/100LA	2	30000	11102
35,7	778	1,1	26,05	S082	112MB/132S/132SA	6	18000	6143
35,5	776	1,3	40,05	S082	100LB/112MS	4	18000	6161
35,3	787	2,0	26,33	S102	112MB/132S/132SA	6	22000	7811
35,3	737	1,6	81,39	S103	100L/100LA	2	22000	7852
35,1	740	1,0	81,71	S083	100L/100LA	2	18000	6216
34,6	795	3,8	41,07	S122	100LB/112MS	4	30000	11200

3,00 kW

n2 [rpm]	M2 [Nm]	fs	i	Gear reducer	Motor Size	Pole	Fr2 D [N]	Fr2 C-L [N]
34,1	815	1,2	27,29	S082	112MB/132S/132SA	6	18000	6214
33,9	820	3,0	28,33	S142	132S/132SA	6	35000	18500
33,4	824	1,7	42,53	S102	100LB/112MS	4	22000	7940
33,0	834	1,2	43,05	S082	100LB/112MS	4	18000	6273
32,9	790	2,8	87,27	S123	100L/100LA	2	30000	11200
32,6	844	3,6	43,60	S122	100LB/112MS	4	30000	11200
32,5	854	3,7	28,60	S122	112MB/132S/132SA	6	30000	11200
32,4	856	1,1	28,67	S082	112MB/132S/132SA	6	18000	6290
32,3	852	1,5	44,00	S102	100LB/112MS	4	22000	8016
32,0	813	1,5	89,77	S103	100L/100LA	2	22000	8072
31,8	864	2,8	44,63	S122	100LB/112MS	4	30000	11200
31,4	884	1,1	29,60	S082	112MB/132S/132SA	6	18000	6339
31,1	892	1,8	29,87	S102	112MB/132S/132SA	6	22000	8089
30,5	911	3,5	30,51	S122	112MB/132S/132SA	6	30000	11200
30,1	913	1,8	47,13	S102	100LB/112MS	4	22000	8169
30,0	927	3,0	32,05	S142	132S/132SA	6	35000	18500
29,3	949	1,1	31,78	S082	112MB/132S/132SA	6	18000	6448
29,0	950	2,5	49,04	S122	100LB/112MS	4	30000	11200
28,7	968	1,6	32,40	S102	112MB/132S/132SA	6	22000	8271
28,7	907	1,3	100,15	S103	100L/100LA	2	22000	8321
28,4	978	3,2	32,76	S122	112MB/132S/132SA	6	30000	11200
28,3	973	1,0	50,25	S082	100LB/112MS	4	18000	6511
28,3	973	1,4	50,25	S102	100LB/112MS	4	22000	8313
28,1	990	3,0	34,22	S142	132S/132SA	6	35000	18500
27,8	999	3,2	33,44	S122	112MB/132S/132SA	6	30000	11200
27,1	959	2,3	105,91	S123	100L/100LA	2	30000	11200
26,6	1043	1,0	34,91	S082	112MB/132S/132SA	6	18000	6592
26,6	1043	1,4	34,91	S102	112MB/132S/132SA	6	22000	8439
26,4	1051	3,0	35,20	S122	112MB/132S/132SA	6	30000	11200
26,4	1041	2,5	53,75	S122	100LB/112MS	4	30000	11200
26,2	1060	1,0	35,50	S082	112MB	6	18000	6617
26,2	1051	1,0	54,27	S082	100LB/112MS	4	18000	6629
26,0	1001	1,2	110,55	S103	100L/100LA	2	22000	8549
25,8	1068	1,2	55,14	S102	100LB/112MS	4	22000	8524
25,5	1019	2,2	112,52	S123	100L/100LA	2	30000	11200
24,3	1144	1,4	38,30	S102	112MB/132S/132SA	6	22000	8651
23,9	1151	1,4	59,40	S102	100LB/112MS	4	22000	8695
23,7	1098	1,1	121,29	S103	100L/100LA	2	22000	8766
23,3	1117	2,0	123,33	S123	100L/100LA	2	30000	11200
22,6	1227	2,6	41,07	S122	112MB/132S/132SA	6	30000	11200
22,3	1166	1,0	128,73	S103	100L/100LA	2	22000	8906
22,1	1178	1,9	130,04	S123	100L/100LA	2	30000	11200

3,00 kW

n2 [rpm]	M2 [Nm]	fs	i	Gear reducer	Motor Size	Pole	Fr2 D [N]	Fr2 C-L [N]
22,0	1227	3,9	64,68	S143	100LB/112MS	4	35000	18500
21,9	1270	1,2	42,53	S102	112MB/132S/132SA	6	22000	8891
21,9	1230	2,2	64,84	S123	100LB/112MS	4	30000	11200
21,5	1278	2,3	66,00	S122	100LB/112MS	4	30000	11200
21,5	1211	1,9	133,78	S123	100L/100LA	2	30000	11200
21,3	1302	2,4	43,60	S122	112MB/132S/132SA	6	30000	11200
21,1	1314	1,0	44,00	S102	112MB	6	22000	8969
20,9	1314	1,2	67,84	S102	100LB/112MS	4	22000	9000
20,8	1333	1,9	44,63	S122	112MB/132S/132SA	6	30000	11200
20,6	1310	3,7	69,06	S143	100LB/112MS	4	35000	18500
20,3	1339	3,1	45,77	S143	112MB/132S/132SA	6	35000	18500
20,0	1348	2,0	71,07	S123	100LB/112MS	4	30000	11200
19,7	1408	1,2	47,13	S102	112MB/132S/132SA	6	22000	9000
19,1	1407	1,1	74,18	S103	100LB/112MS	4	22000	9000
19,0	1465	1,7	49,04	S122	112MB/132S/132SA	6	30000	11200
19,0	1371	1,6	151,43	S123	100L/100LA	2	30000	11200
18,5	1501	1,0	50,25	S102	112MB	6	22000	9000
18,2	1491	3,1	50,97	S143	112MB/132S/132SA	6	35000	18500
18,1	1488	2,0	78,46	S123	100LB/112MS	4	30000	11200
17,9	1507	2,8	79,45	S143	100LB/112MS	4	35000	18500
17,4	1544	1,0	81,39	S103	100LB/112MS	4	22000	9000
17,3	1606	1,7	53,75	S122	112MB/132S/132SA	6	30000	11200
16,3	1655	1,8	87,27	S123	100LB/112MS	4	30000	11200
16,3	1672	3,0	57,17	S143	112MB/132S/132SA	6	35000	18500
16,2	1608	1,4	177,53	S123	100L/100LA	2	30000	11200
15,8	1702	0,9	89,77	S103	100LB/112MS	4	22000	9000
15,7	1774	0,9	59,40	S102	112MB	6	22000	9000
14,7	1762	1,3	194,59	S123	100L/100LA	2	30000	11200
14,4	1892	2,7	64,68	S143	112MB/132S/132SA	6	35000	18500
14,4	1874	2,4	98,81	S143	100LB/112MS	4	35000	18500
14,3	1896	1,5	64,84	S123	112MB/132S/132SA	6	30000	11200
14,1	1971	1,6	66,00	S122	112MB/132S/132SA	6	30000	11200
13,5	2020	2,5	69,06	S143	112MB/132S/132SA	6	35000	18500
13,4	2009	1,5	105,91	S123	100LB/112MS	4	30000	11200
13,3	1952	1,2	215,60	S123	100L/100LA	2	30000	11200
13,1	2079	1,4	71,07	S123	112MB/132S/132SA	6	30000	11200
13,0	2086	3,9	73,63	S153	132S/132SA	6	40000	19400
12,9	2087	2,3	110,05	S143	100LB/112MS	4	35000	18500
12,6	2134	1,4	112,52	S123	100LB/112MS	4	30000	11200
12,0	2164	1,0	238,93	S123	100L/100LA	2	30000	11200
11,9	2295	1,4	78,46	S123	112MB/132S/132SA	6	30000	11200
11,7	2324	1,9	79,45	S143	112MB/132S/132SA	6	35000	18500

3,00 kW

n2 [rpm]	M2 [Nm]	fs	i	Gear reducer	Motor Size	Pole	Fr2 D [N]	Fr2 C-L [N]
11,5	2339	1,3	123,33	S123	100LB/112MS	4	30000	11200
11,5	2341	2,0	123,44	S143	100LB/112MS	4	35000	18500
11,0	2470	3,0	87,16	S153	132S/132SA	6	40000	19400
10,9	2466	1,2	130,04	S123	100LB/112MS	4	30000	11200
10,7	2552	1,2	87,27	S123	112MB/132S/132SA	6	30000	11200
10,6	2537	1,2	133,78	S123	100LB/112MS	4	30000	11200
10,2	2648	1,8	139,64	S143	100LB/112MS	4	35000	18500
9,9	2756	3,0	97,27	S153	132S/132SA	6	40000	19400
9,5	2828	1,7	149,10	S143	100LB/112MS	4	35000	18500
9,4	2872	1,0	151,43	S123	100LB/112MS	4	30000	11200
9,4	2890	1,6	98,81	S143	112MB/132S/132SA	6	35000	18500
9,0	2987	1,3	157,49	S143	100LB/112MS	4	35000	18500
8,8	3098	1,0	105,91	S123	112MB/132S/132SA	6	30000	11200
8,6	3164	3,0	111,67	S153	132S/132SA	6	40000	19400
8,5	3219	1,5	110,05	S143	112MB/132S/132SA	6	35000	18500
8,3	3291	1,0	112,52	S123	112MB/132S/132SA	6	30000	11200
8,3	3253	1,4	171,55	S143	100LB/112MS	4	35000	18500
8,2	3297	0,9	177,53	S123	112MS	4	30000	11200
8,1	3327	1,3	175,41	S143	100LB/112MS	4	35000	18500
7,8	3494	0,9	123,33	S123	132S/132SA	6	30000	11200
7,8	3473	2,9	122,57	S153	132S/132SA	6	40000	19400
7,5	3610	1,4	123,44	S143	112MB/132S/132SA	6	35000	18500
7,2	3731	1,3	196,74	S143	100LB/112MS	4	35000	18500
6,9	3944	2,4	139,21	S153	132S/132SA	6	40000	19400
6,7	4084	1,2	139,64	S143	112MB/132S/132SA	6	35000	18500
6,4	4221	1,1	222,57	S143	100LB/112MS	4	35000	18500
6,2	4361	1,2	149,10	S143	112MB/132S/132SA	6	35000	18500
6,2	4364	1,7	154,02	S153	132S/132SA	6	40000	19400
6,0	4507	1,1	237,63	S143	100LB/112MS	4	35000	18500
6,0	4534	1,9	160,02	S153	132S/132SA	6	40000	19400
5,4	5017	1,0	171,55	S143	112MB/132S/132SA	6	35000	18500
5,4	5010	1,7	176,81	S153	132S/132SA	6	40000	19400
5,2	5185	0,9	273,41	S143	100LB/112MS	4	35000	18500
4,9	5499	1,7	194,06	S153	132S/132SA	6	40000	19400
4,4	6245	1,6	220,42	S153	132S/132SA	6	40000	19400
3,8	7179	1,2	253,36	S153	132S/132SA	6	40000	19400

4,00 kW

n2 [rpm]	M2 [Nm]	fs	i	Gear reducer	Motor Size	Pole	Fr2 D [N]	Fr2 C-L [N]
358,8	99	2,5	8,00	S062	100LB/112M/112MA	2	5149	2059
332,8	106	1,2	8,63	S052	100LB/112M/112MA	2	2825	2825

4,00 kW

n2 [rpm]	M2 [Nm]	fs	i	Gear reducer	Motor Size	Pole	Fr2 D [N]	Fr2 C-L [N]
321,7	110	2,2	8,92	S062	100LB/112M/112MA	2	5288	2115
300,7	118	2,3	9,55	S062	100LB/112M/112MA	2	5374	2150
288,6	123	4,0	9,94	S082	100LB ⁽¹⁾	2	11667	3333
269,6	131	2,1	10,65	S062	100LB/112M/112MA	2	5513	2205
257,6	137	1,0	11,14	S052	100LB/112M/112MA	2	2948	2948
247,3	143	3,7	11,61	S082	100LB/112M/112MA	2	12231	3495
245,1	144	2,0	11,71	S062	100LB/112M/112MA	2	5632	2253
239,2	148	1,0	12,00	S052	100LB/112M/112MA	2	2980	2980
225,1	157	3,6	12,75	S082	100LB/112M/112MA	2	12585	3596
219,8	161	2,0	13,06	S062	100LB/112M/112MA	2	5767	2307
214,9	165	1,9	13,36	S062	100LB/112M/112MA	2	5794	2318
204,4	173	3,3	14,04	S082	100LB/112M/112MA	2	12958	3702
196,2	187	2,9	7,34	S082	112M/112MA	4	13095	3741
186,0	190	3,0	15,43	S082	100LB/112M/112MA	2	13328	3808
182,5	194	3,0	15,73	S082	100LB/112M/112MA	2	13404	3830
180,1	197	1,7	15,94	S062	100LB/112M/112MA	2	6003	2401
180,0	204	1,6	8,00	S062	112M/112MA	4	5958	2383
178,6	205	2,9	8,06	S082	112M/112MA	4	13467	3848
177,6	199	1,7	16,16	S062	100LB/112M/112MA	2	6019	2408
165,9	213	2,7	17,29	S082	100LB/112M/112MA	2	13788	3939
162,8	225	4,0	8,85	S102	112MA ⁽¹⁾	4	17159	4903
161,4	227	1,5	8,92	S062	112M/112MA	4	6075	2430
150,9	243	1,5	9,55	S062	112M/112MA	4	6144	2458
150,8	235	2,5	19,03	S082	100LB/112M/112MA	2	14182	4052
148,8	238	1,4	19,29	S062	100LB/112M/112MA	2	6212	2485
146,8	241	1,4	19,55	S062	100LB/112M/112MA	2	6226	2490
144,8	253	2,6	9,94	S082	112M/112MA	4	14323	4092
142,5	248	2,3	20,14	S082	100LB/112M/112MA	2	14419	4120
135,3	271	1,3	10,65	S062	112M/112MA	4	6248	2499
132,3	277	3,4	10,88	S102	112M/112MA	4	18281	5223
130,8	283	2,0	7,34	S082	132MA	6	14742	4212
129,7	273	2,2	22,13	S082	100LB/112M/112MA	2	14819	4234
129,7	273	3,8	22,13	S102	100LB/112M/112MA	2	18416	5262
124,1	296	2,4	11,61	S082	112M/112MA	4	14977	4279
123,8	286	1,2	23,18	S062	100LB/112M/112MA	2	6391	2556
123,0	298	1,3	11,71	S062	112M/112MA	4	6330	2532
120,8	293	1,2	23,75	S062	100LB/112M/112MA	2	6412	2565
119,6	296	2,0	24,00	S082	100LB/112M/112MA	2	15171	4334
119,1	311	2,0	8,06	S082	132MA	6	15144	4327
119,1	311	2,9	8,06	S102	132MA	6	18865	5390
118,2	299	3,8	24,28	S102	100LB/112M/112MA	2	18942	5412
114,1	310	1,2	25,14	S062	100LB/112M/112MA	2	6460	2584

⁽¹⁾ Available only with brake motor (TBS)

4,00 kW

n2 [rpm]	M2 [Nm]	fs	i	Gear reducer	Motor Size	Pole	Fr2 D [N]	Fr2 C-L [N]
112,9	325	2,3	12,75	S082	112M/112MA	4	15384	4395
112,9	325	3,1	12,75	S102	112M/112MA	4	19176	5479
110,3	333	1,3	13,06	S062	112M/112MA	4	6414	2566
110,2	321	1,9	26,05	S082	100LB/112M/112MA	2	15530	4437
109,0	325	3,5	26,33	S102	100LB/112M/112MA	2	19413	5546
108,5	341	2,8	8,85	S102	132MA	6	19398	5542
107,8	340	1,2	13,36	S062	112M/112MA	4	6430	2572
105,2	336	2,0	27,29	S082	100LB/112M/112MA	2	15736	4496
103,8	341	1,1	27,66	S062	100LB/112M/112MA	2	6533	2613
102,9	356	3,4	13,99	S102	112M/112MA	4	19716	5633
102,5	358	2,1	14,04	S082	112M/112MA	4	15808	4517
100,1	354	1,9	28,67	S082	100LB/112M/112MA	2	15958	4559
97,0	365	1,8	29,60	S082	100LB/112M/112MA	2	16101	4600
96,5	384	1,8	9,94	S082	132MA	6	16064	4590
96,1	368	3,1	29,87	S102	100LB/112M/112MA	2	20159	5760
95,7	370	1,0	30,00	S062	100LB/112M/112MA	2	6586	2634
93,3	393	2,0	15,43	S082	112M/112MA	4	16228	4637
93,3	393	3,2	15,43	S102	112M/112MA	4	20299	5800
91,6	400	1,9	15,73	S082	112M/112MA	4	16313	4661
90,4	406	1,1	15,94	S062	112M/112MA	4	6528	2611
90,3	392	1,9	31,78	S082	100LB/112M/112MA	2	16422	4692
89,1	412	1,1	16,16	S062	112M/112MA	4	6534	2614
88,6	400	2,8	32,40	S102	100LB/112M/112MA	2	20653	5901
88,2	420	2,4	10,88	S102	132MA	6	20631	5894
83,7	438	3,0	17,21	S102	112M/112MA	4	20965	5990
83,3	440	1,7	17,29	S082	112M/112MA	4	16744	4784
82,7	448	1,6	11,61	S082	132MA	6	16760	4789
82,2	430	1,7	34,91	S082	100LB/112M/112MA	2	16854	4815
82,2	430	2,4	34,91	S102	100LB/112M/112MA	2	21113	6032
80,8	438	1,7	35,50	S082	100LB/112M/112MA	2	16931	4837
79,3	446	1,0	36,57	S062	112M/112MA	2	6673	2669
75,8	484	2,9	19,00	S102	112M/112MA	4	21579	6166
75,7	485	1,6	19,03	S082	112M/112MA	4	17182	4909
75,3	492	1,6	12,75	S082	132MA	6	17189	4911
75,3	492	2,1	12,75	S102	132MA	6	21608	6174
74,9	472	2,4	38,30	S102	100LB/112M/112MA	2	21696	6199
74,7	491	0,9	19,29	S062	112M/112MA	4	6579	2632
73,7	498	0,9	19,55	S062	112M/112MA	4	6580	2632
71,7	494	1,5	40,05	S082	100LB/112M/112MA	2	17493	4998
71,5	513	1,5	20,14	S082	112M/112MA	4	17444	4984
69,1	530	2,6	20,83	S102	112M/112MA	4	22000	6332
68,6	540	2,3	13,99	S102	132MA	6	22000	6342

4,00 kW

n2 [rpm]	M2 [Nm]	fs	i	Gear reducer	Motor Size	Pole	Fr2 D [N]	Fr2 C-L [N]
68,4	542	1,5	14,04	S082	132MA	6	17635	5039
67,5	524	2,0	42,53	S102	100LB/112M/112MA	2	22000	6390
67,3	551	3,4	14,27	S142	132MA	6	35000	18500
66,7	531	1,4	43,05	S082	100LB/112M/112MA	2	17833	5095
65,2	543	1,8	44,00	S102	100LB/112M/112MA	2	22000	6453
65,1	563	1,4	22,13	S082	112M/112MA	4	17881	5109
65,1	563	2,5	22,13	S102	112M/112MA	4	22000	6443
64,3	550	3,3	44,63	S122	100LB/112M/112MA	2	30000	9258
62,2	595	1,4	15,43	S082	132MA	6	18000	5163
62,2	595	2,2	15,43	S102	132MA	6	22000	6522
61,0	607	1,3	15,73	S082	132MA	6	18000	5189
60,9	581	2,1	47,13	S102	100LB/112M/112MA	2	22000	6582
60,0	611	1,3	24,00	S082	112M/112MA	4	18000	5217
60,0	618	3,3	16,01	S142	132MA	6	35000	18500
59,3	618	2,4	24,28	S102	112M/112MA	4	22000	6615
58,5	605	3,0	49,04	S122	100LB/112M/112MA	2	30000	9511
57,1	620	1,2	50,25	S082	100LB/112M/112MA	2	18000	5304
57,1	620	1,7	50,25	S102	100LB/112M/112MA	2	22000	6703
55,8	664	2,1	17,21	S102	132MA	6	22000	6727
55,5	667	1,2	17,29	S082	132MA	6	18000	5315
55,3	663	1,2	26,05	S082	112M/112MA	4	18000	5327
54,7	671	2,2	26,33	S102	112M/112MA	4	22000	6769
53,4	663	2,9	53,75	S122	100LB/112M/112MA	2	30000	9760
53,0	699	3,3	18,11	S142	132MA	6	35000	18500
52,9	669	1,1	54,27	S082	100LB/112M/112MA	2	18000	5409
52,8	695	1,3	27,29	S082	112M/112MA	4	18000	5389
52,1	680	1,4	55,14	S102	100LB/112M/112MA	2	22000	6881
50,5	734	1,1	19,03	S082	132MA	6	18000	5443
50,5	733	2,0	19,00	S102	132MA	6	22000	6915
50,2	730	1,2	28,67	S082	112M/112MA	4	18000	5456
49,7	746	3,3	19,33	S142	132MA	6	35000	18500
48,6	754	1,2	29,60	S082	112M/112MA	4	18000	5498
48,3	732	1,6	59,40	S102	100LB/112M/112MA	2	22000	7026
48,2	761	2,0	29,87	S102	112M/112MA	4	22000	7011
47,7	777	1,0	20,14	S082	132MA	6	18000	5519
47,3	749	1,0	61,98	S082	112M	2	18000	5562
47,2	777	3,9	30,51	S122	112M/112MA	4	30000	10072
46,1	804	1,8	20,83	S102	132MA	6	22000	7092
45,3	809	1,2	31,78	S082	112M/112MA	4	18000	5593
45,2	820	3,6	21,25	S122	132MA	6	30000	10184
44,4	825	1,8	32,40	S102	112M/112MA	4	22000	7169
44,3	783	2,6	64,84	S123	100LB/112M/112MA	2	30000	10299

4,00 kW

n2 [rpm]	M2 [Nm]	fs	i	Gear reducer	Motor Size	Pole	Fr2 D [N]	Fr2 C-L [N]
44,0	834	3,6	32,76	S122	112M/112MA	4	30000	10269
43,5	814	2,8	66,00	S122	100LB/112M/112MA	2	30000	10331
43,4	854	1,0	22,13	S082	132MA	6	18000	5644
43,4	854	1,7	22,13	S102	132MA	6	22000	7210
43,2	858	3,0	22,24	S142	132MA	6	35000	18500
43,1	852	3,5	33,44	S122	112M/112MA	4	30000	10327
42,9	863	3,4	22,37	S122	132MA	6	30000	10326
42,3	836	1,4	67,84	S102	100LB/112M/112MA	2	22000	7288
41,3	889	1,1	34,91	S082	112M/112MA	4	18000	5719
41,3	889	1,6	34,91	S102	112M/112MA	4	22000	7316
41,2	899	3,4	23,29	S122	132MA	6	30000	10439
40,9	896	3,3	35,20	S122	112M/112MA	4	30000	10470
40,6	904	1,1	35,50	S082	112M/112MA	4	18000	5741
40,4	858	2,4	71,07	S123	100LB/112M/112MA	2	30000	10561
40,0	926	0,9	24,00	S082	132MA	6	18000	5751
39,5	937	1,7	24,28	S102	132MA	6	22000	7392
38,7	896	1,3	74,18	S103	100LB/112M/112MA	2	22000	7481
38,0	975	2,3	25,26	S142	132MA	6	35000	18500
37,6	975	1,5	38,30	S102	112M/112MA	4	22000	7499
36,7	1009	3,1	26,15	S122	132MA	6	30000	10765
36,6	947	2,4	78,46	S123	100LB/112M/112MA	2	30000	10845
36,5	1016	1,6	26,33	S102	132MA	6	22000	7553
36,0	1020	1,0	40,05	S082	112M/112MA	4	18000	5900
35,5	1042	0,9	27,29	S082	132MA	6	18000	5905
35,3	983	1,2	81,39	S103	100LB/112M/112MA	2	22000	7670
35,1	1046	2,9	41,07	S122	112M/112MA	4	30000	10905
33,9	1083	1,3	42,53	S102	112M/112MA	4	22000	7708
33,9	1093	2,3	28,33	S142	132MA	6	35000	18500
33,6	1103	2,9	28,60	S122	132MA	6	30000	11018
33,4	1096	0,9	43,05	S082	112M/112MA	4	18000	5994
33,0	1110	2,7	43,60	S122	112M/112MA	4	30000	11075
32,9	1054	2,1	87,27	S123	100LB/112M/112MA	2	30000	11154
32,7	1121	1,2	44,00	S102	112M/112MA	4	22000	7777
32,3	1137	2,1	44,63	S122	112M/112MA	4	30000	11142
32,1	1152	1,4	29,87	S102	132MA	6	22000	7805
32,0	1084	1,1	89,77	S103	100LB/112M/112MA	2	22000	7871
31,5	1177	2,7	30,51	S122	132MA	6	30000	11200
31,5	1141	3,5	45,77	S143	112M/112MA	4	35000	18500
30,6	1200	1,3	47,13	S102	112M/112MA	4	22000	7915
30,0	1237	2,3	32,05	S142	132MA	6	35000	18500
29,6	1250	1,3	32,40	S102	132MA	6	22000	7968
29,4	1249	1,9	49,04	S122	112M/112MA	4	30000	11200

4,00 kW

n2 [rpm]	M2 [Nm]	fs	i	Gear reducer	Motor Size	Pole	Fr2 D [N]	Fr2 C-L [N]
29,3	1264	2,5	32,76	S122	132MA	6	30000	11200
29,0	1197	1,0	100,15	S103	112M/112MA	2	22000	8075
28,7	1280	1,1	50,25	S102	112M/112MA	4	22000	8044
28,7	1290	2,4	33,44	S122	132MA	6	30000	11200
28,3	1271	3,5	50,97	S143	112M/112MA	4	35000	18500
28,1	1320	2,3	34,22	S142	132MA	6	35000	18500
27,5	1347	1,1	34,91	S102	132MA	6	22000	8118
27,3	1358	2,3	35,20	S122	132MA	6	30000	11200
27,1	1279	1,8	105,91	S123	100LB/112M/112MA	2	30000	11200
26,8	1369	1,9	53,75	S122	112M/112MA	4	30000	11200
26,1	1404	0,9	55,14	S102	112M/112MA	4	22000	8232
25,5	1358	1,7	112,52	S123	100LB/112M/112MA	2	30000	11200
25,2	1426	3,3	57,17	S143	112M/112MA	4	35000	18500
25,1	1478	1,1	38,30	S102	132MA	6	22000	8304
24,4	1519	3,1	39,38	S142	132MA	6	35000	18500
24,2	1513	1,1	59,40	S102	112M/112MA	4	22000	8382
23,4	1584	2,0	41,07	S122	132MA	6	30000	11200
23,3	1489	1,5	123,33	S123	100LB/112M/112MA	2	30000	11200
22,8	1624	0,9	42,53	S102	132MA	6	22000	8493
22,3	1613	3,0	64,68	S143	112M/112MA	4	35000	18500
22,2	1617	1,7	64,84	S123	112M/112MA	4	30000	11200
22,1	1570	1,4	130,04	S123	100LB/112M/112MA	2	30000	11200
22,0	1682	1,9	43,60	S122	132MA	6	30000	11200
21,8	1681	1,8	66,00	S122	112M/112MA	4	30000	11200
21,5	1722	1,5	44,63	S122	132MA	6	30000	11200
21,5	1615	1,4	133,78	S123	100LB/112M/112MA	2	30000	11200
21,2	1728	0,9	67,84	S102	112M/112MA	4	22000	8649
21,0	1729	2,4	45,77	S143	132MA	6	35000	18500
20,9	1722	2,8	69,06	S143	112M/112MA	4	35000	18500
20,4	1818	0,9	47,13	S102	132MA	6	22000	8717
20,3	1772	1,5	71,07	S123	112M/112MA	4	30000	11200
19,6	1892	1,3	49,04	S122	132MA	6	30000	11200
19,0	1828	1,2	151,43	S123	100LB/112M/112MA	2	30000	11200
18,8	1926	2,4	50,97	S143	132MA	6	35000	18500
18,4	1957	1,5	78,46	S123	112M/112MA	4	30000	11200
18,1	1981	2,1	79,45	S143	112M/112MA	4	35000	18500
17,9	2074	1,3	53,75	S122	132MA	6	30000	11200
16,8	2160	2,3	57,17	S143	132MA	6	35000	18500
16,5	2176	1,4	87,27	S123	112M/112MA	4	30000	11200
16,2	2143	1,0	177,53	S123	100LB/112M/112MA	2	30000	11200
15,0	2420	3,8	64,05	S153	132MA	6	40000	19400
14,8	2450	1,2	64,84	S123	132MA	6	30000	11200

4,00 kW

n2 [rpm]	M2 [Nm]	fs	i	Gear reducer	Motor Size	Pole	Fr2 D [N]	Fr2 C-L [N]
14,8	2443	2,1	64,68	S143	132MA	6	35000	18500
14,6	2464	1,8	98,81	S143	112M/112MA	4	35000	18500
14,5	2546	1,2	66,00	S122	132MA	6	30000	11200
13,9	2609	2,0	69,06	S143	132MA	6	35000	18500
13,6	2641	1,1	105,91	S123	112M/112MA	4	30000	11200
13,5	2685	1,1	71,07	S123	132MA	6	30000	11200
13,1	2744	1,7	110,05	S143	112M/112MA	4	35000	18500
13,0	2781	2,9	73,63	S153	132MA	6	40000	19400
12,8	2806	1,1	112,52	S123	112M/112MA	4	30000	11200
12,2	2964	1,1	78,46	S123	132MA	6	30000	11200
12,1	3002	1,5	79,45	S143	132MA	6	35000	18500
11,7	3075	1,0	123,33	S123	112M/112MA	4	30000	11200
11,7	3078	1,5	123,44	S143	112M/112MA	4	35000	18500
11,1	3243	0,9	130,04	S123	112M/112MA	4	30000	11200
11,0	3297	1,0	87,27	S123	132MA	6	30000	11200
11,0	3293	2,3	87,16	S153	132MA	6	40000	19400
10,8	3313	0,9	133,78	S123	112M	4	30000	11200
10,3	3482	1,4	139,64	S143	112M/112MA	4	35000	18500
9,9	3675	2,3	97,27	S153	132MA	6	40000	19400
9,7	3733	1,2	98,81	S143	132MA	6	35000	18500
9,7	3718	1,3	149,10	S143	112M/112MA	4	35000	18500
9,1	3927	1,0	157,49	S143	112M/112MA	4	35000	18500
8,7	4158	1,2	110,05	S143	132MA	6	35000	18500
8,6	4219	2,3	111,67	S153	132MA	6	40000	19400
8,4	4278	1,1	171,55	S143	112M/112MA	4	35000	18500
8,2	4374	1,0	175,41	S143	112M/112MA	4	35000	18500
7,8	4663	1,1	123,44	S143	132MA	6	35000	18500
7,8	4630	2,2	122,57	S153	132MA	6	40000	19400
7,3	4906	1,0	196,74	S143	112M/112MA	4	35000	18500
6,9	5276	1,0	139,64	S143	132MA	6	35000	18500
6,9	5259	1,8	139,21	S153	132MA	6	40000	19400
6,5	5575	0,9	149,10	S143	132MA	6	35000	18500
6,2	5819	1,3	154,02	S153	132MA	6	40000	19400
6,0	6045	1,4	160,02	S153	132MA	6	40000	19400
5,4	6680	1,3	176,81	S153	132MA	6	40000	19400
4,9	7331	1,3	194,06	S153	132MA	6	40000	19400
4,4	8327	1,2	220,42	S153	132MA	6	40000	19400
3,8	9571	0,9	253,36	S153	132MA	6	40000	19400

4,80 kW

n2 [rpm]	M2 [Nm]	fs	i	Gear reducer	Size	Motor Pole	Fr2 D [N]	Fr2 C-L [N]
194,9	226	2,4	7,34	S082	112MB ⁽¹⁾	4	12999	3714
178,8	246	1,3	8,00	S062	112MB ⁽¹⁾	4	5706	2282
177,4	248	2,4	8,06	S082	112MB ⁽¹⁾	4	13359	3817
177,4	248	3,4	8,06	S102	112MB ⁽¹⁾	4	16604	4744
161,6	272	3,3	8,85	S102	112MB ⁽¹⁾	4	17078	4879
160,3	275	1,2	8,92	S062	112MB ⁽¹⁾	4	5792	2317
149,8	294	1,2	9,55	S062	112MB ⁽¹⁾	4	5840	2336
143,8	306	2,1	9,94	S082	112MB ⁽¹⁾	4	14184	4053
134,3	328	1,1	10,65	S062	112MB ⁽¹⁾	4	5908	2363
131,4	335	2,8	10,88	S102	112MB ⁽¹⁾	4	18175	5193
123,2	357	2,0	11,61	S082	112MB ⁽¹⁾	4	14811	4232
122,1	360	1,1	11,71	S062	112MB ⁽¹⁾	4	5955	2382
112,2	392	1,9	12,75	S082	112MB ⁽¹⁾	4	15199	4343
112,2	392	2,5	12,75	S102	112MB ⁽¹⁾	4	19046	5442
109,5	402	1,0	13,06	S062	112MB ⁽¹⁾	4	5994	2398
107,1	411	1,0	13,36	S062	112MB ⁽¹⁾	4	6000	2400
102,2	431	2,8	13,99	S102	112MB ⁽¹⁾	4	19571	5592
101,8	432	1,8	14,04	S082	112MB ⁽¹⁾	4	15603	4458
92,7	475	1,6	15,43	S082	112MB ⁽¹⁾	4	15999	4571
92,7	475	2,6	15,43	S102	112MB ⁽¹⁾	4	20136	5753
90,9	484	1,6	15,73	S082	112MB ⁽¹⁾	4	16080	4594
89,7	490	0,9	15,94	S062	112MB ⁽¹⁾	4	6013	2405
88,5	497	0,9	16,16	S062	112MB ⁽¹⁾	4	6012	2405
83,1	530	2,5	17,21	S102	112MB ⁽¹⁾	4	20779	5937
82,7	532	1,4	17,29	S082	112MB ⁽¹⁾	4	16485	4710
75,3	585	2,4	19,00	S102	112MB ⁽¹⁾	4	21370	6106
75,2	586	1,3	19,03	S082	112MB ⁽¹⁾	4	16894	4827
71,0	620	1,2	20,14	S082	112MB ⁽¹⁾	4	17137	4896
68,7	641	2,2	20,83	S102	112MB ⁽¹⁾	4	21929	6265
64,6	681	1,2	22,13	S082	112MB ⁽¹⁾	4	17540	5012
64,6	681	2,1	22,13	S102	112MB ⁽¹⁾	4	22000	6371
59,6	739	1,1	24,00	S082	112MB ⁽¹⁾	4	17889	5111
58,9	747	2,0	24,28	S102	112MB ⁽¹⁾	4	22000	6536
54,9	802	1,0	26,05	S082	112MB ⁽¹⁾	4	18000	5211
54,7	805	3,7	26,15	S122	112MB ⁽¹⁾	4	30000	9525
54,3	810	1,9	26,33	S102	112MB ⁽¹⁾	4	22000	6682
52,4	840	1,1	27,29	S082	112MB ⁽¹⁾	4	18000	5267
50,0	880	3,4	28,60	S122	112MB ⁽¹⁾	4	30000	9755
49,9	882	1,0	28,67	S082	112MB ⁽¹⁾	4	18000	5327
48,3	911	1,0	29,60	S082	112MB ⁽¹⁾	4	18000	5365
47,9	919	1,6	29,87	S102	112MB ⁽¹⁾	4	22000	6911
46,9	939	3,2	30,51	S122	112MB ⁽¹⁾	4	30000	9922

⁽¹⁾ Available only with brake motor (TBS)

4,80 kW

n2 [rpm]	M2 [Nm]	fs	i	Gear reducer	Motor Size	Pole	Fr2 D [N]	Fr2 C-L [N]
45,0	978	1,0	31,78	S082	112MB ⁽¹⁾	4	18000	5450
44,1	997	1,5	32,40	S102	112MB ⁽¹⁾	4	22000	7059
43,7	1008	3,0	32,76	S122	112MB ⁽¹⁾	4	30000	10106
42,8	1029	2,9	33,44	S122	112MB ⁽¹⁾	4	30000	10161
41,0	1074	0,9	34,91	S082	112MB ⁽¹⁾	4	18000	5560
41,0	1074	1,3	34,91	S102	112MB ⁽¹⁾	4	22000	7197
40,6	1083	2,8	35,20	S122	112MB ⁽¹⁾	4	30000	10294
40,3	1092	0,9	35,50	S082	112MB ⁽¹⁾	4	18000	5579
37,3	1179	1,3	38,30	S102	112MB ⁽¹⁾	4	22000	7368
34,8	1264	2,4	41,07	S122	112MB ⁽¹⁾	4	30000	10697
33,6	1309	1,1	42,53	S102	112MB ⁽¹⁾	4	22000	7561
32,8	1342	2,2	43,60	S122	112MB ⁽¹⁾	4	30000	10853
32,5	1354	1,0	44,00	S102	112MB ⁽¹⁾	4	22000	7623
32,0	1373	1,7	44,63	S122	112MB ⁽¹⁾	4	30000	10914
31,2	1379	2,9	45,77	S143	112MB ⁽¹⁾	4	35000	18500
30,3	1450	1,1	47,13	S102	112MB ⁽¹⁾	4	22000	7750
29,2	1509	1,6	49,04	S122	112MB ⁽¹⁾	4	30000	11159
28,5	1546	0,9	50,25	S102	112MB ⁽¹⁾	4	22000	7867
28,1	1536	2,9	50,97	S143	112MB ⁽¹⁾	4	35000	18500
26,6	1654	1,6	53,75	S122	112MB ⁽¹⁾	4	30000	11200
25,0	1723	2,7	57,17	S143	112MB ⁽¹⁾	4	35000	18500
22,1	1954	1,4	64,84	S123	112MB ⁽¹⁾	4	30000	11200
22,1	1949	2,4	64,68	S143	112MB ⁽¹⁾	4	35000	18500
21,7	2031	1,5	66,00	S122	112MB ⁽¹⁾	4	30000	11200
20,7	2081	2,3	69,06	S143	112MB ⁽¹⁾	4	35000	18500
20,1	2142	1,3	71,07	S123	112MB ⁽¹⁾	4	30000	11200
18,2	2364	1,3	78,46	S123	112MB ⁽¹⁾	4	30000	11200
18,0	2394	1,8	79,45	S143	112MB ⁽¹⁾	4	35000	18500
16,4	2630	1,1	87,27	S123	112MB ⁽¹⁾	4	30000	11200
14,5	2977	1,5	98,81	S143	112MB ⁽¹⁾	4	35000	18500
13,5	3191	0,9	105,91	S123	112MB ⁽¹⁾	4	30000	11200
13,0	3316	1,4	110,05	S143	112MB ⁽¹⁾	4	35000	18500
11,6	3720	1,3	123,44	S143	112MB ⁽¹⁾	4	35000	18500
10,2	4208	1,2	139,64	S143	112MB ⁽¹⁾	4	35000	18500
9,6	4493	1,1	149,10	S143	112MB ⁽¹⁾	4	35000	18500
8,3	5169	0,9	171,55	S143	112MB ⁽¹⁾	4	35000	18500

5,50 kW

n2 [rpm]	M2 [Nm]	fs	i	Gear reducer	Motor Size	Pole	Fr2 D [N]	Fr2 C-L [N]
396,5	123	3,4	7,34	S082	112MB/132SA/132S	2	10466	2990
363,8	134	1,9	8,00	S062	112MB ⁽¹⁾	2	4900	1960

⁽¹⁾ Available only with brake motor (TBS)

5,50 kW

n2 [rpm]	M2 [Nm]	fs	i	Gear reducer	Motor Size	Pole	Fr2 D [N]	Fr2 C-L [N]
360,9	135	3,3	8,06	S082	112MB/132SA/132S	2	10769	3077
326,2	149	1,7	8,92	S062	112MB ⁽¹⁾	2	5013	2005
304,9	160	1,7	9,55	S062	112MB ⁽¹⁾	2	5081	2032
292,6	166	2,9	9,94	S082	112MB/132SA/132S	2	11469	3277
273,4	178	1,5	10,65	S062	112MB ⁽¹⁾	2	5187	2075
267,4	182	3,9	10,88	S102	112MB/132SA/132S	2	14591	4169
250,7	194	2,7	11,61	S082	112MB/132SA/132S	2	12006	3430
248,5	196	1,5	11,71	S062	112MB ⁽¹⁾	2	5276	2111
228,2	213	2,6	12,75	S082	112MB/132SA/132S	2	12342	3526
228,2	213	3,5	12,75	S102	112MB/132SA/132S	2	15318	4377
222,9	218	1,4	13,06	S062	112MB ⁽¹⁾	2	5372	2149
217,9	223	1,4	13,36	S062	112MB ⁽¹⁾	2	5391	2156
208,0	234	3,8	13,99	S102	112MB/132SA/132S	2	15758	4502
207,2	235	2,4	14,04	S082	112MB/132SA/132S	2	12693	3627
197,6	255	2,2	7,34	S082	132MS/132S	4	12840	3668
188,6	258	2,2	15,43	S082	112MB/132SA/132S	2	13042	3726
188,6	258	3,6	15,43	S102	112MB/132SA/132S	2	16232	4638
185,1	263	2,2	15,73	S082	112MB/132SA/132S	2	13113	3747
182,6	266	1,3	15,94	S062	112MB ⁽¹⁾	2	5526	2210
180,0	270	1,2	16,16	S062	112MB ⁽¹⁾	2	5536	2214
179,8	280	2,1	8,06	S082	132MS/132S	4	13188	3768
179,8	280	3,0	8,06	S102	132MS/132S	4	16442	4698
169,1	288	3,4	17,21	S102	112MB/132SA/132S	2	16776	4793
168,3	289	2,0	17,29	S082	112MB/132SA/132S	2	13472	3849
163,9	308	2,9	8,85	S102	132MS/132S	4	16905	4830
153,2	318	3,3	19,00	S102	112MB/132SA/132S	2	17280	4937
152,9	318	1,8	19,03	S082	112MB/132SA/132S	2	13839	3954
150,9	322	1,0	19,29	S062	112MB ⁽¹⁾	2	5640	2256
148,8	327	1,1	19,55	S062	112MB ⁽¹⁾	2	5647	2259
145,8	346	1,9	9,94	S082	132MS/132S	4	13984	3995
144,5	337	1,7	20,14	S082	112MB/132SA/132S	2	14059	4017
139,7	348	3,0	20,83	S102	112MB/132SA/132S	2	17758	5074
133,2	379	2,5	10,88	S102	132MS/132S	4	17975	5136
131,5	370	1,6	22,13	S082	112MB/132SA/132S	2	14428	4122
131,5	370	2,8	22,13	S102	112MB/132SA/132S	2	18077	5165
131,2	388	3,8	7,32	S142	132MB	6	35000	18500
130,8	389	1,5	7,34	S082	132MB	6	14393	4112
124,9	404	1,7	11,61	S082	132MS/132S	4	14585	4167
121,3	401	1,5	24,00	S082	112MB/132SA/132S	2	14751	4215
119,9	406	2,8	24,28	S102	112MB/132SA/132S	2	18576	5307
119,1	428	1,5	8,06	S082	132MB	6	14761	4217
119,1	428	2,1	8,06	S102	132MB	6	18562	5304

⁽¹⁾ Available only with brake motor (TBS)

5,50 kW

n2 [rpm]	M2 [Nm]	fs	i	Gear reducer	Motor Size	Pole	Fr2 D [N]	Fr2 C-L [N]
117,0	435	3,8	8,21	S142	132MB	6	35000	18500
113,7	443	1,7	12,75	S082	132MS/132S	4	14956	4273
113,7	443	2,3	12,75	S102	132MS/132S	4	18822	5378
111,7	436	1,4	26,05	S082	112MB/132SA/132S	2	15079	4308
110,5	440	2,6	26,33	S102	112MB/132SA/132S	2	19020	5434
108,5	469	2,0	8,85	S102	132MB	6	19066	5447
106,6	456	1,5	27,29	S082	112MB/132SA/132S	2	15266	4362
103,6	486	2,5	13,99	S102	132MS/132S	4	19331	5523
103,4	493	3,8	9,29	S142	132MB	6	35000	18500
103,2	488	1,6	14,04	S082	132MS/132S	4	15340	4383
101,6	496	3,6	14,27	S142	132MS/132S	4	35000	18500
101,5	479	1,4	28,67	S082	112MB/132SA/132S	2	15466	4419
98,3	495	1,4	29,60	S082	112MB/132SA/132S	2	15595	4456
97,4	499	2,3	29,87	S102	112MB/132SA/132S	2	19723	5635
96,8	526	3,8	9,91	S142	132MB	6	35000	18500
96,5	528	1,3	9,94	S082	132MB	6	15591	4455
94,0	537	1,4	15,43	S082	132MS/132S	4	15716	4490
94,0	537	2,3	15,43	S102	132MS/132S	4	19878	5679
92,2	547	1,4	15,73	S082	132MS/132S	4	15792	4512
91,6	531	1,4	31,78	S082	112MB/132SA/132S	2	15883	4538
90,6	557	3,5	16,01	S142	132MS/132S	4	35000	18500
89,8	542	2,1	32,40	S102	112MB/132SA/132S	2	20185	5767
88,2	577	1,7	10,88	S102	132MB	6	20222	5778
84,2	599	2,2	17,21	S102	132MS/132S	4	20499	5857
84,2	605	3,6	11,41	S142	132MB	6	35000	18500
83,8	601	1,3	17,29	S082	132MS/132S	4	16174	4621
83,4	584	1,3	34,91	S082	112MB/132SA/132S	2	16267	4648
83,4	584	1,8	34,91	S102	112MB/132SA/132S	2	20614	5890
82,7	616	1,2	11,61	S082	132MB	6	16208	4631
82,7	589	3,8	35,20	S122	112MB/132SA/132S	2	29516	8433
82,0	594	1,3	35,50	S082	112MB ⁽¹⁾	2	16335	4667
80,1	630	3,5	18,11	S142	132MS/132S	4	35000	18500
76,3	661	2,1	19,00	S102	132MS/132S	4	21068	6020
76,2	662	1,2	19,03	S082	132MS/132S	4	16557	4731
76,0	640	1,8	38,30	S102	112MB/132SA/132S	2	21155	6044
75,3	676	1,2	12,75	S082	132MB	6	16583	4738
75,3	676	1,6	12,75	S102	132MB	6	21129	6037
75,0	672	3,5	19,33	S142	132MS/132S	4	35000	18500
74,9	680	3,0	12,81	S142	132MB	6	35000	18500
72,7	670	1,1	40,05	S082	112MB ⁽¹⁾	2	16828	4808
72,0	700	1,1	20,14	S082	132MS/132S	4	16784	4796
70,9	687	3,3	41,07	S122	112MB/132SA/132S	2	30000	8800

⁽¹⁾ Available only with brake motor (TBS)

5,50 kW

n2 [rpm]	M2 [Nm]	fs	i	Gear reducer	Motor Size	Pole	Fr2 D [N]	Fr2 C-L [N]
69,6	724	1,9	20,83	S102	132MS/132S	4	21605	6173
68,6	742	1,7	13,99	S102	132MB	6	21670	6191
68,4	745	1,1	14,04	S082	132MB	6	16967	4848
68,4	711	1,5	42,53	S102	112MB/132SA/132S	2	21773	6221
68,2	739	3,8	21,25	S122	132MS/132S	4	30000	8863
67,6	720	1,0	43,05	S082	112MB/132SA/132S	2	17122	4892
67,3	757	2,5	14,27	S142	132MB	6	35000	18500
66,7	729	3,1	43,60	S122	112MB/132SA/132S	2	30000	8945
66,1	736	1,3	44,00	S102	112MB ⁽¹⁾	2	21976	6279
65,5	769	1,0	22,13	S082	132MS/132S	4	17159	4903
65,5	769	1,8	22,13	S102	132MS/132S	4	21960	6274
65,2	746	2,4	44,63	S122	112MB/132SA/132S	2	30000	9001
65,2	774	3,1	22,24	S142	132MS/132S	4	35000	18500
64,8	778	3,6	22,37	S122	132MS/132S	4	30000	8986
62,3	810	3,6	23,29	S122	132MS/132S	4	30000	9083
62,2	818	1,0	15,43	S082	132MB	6	17338	4954
62,2	818	1,6	15,43	S102	132MB	6	22000	6356
61,7	788	1,5	47,13	S102	112MB/132SA/132S	2	22000	6396
61,0	834	1,0	15,73	S082	132MB	6	17412	4975
60,4	835	1,0	24,00	S082	132MS/132S	4	17481	4994
60,0	849	2,4	16,01	S142	132MB	6	35000	18500
59,7	844	1,8	24,28	S102	132MS/132S	4	22000	6432
59,3	820	2,2	49,04	S122	112MB/132SA/132S	2	30000	9231
57,9	840	1,2	50,25	S102	112MB ⁽¹⁾	2	22000	6507
57,4	878	2,4	25,26	S142	132MS/132S	4	35000	18500
55,8	913	1,5	17,21	S102	132MB	6	22000	6542
55,4	910	3,3	26,15	S122	132MS/132S	4	30000	9364
55,1	916	1,6	26,33	S102	132MS/132S	4	22000	6571
54,1	899	2,2	53,75	S122	112MB/132SA/132S	2	30000	9457
53,1	949	0,9	27,29	S082	132MS/132S	4	17980	5137
53,0	961	2,4	18,11	S142	132MB	6	35000	18500
52,8	922	1,1	55,14	S102	112MB ⁽¹⁾	2	22000	6668
51,2	985	2,4	28,33	S142	132MS/132S	4	35000	18500
50,7	995	3,0	28,60	S122	132MS/132S	4	30000	9582
50,6	997	0,9	28,67	S082	132MS/132S	4	18000	5191
50,5	1008	1,5	19,00	S102	132MB	6	22000	6711
49,7	1026	2,4	19,33	S142	132MB	6	35000	18500
49,0	993	1,2	59,40	S102	112MB ⁽¹⁾	2	22000	6798
48,5	1039	1,4	29,87	S102	132MS/132S	4	22000	6787
47,5	1061	2,8	30,51	S122	132MS/132S	4	30000	9740
46,1	1105	1,3	20,83	S102	132MB	6	22000	6869
45,6	1105	0,9	31,78	S082	132MS/132S	4	18000	5301

⁽¹⁾ Available only with brake motor (TBS)

5,50 kW

n2 [rpm]	M2 [Nm]	fs	i	Gear reducer	Motor Size	Pole	Fr2 D [N]	Fr2 C-L [N]
45,2	1127	2,6	21,25	S122	132MB	6	30000	9852
45,2	1115	2,4	32,05	S142	132MS/132S	4	35000	18500
44,9	1062	1,9	64,84	S123	112MB/132SA/132S	2	30000	9947
44,8	1127	1,3	32,40	S102	132MS/132S	4	22000	6928
44,3	1139	2,6	32,76	S122	132MS/132S	4	30000	9913
44,1	1104	2,0	66,00	S122	112MB/132SA/132S	2	30000	9966
43,4	1174	1,3	22,13	S102	132MB	6	22000	6972
43,4	1163	2,6	33,44	S122	132MS/132S	4	30000	9964
43,2	1180	2,2	22,24	S142	132MB	6	35000	18500
42,9	1134	1,1	67,84	S102	112MB ⁽¹⁾	2	22000	7031
42,9	1187	2,5	22,37	S122	132MB	6	30000	9976
42,4	1190	2,4	34,22	S142	132MS/132S	4	35000	18500
41,5	1214	1,2	34,91	S102	132MS/132S	4	22000	7056
41,2	1236	2,5	23,29	S122	132MB	6	30000	10075
41,2	1224	2,5	35,20	S122	132MS/132S	4	30000	10089
40,9	1164	1,7	71,07	S123	112MB/132SA/132S	2	30000	10177
39,5	1288	1,2	24,28	S102	132MB	6	22000	7132
38,0	1340	1,7	25,26	S142	132MB	6	35000	18500
37,9	1332	1,1	38,30	S102	132MS/132S	4	22000	7216
37,1	1285	1,8	78,46	S123	112MB/132SA/132S	2	30000	10426
36,8	1369	3,2	39,38	S142	132MS/132S	4	35000	18500
36,7	1387	2,3	26,15	S122	132MB	6	30000	10355
36,5	1397	1,1	26,33	S102	132MB	6	22000	7271
35,3	1428	2,1	41,07	S122	132MS/132S	4	30000	10464
34,1	1479	0,9	42,53	S102	132MS/132S	4	22000	7395
33,9	1503	1,7	28,33	S142	132MB	6	35000	18500
33,6	1517	2,1	28,60	S122	132MB	6	30000	10570
33,3	1516	2,0	43,60	S122	132MS/132S	4	30000	10608
33,3	1429	1,6	87,27	S123	112MB/132SA/132S	2	30000	10692
32,5	1552	1,5	44,63	S122	132MS/132S	4	30000	10664
32,1	1585	1,0	29,87	S102	132MB	6	22000	7484
31,7	1558	2,6	45,77	S143	132MS/132S	4	35000	18500
31,5	1619	1,9	30,51	S122	132MB	6	30000	10724
30,8	1639	1,0	47,13	S102	132MS/132S	4	22000	7570
30,0	1700	1,7	32,05	S142	132MB	6	35000	18500
29,6	1719	0,9	32,40	S102	132MB	6	22000	7620
29,6	1705	1,4	49,04	S122	132MS/132S	4	30000	10888
29,3	1738	1,8	32,76	S122	132MB	6	30000	10890
28,7	1774	1,8	33,44	S122	132MB	6	30000	10939
28,4	1736	2,6	50,97	S143	132MS/132S	4	35000	18500
28,1	1815	1,7	34,22	S142	132MB	6	35000	18500
27,5	1734	1,3	105,91	S123	112MB/132SA/132S	2	30000	11169

⁽¹⁾ Available only with brake motor (TBS)

5,50 kW

n2 [rpm]	M2 [Nm]	fs	i	Gear reducer	Motor Size	Pole	Fr2 D [N]	Fr2 C-L [N]
27,3	1867	1,7	35,20	S122	132MB	6	30000	11057
27,0	1869	1,4	53,75	S122	132MS/132S	4	30000	11102
25,9	1842	1,2	112,52	S123	112MB/132SA/132S	2	30000	11200
25,4	1947	2,4	57,17	S143	132MS/132S	4	35000	18500
24,4	2089	2,2	39,38	S142	132MB	6	35000	18500
23,9	2083	3,2	40,10	S153	132MB	6	40000	19400
23,6	2019	1,1	123,33	S123	112MB/132SA/132S	2	30000	11200
23,4	2179	1,4	41,07	S122	132MB	6	30000	11200
22,4	2208	1,2	64,84	S123	132MS/132S	4	30000	11200
22,4	2129	1,1	130,04	S123	112MB/132SA/132S	2	30000	11200
22,4	2202	2,2	64,68	S143	132MS/132S	4	35000	18500
22,0	2313	1,4	43,60	S122	132MB	6	30000	11200
22,0	2295	1,3	66,00	S122	132MS/132S	4	30000	11200
21,8	2190	1,0	133,78	S123	112MB/132SA/132S	2	30000	11200
21,5	2368	1,1	44,63	S122	132MB	6	30000	11200
21,4	2325	3,2	44,76	S153	132MB	6	40000	19400
21,0	2377	1,8	45,77	S143	132MB	6	35000	18500
21,0	2351	2,1	69,06	S143	132MS/132S	4	35000	18500
20,4	2420	1,1	71,07	S123	132MS/132S	4	30000	11200
19,7	2507	3,1	73,63	S153	132MS/132S	4	40000	19400
19,6	2602	1,0	49,04	S122	132MB	6	30000	11200
18,8	2648	1,8	50,97	S143	132MB	6	35000	18500
18,7	2669	3,1	51,38	S153	132MB	6	40000	19400
18,5	2672	1,1	78,46	S123	132MS/132S	4	30000	11200
18,2	2705	1,6	79,45	S143	132MS/132S	4	35000	18500
17,9	2851	1,0	53,75	S122	132MB	6	30000	11200
17,0	2929	3,0	56,39	S153	132MB	6	40000	19400
16,8	2970	1,7	57,17	S143	132MB	6	35000	18500
16,6	2971	1,0	87,27	S123	132MS/132S	4	30000	11200
16,6	2968	2,4	87,16	S153	132MS/132S	4	40000	19400
15,0	3327	2,8	64,05	S153	132MB	6	40000	19400
14,9	3312	2,4	97,27	S153	132MS/132S	4	40000	19400
14,8	3360	1,5	64,68	S143	132MB	6	35000	18500
14,7	3465	0,9	66,00	S122	132MB	6	30000	11200
14,7	3365	1,3	98,81	S143	132MS/132S	4	35000	18500
13,9	3587	1,4	69,06	S143	132MB	6	35000	18500
13,2	3747	1,3	110,05	S143	132MS/132S	4	35000	18500
13,0	3824	2,1	73,63	S153	132MB	6	40000	19400
13,0	3802	2,4	111,67	S153	132MS/132S	4	40000	19400
12,1	4127	1,1	79,45	S143	132MB	6	35000	18500
11,8	4173	2,3	122,57	S153	132MS/132S	4	40000	19400
11,7	4203	1,1	123,44	S143	132MS/132S	4	35000	18500

5,50 kW

n2 [rpm]	M2 [Nm]	fs	i	Gear reducer	Motor Size	Pole	Fr2 D [N]	Fr2 C-L [N]
11,0	4527	1,6	87,16	S153	132MB	6	40000	19400
10,4	4755	1,0	139,64	S143	132MS/132S	4	35000	18500
10,4	4740	1,9	139,21	S153	132MS/132S	4	40000	19400
9,9	5053	1,6	97,27	S153	132MB	6	40000	19400
9,7	5133	0,9	98,81	S143	132MB	6	35000	18500
9,7	5077	0,9	149,10	S143	132MS/132S	4	35000	18500
9,4	5244	1,4	154,02	S153	132MS/132S	4	40000	19400
9,1	5449	1,5	160,02	S153	132MS/132S	4	40000	19400
8,6	5801	1,6	111,67	S153	132MB	6	40000	19400
8,2	6021	1,4	176,81	S153	132MS/132S	4	40000	19400
7,8	6367	1,6	122,57	S153	132MB	6	40000	19400
7,5	6608	1,4	194,06	S153	132MS/132S	4	40000	19400
6,9	7231	1,3	139,21	S153	132MB	6	40000	19400
6,6	7505	1,2	220,42	S153	132MS/132S	4	40000	19400
6,2	8000	0,9	154,02	S153	132MB	6	40000	19400
6,0	8312	1,0	160,02	S153	132MB	6	40000	19400
5,7	8627	1,0	253,36	S153	132MS/132S	4	40000	19400
5,4	9185	0,9	176,81	S153	132MB	6	40000	19400
4,9	10081	0,9	194,06	S153	132MB	6	40000	19400

7,50 kW

n2 [rpm]	M2 [Nm]	fs	i	Gear reducer	Motor Size	Pole	Fr2 D [N]	Fr2 C-L [N]
396,5	167	2,5	7,34	S082	132M/132SB	2	10319	2948
360,9	184	2,4	8,06	S082	132M/132SB	2	10608	3031
360,9	184	3,5	8,06	S102	132M/132SB	2	13166	3762
328,9	202	3,3	8,85	S102	132M/132SB	2	13544	3870
292,6	227	2,2	9,94	S082	132M/132SB	2	11270	3220
267,4	248	2,9	10,88	S102	132M/132SB	2	14420	4120
250,7	265	2,0	11,61	S082	132M/132SB	2	11774	3364
228,2	291	1,9	12,75	S082	132M/132SB	2	12087	3453
228,2	291	2,6	12,75	S102	132M/132SB	2	15117	4319
208,0	319	2,8	13,99	S102	132M/132SB	2	15537	4439
207,2	320	1,8	14,04	S082	132M/132SB	2	12413	3547
197,6	348	1,6	7,34	S082	132MA/132M	4	12535	3581
188,6	352	1,6	15,43	S082	132M/132SB	2	12733	3638
188,6	352	2,7	15,43	S102	132M/132SB	2	15989	4568
185,1	359	1,6	15,73	S082	132M/132SB	2	12799	3657
179,8	382	1,6	8,06	S082	132MA/132M	4	12853	3672
179,8	382	2,2	8,06	S102	132MA/132M	4	16177	4622
169,1	392	2,5	17,21	S102	132M/132SB	2	16505	4716
168,3	394	1,5	17,29	S082	132M/132SB	2	13127	3751

7,50 kW

n2 [rpm]	M2 [Nm]	fs	i	Gear reducer	Motor Size	Pole	Fr2 D [N]	Fr2 C-L [N]
163,9	420	2,1	8,85	S102	132MA/132M	4	16615	4747
153,2	433	2,4	19,00	S102	132M/132SB	2	16980	4851
152,9	434	1,3	19,03	S082	132M/132SB	2	13459	3845
145,8	472	1,4	9,94	S082	132MA/132M	4	13571	3877
144,5	459	1,3	20,14	S082	132M/132SB	2	13657	3902
139,7	475	2,2	20,83	S102	132M/132SB	2	17429	4980
133,2	516	1,8	10,88	S102	132MA/132M	4	17617	5034
132,6	524	3,8	7,32	S142	160M	6	35000	18500
131,5	504	1,2	22,13	S082	132M/132SB	2	13986	3996
131,5	504	2,1	22,13	S102	132M/132SB	2	17728	5065
127,1	541	3,8	11,41	S142	132MA/132M	4	35000	18500
124,9	550	1,3	11,61	S082	132MA/132M	4	14103	4029
121,3	547	1,1	24,00	S082	132M/132SB	2	14272	4078
120,3	577	1,5	8,06	S102	160M	6	18107	5174
119,9	554	2,0	24,28	S102	132M/132SB	2	18192	5198
118,2	588	3,8	8,21	S142	160M	6	35000	18500
114,4	607	2,6	8,48	S122	160M	6	26221	7492
113,7	605	1,2	12,75	S082	132MA/132M	4	14426	4122
113,7	605	1,7	12,75	S102	132MA/132M	4	18404	5258
113,2	608	3,1	12,81	S142	132MA/132M	4	35000	18500
111,7	594	1,0	26,05	S082	132M/132SB	2	14558	4159
111,3	596	3,8	26,15	S122	132M/132SB	2	26522	7578
110,5	600	1,9	26,33	S102	132M/132SB	2	18605	5316
109,6	633	1,5	8,85	S102	160M	6	18571	5306
106,6	622	1,1	27,29	S082	132M/132SB	2	14721	4206
104,5	665	3,8	9,29	S142	160M	6	35000	18500
104,3	666	2,7	9,30	S122	160M	6	26877	7679
103,6	663	1,8	13,99	S102	132MA/132M	4	18872	5392
103,2	666	1,1	14,04	S082	132MA/132M	4	14757	4216
101,7	652	3,5	28,60	S122	132M/132SB	2	27173	7764
101,6	677	2,6	14,27	S142	132MA/132M	4	35000	18500
101,5	654	1,0	28,67	S082	132M/132SB	2	14893	4255
98,3	675	1,0	29,60	S082	132M/132SB	2	15004	4287
97,8	710	3,8	9,91	S142	160M	6	35000	18500
97,4	681	1,7	29,87	S102	132M/132SB	2	19251	5500
95,4	696	3,2	30,51	S122	132M/132SB	2	27647	7899
94,7	733	2,4	10,24	S122	160M	6	27572	7878
94,0	732	1,1	15,43	S082	132MA/132M	4	15075	4307
94,0	732	1,7	15,43	S102	132MA/132M	4	19371	5535
92,2	746	1,0	15,73	S082	132MA/132M	4	15139	4325
91,6	725	1,0	31,78	S082	132M/132SB	2	15248	4357
90,6	759	2,6	16,01	S142	132MA/132M	4	35000	18500

7,50 kW

n2 [rpm]	M2 [Nm]	fs	i	Gear reducer	Motor Size	Pole	Fr2 D [N]	Fr2 C-L [N]
89,8	739	1,5	32,40	S102	132M/132SB	2	19674	5621
89,1	779	1,3	10,88	S102	160M	6	19624	5607
88,8	747	3,0	32,76	S122	132M/132SB	2	28171	8049
87,0	763	3,0	33,44	S122	132M/132SB	2	28325	8093
85,0	817	2,4	11,42	S122	160M	6	28363	8104
85,0	817	3,6	11,41	S142	160M	6	35000	18500
84,2	816	1,6	17,21	S102	132MA/132M	4	19934	5695
83,8	820	0,9	17,29	SO82	132MA/132M	4	15456	4416
83,4	796	1,3	34,91	S102	132M/132SB	2	20063	5732
82,7	803	2,8	35,20	S122	132M/132SB	2	28705	8201
80,1	859	2,6	18,11	S142	132MA/132M	4	35000	18500
77,8	892	3,9	12,46	S152	160M	6	40000	19400
76,8	904	2,6	12,63	S122	160M	6	29098	8314
76,3	901	1,6	19,00	S102	132MA/132M	4	20445	5841
76,1	913	1,2	12,75	S102	160M	6	20437	5839
76,0	873	1,3	38,30	S102	132M/132SB	2	20550	5871
75,7	917	3,0	12,81	S142	160M	6	35000	18500
75,0	917	2,6	19,33	S142	132MA/132M	4	35000	18500
70,9	936	2,4	41,07	S122	132M/132SB	2	29855	8530
70,1	991	2,5	13,84	S122	160M	6	29769	8505
69,7	996	3,9	13,91	S152	160M	6	40000	19400
69,6	988	1,4	20,83	S102	132MA/132M	4	20921	5977
69,3	1002	1,3	13,99	S102	160M	6	20916	5976
68,4	970	1,1	42,53	S102	132M/132SB	2	21101	6029
68,2	1008	2,8	21,25	S122	132MA/132M	4	30000	8572
68,0	1022	2,5	14,27	S142	160M	6	35000	18500
66,7	994	2,3	43,60	S122	132M/132SB	2	30000	8658
65,5	1049	1,3	22,13	S102	132MA/132M	4	21234	6067
65,2	1018	1,8	44,63	S122	132M/132SB	2	30000	8708
65,2	1055	2,3	22,24	S142	132MA/132M	4	35000	18500
64,8	1061	2,6	22,37	S122	132MA/132M	4	30000	8680
62,3	1105	2,6	23,29	S122	132MA/132M	4	30000	8765
61,7	1075	1,1	47,13	S102	132M/132SB	2	21644	6184
60,7	1143	3,9	15,97	S152	160M	6	40000	19400
60,6	1146	2,4	16,01	S142	160M	6	35000	18500
59,7	1151	1,3	24,28	S102	132MA/132M	4	21714	6204
59,3	1118	1,6	49,04	S122	132M/132SB	2	30000	8909
57,4	1198	1,8	25,26	S142	132MA/132M	4	35000	18500
57,1	1217	2,2	16,99	S122	160M	6	30000	8932
56,4	1232	1,1	17,21	S102	160M	6	21982	6281
55,4	1240	2,4	26,15	S122	132MA/132M	4	30000	9006
55,3	1255	3,9	17,53	S152	160M	6	40000	19400

7,50 kW

n ₂ [rpm]	M ₂ [Nm]	f _s	i	Gear reducer	Motor Size	Pole	Fr ₂ D [N]	Fr ₂ C-L [N]
55,1	1249	1,2	26,33	S102	132MA/132M	4	22000	6324
54,1	1226	1,6	53,75	S122	132M/132SB	2	30000	9103
53,6	1296	2,4	18,11	S142	160M	6	35000	18500
51,2	1344	1,8	28,33	S142	132MA/132M	4	35000	18500
50,7	1356	2,2	28,60	S122	132MA/132M	4	30000	9190
50,2	1384	2,4	19,33	S142	160M	6	35000	18500
48,7	1425	3,9	19,91	S152	160M	6	40000	19400
48,5	1416	1,1	29,87	S102	132MA/132M	4	22000	6507
47,5	1447	2,1	30,51	S122	132MA/132M	4	30000	9322
45,6	1521	1,9	21,25	S122	160M	6	30000	9387
45,2	1520	1,8	32,05	S142	132MA/132M	4	35000	18500
44,9	1448	1,4	64,84	S123	132M/132SB	2	30000	9529
44,8	1536	1,0	32,40	S102	132MA/132M	4	22000	6624
44,3	1553	1,9	32,76	S122	132MA/132M	4	30000	9465
44,1	1505	1,5	66,00	S122	132M/132SB	2	30000	9532
43,6	1593	2,2	22,24	S142	160M	6	35000	18500
43,4	1601	1,8	22,37	S122	160M	6	30000	9489
43,4	1586	1,9	33,44	S122	132MA/132M	4	30000	9507
42,4	1623	1,8	34,22	S142	132MA/132M	4	35000	18500
42,4	1638	3,9	22,88	S152	160M	6	40000	19400
41,6	1668	1,8	23,29	S122	160M	6	30000	9568
41,2	1669	1,8	35,20	S122	132MA/132M	4	30000	9608
40,9	1587	1,3	71,07	S123	132M/132SB	2	30000	9719
38,4	1809	1,7	25,26	S142	160M	6	35000	18500
37,1	1872	1,7	26,15	S122	160M	6	30000	9790
37,1	1752	1,3	78,46	S123	132M/132SB	2	30000	9920
36,8	1867	2,4	39,38	S142	132MA/132M	4	35000	18500
36,2	1862	3,4	40,10	S153	132MA/132M	4	40000	19400
35,8	1941	3,3	27,11	S152	160M	6	40000	19400
35,3	1947	1,5	41,07	S122	132MA/132M	4	30000	9902
34,2	2029	1,7	28,33	S142	160M	6	35000	18500
33,9	2048	1,5	28,60	S122	160M	6	30000	9954
33,3	2067	1,5	43,60	S122	132MA/132M	4	30000	10012
33,3	1948	1,2	87,27	S123	132M/132SB	2	30000	10130
32,6	2130	3,3	29,75	S152	160M	6	40000	19400
32,5	2116	1,1	44,63	S122	132MA/132M	4	30000	10053
32,4	2078	3,4	44,76	S153	132MA/132M	4	40000	19400
31,8	2185	1,4	30,51	S122	160M	6	30000	10069
31,7	2125	1,9	45,77	S143	132MA/132M	4	35000	18500
30,3	2295	1,7	32,05	S142	160M	6	35000	18500
29,6	2345	1,3	32,76	S122	160M	6	30000	10189
29,6	2325	1,0	49,04	S122	132MA/132M	4	30000	10217

7,50 kW

n2 [rpm]	M2 [Nm]	fs	i	Gear reducer	Motor Size	Pole	Fr2 D [N]	Fr2 C-L [N]
29,0	2394	1,3	33,44	S122	160M	6	30000	10224
28,7	2419	3,3	33,79	S152	160M	6	40000	19400
28,4	2367	1,9	50,97	S143	132MA/132M	4	35000	18500
28,3	2450	1,7	34,22	S142	160M	6	35000	18500
28,2	2386	3,3	51,38	S153	132MA/132M	4	40000	19400
27,6	2520	1,2	35,20	S122	160M	6	30000	10306
27,0	2549	1,0	53,75	S122	132MA/132M	4	30000	10367
25,7	2619	3,2	56,39	S153	132MA/132M	4	40000	19400
25,4	2655	1,8	57,17	S143	132MA/132M	4	35000	18500
25,0	2781	2,9	38,84	S152	160M	6	40000	19400
24,6	2819	1,7	39,38	S142	160M	6	35000	18500
24,2	2811	2,3	40,10	S153	160M	6	40000	19400
23,6	2940	1,1	41,07	S122	160M	6	30000	10531
22,6	2974	3,0	64,05	S153	132MA/132M	4	40000	19400
22,5	2990	0,9	64,84	S123	132MA/132M	4	30000	10696
22,4	3003	1,6	64,68	S143	132MA/132M	4	35000	18500
22,0	3130	1,0	66,00	S122	132MA/132M	4	30000	10658
21,7	3138	2,3	44,76	S153	160M	6	40000	19400
21,2	3208	1,3	45,77	S143	160M	6	35000	18500
21,0	3206	1,5	69,06	S143	132MA/132M	4	35000	18500
19,7	3419	2,3	73,63	S153	132MA/132M	4	40000	19400
19,0	3573	1,3	50,97	S143	160M	6	35000	18500
18,9	3602	2,3	51,38	S153	160M	6	40000	19400
18,2	3689	1,1	79,45	S143	132MA/132M	4	35000	18500
17,2	3953	2,2	56,39	S153	160M	6	40000	19400
17,0	4008	1,2	57,17	S143	160M	6	35000	18500
16,6	4047	1,8	87,16	S153	132MA/132M	4	40000	19400
15,1	4490	2,1	64,05	S153	160M	6	40000	19400
15,0	4534	1,1	64,68	S143	160M	6	35000	18500
14,9	4517	1,8	97,27	S153	132MA/132M	4	40000	19400
14,7	4588	1,0	98,81	S143	132MA/132M	4	35000	18500
14,0	4841	1,1	69,06	S143	160M	6	35000	18500
13,2	5110	0,9	110,05	S143	132MA/132M	4	35000	18500
13,2	5161	1,6	73,63	S153	160M	6	40000	19400
13,0	5185	1,8	111,67	S153	132MA/132M	4	40000	19400
11,8	5691	1,7	122,57	S153	132MA/132M	4	40000	19400
11,1	6110	1,2	87,16	S153	160M	6	40000	19400
10,4	6464	1,4	139,21	S153	132MA/132M	4	40000	19400
10,0	6819	1,2	97,27	S153	160M	6	40000	19400
9,4	7151	1,0	154,02	S153	132MA/132M	4	40000	19400
9,1	7430	1,1	160,02	S153	132MA/132M	4	40000	19400
8,7	7829	1,2	111,67	S153	160M	6	40000	19400

7,50 kW

n2 [rpm]	M2 [Nm]	fs	i	Gear reducer	Motor Size	Pole	Fr2 D [N]	Fr2 C-L [N]
8,2	8210	1,0	176,81	S153	132MA/132M	4	40000	19400
7,9	8592	1,2	122,57	S153	160M	6	40000	19400
7,5	9011	1,0	194,06	S153	132MA/132M	4	40000	19400
7,0	9759	1,0	139,21	S153	160M	6	40000	19400
6,6	10235	0,9	220,42	S153	132MA/132M	4	40000	19400

9,20 kW

n2 [rpm]	M2 [Nm]	fs	i	Gear reducer	Motor Size	Pole	Fr2 D [N]	Fr2 C-L [N]
396,5	205	2,0	7,34	S082	132M/132MA	2	10195	2913
360,9	226	2,0	8,06	S082	132M/132MA	2	10471	2992
360,9	226	2,8	8,06	S102	132M/132MA	2	13058	3731
328,9	247	2,7	8,85	S102	132M/132MA	2	13426	3836
292,6	278	1,8	9,94	S082	132M/132MA	2	11101	3172
267,4	304	2,3	10,88	S102	132M/132MA	2	14274	4078
250,7	325	1,6	11,61	S082	132M/132MA	2	11577	3308
228,2	357	1,6	12,75	S082	132M/132MA	2	11871	3392
228,2	357	2,1	12,75	S102	132M/132MA	2	14946	4270
208,0	391	2,3	13,99	S102	132M/132MA	2	15349	4385
207,2	393	1,5	14,04	S082	132M/132MA	2	12174	3478
198,2	426	3,3	7,32	S142	132MB	4	34533	18500
197,6	427	1,3	7,34	S082	132MB	4	12275	3507
188,6	432	1,3	15,43	S082	132M/132MA	2	12471	3563
188,6	432	2,2	15,43	S102	132M/132MA	2	15782	4509
185,1	440	1,3	15,73	S082	132M/132MA	2	12532	3580
179,8	469	1,3	8,06	S082	132MB	4	12568	3591
179,8	469	1,8	8,06	S102	132MB	4	15952	4558
176,7	477	3,3	8,21	S142	132MB	4	35000	18500
169,1	481	2,0	17,21	S102	132M/132MA	2	16274	4650
168,3	484	1,2	17,29	S082	132M/132MA	2	12833	3667
163,9	515	1,7	8,85	S102	132MB	4	16368	4677
156,2	540	3,3	9,29	S142	132MB	4	35000	18500
153,2	531	2,0	19,00	S102	132M/132MA	2	16725	4779
152,9	532	1,1	19,03	S082	132M/132MA	2	13136	3753
146,3	577	3,3	9,91	S142	132MB	4	35000	18500
145,8	578	1,1	9,94	S082	132MB	4	13220	3777
144,5	563	1,0	20,14	S082	132M/132MA	2	13315	3804
139,7	583	1,8	20,83	S102	132M/132MA	2	17150	4900
136,9	594	3,5	21,25	S122	132M/132MA	2	24623	7035
133,2	633	1,5	10,88	S102	132MB	4	17314	4947
131,5	619	1,7	22,13	S102	132M/132MA	2	17431	4980
130,1	626	3,4	22,37	S122	132M/132MA	2	24963	7132

9,20 kW

n2 [rpm]	M2 [Nm]	fs	i	Gear reducer	Motor Size	Pole	Fr2 D [N]	Fr2 C-L [N]
127,1	663	3,1	11,41	S142	132MB	4	35000	18500
124,9	675	1,0	11,61	S082	132MB	4	13693	3912
124,9	651	3,3	23,29	S122	132M/132MA	2	25233	7209
119,9	679	1,7	24,28	S102	132M/132MA	2	17867	5105
113,7	742	1,0	12,75	S082	132MB	4	13976	3993
113,7	742	1,3	12,75	S102	132MB	4	18048	5157
113,2	745	2,6	12,81	S142	132MB	4	35000	18500
111,3	732	3,1	26,15	S122	132M/132MA	2	26010	7431
110,5	737	1,5	26,33	S102	132M/132MA	2	18252	5215
103,6	814	1,5	13,99	S102	132MB	4	18482	5281
103,2	817	0,9	14,04	S082	132MB	4	14261	4075
101,7	800	2,8	28,60	S122	132M/132MA	2	26613	7604
101,6	830	2,1	14,27	S142	132MB	4	35000	18500
97,4	835	1,3	29,87	S102	132M/132MA	2	18851	5386
95,4	853	2,6	30,51	S122	132M/132MA	2	27050	7729
94,0	897	1,4	15,43	S102	132MB	4	18941	5412
90,6	931	2,1	16,01	S142	132MB	4	35000	18500
89,8	906	1,2	32,40	S102	132M/132MA	2	19239	5497
88,8	916	2,5	32,76	S122	132M/132MA	2	27530	7866
87,0	935	2,4	33,44	S122	132M/132MA	2	27670	7906
84,2	1001	1,3	17,21	S102	132MB	4	19454	5558
83,4	976	1,1	34,91	S102	132M/132MA	2	19595	5599
82,7	985	2,3	35,20	S122	132M/132MA	2	28016	8004
80,1	1053	2,1	18,11	S142	132MB	4	35000	18500
76,3	1105	1,3	19,00	S102	132MB	4	19915	5690
76,0	1071	1,1	38,30	S102	132M/132MA	2	20036	5725
75,0	1125	2,1	19,33	S142	132MB	4	35000	18500
70,9	1149	2,0	41,07	S122	132M/132MA	2	29051	8300
69,6	1212	1,2	20,83	S102	132MB	4	20340	5811
68,2	1236	2,3	21,25	S122	132MB	4	29138	8325
66,7	1219	1,8	43,60	S122	132M/132MA	2	29448	8414
65,5	1287	1,1	22,13	S102	132MB	4	20617	5891
65,2	1248	1,4	44,63	S122	132M/132MA	2	29603	8458
65,2	1294	1,9	22,24	S142	132MB	4	35000	18500
64,8	1301	2,2	22,37	S122	132MB	4	29468	8420
62,3	1355	2,1	23,29	S122	132MB	4	29728	8494
59,7	1412	1,1	24,28	S102	132MB	4	21037	6011
59,3	1372	1,3	49,04	S122	132M/132MA	2	30000	8634
57,4	1469	1,4	25,26	S142	132MB	4	35000	18500
55,4	1521	2,0	26,15	S122	132MB	4	30000	8702
55,1	1532	1,0	26,33	S102	132MB	4	21399	6114
54,1	1503	1,3	53,75	S122	132M/132MA	2	30000	8803

9,20 kW

n2 [rpm]	M2 [Nm]	fs	i	Gear reducer	Size	Motor	Pole	Fr2 D [N]	Fr2 C-L [N]
51,2	1648	1,4	28,33	S142	132MB		4	35000	18500
50,7	1664	1,8	28,60	S122	132MB		4	30000	8858
47,5	1775	1,7	30,51	S122	132MB		4	30000	8967
45,2	1864	1,4	32,05	S142	132MB		4	35000	18500
44,9	1776	1,1	64,84	S123	132M/132MA		2	30000	9174
44,3	1905	1,6	32,76	S122	132MB		4	30000	9084
44,1	1846	1,2	66,00	S122	132M/132MA		2	30000	9163
43,4	1945	1,5	33,44	S122	132MB		4	30000	9117
42,4	1991	1,4	34,22	S142	132MB		4	35000	18500
41,2	2048	1,5	35,20	S122	132MB		4	30000	9198
40,9	1946	1,0	71,07	S123	132M/132MA		2	30000	9330
37,1	2149	1,0	78,46	S123	132M/132MA		2	30000	9491
36,8	2290	1,9	39,38	S142	132MB		4	35000	18500
36,2	2284	2,7	40,10	S153	132MB		4	40000	19400
35,3	2389	1,3	41,07	S122	132MB		4	30000	9424
33,3	2536	1,2	43,60	S122	132MB		4	30000	9504
32,5	2596	0,9	44,63	S122	132MB		4	30000	9534
32,4	2549	2,7	44,76	S153	132MB		4	40000	19400
31,7	2607	1,5	45,77	S143	132MB		4	35000	18500
28,4	2903	1,5	50,97	S143	132MB		4	35000	18500
28,2	2927	2,7	51,38	S153	132MB		4	40000	19400
25,7	3212	2,6	56,39	S153	132MB		4	40000	19400
25,4	3256	1,5	57,17	S143	132MB		4	35000	18500
22,6	3648	2,4	64,05	S153	132MB		4	40000	19400
22,4	3684	1,3	64,68	S143	132MB		4	35000	18500
21,0	3933	1,2	69,06	S143	132MB		4	35000	18500
19,7	4194	1,9	73,63	S153	132MB		4	40000	19400
18,2	4525	0,9	79,45	S143	132MB		4	35000	18500
16,6	4964	1,4	87,16	S153	132MB		4	40000	19400
14,9	5541	1,4	97,27	S153	132MB		4	40000	19400
13,0	6361	1,4	111,67	S153	132MB		4	40000	19400
11,8	6981	1,4	122,57	S153	132MB		4	40000	19400
10,4	7929	1,2	139,21	S153	132MB		4	40000	19400

11,00 kW

n2 [rpm]	M2 [Nm]	fs	i	Gear reducer	Size	Motor	Pole	Fr2 D [N]	Fr2 C-L [N]
396,5	245	1,7	7,34	S082	132MB ⁽¹⁾		2	10063	2875
360,9	270	1,7	8,06	S082	132MB ⁽¹⁾		2	10326	2950
360,9	270	2,4	8,06	S102	132MB ⁽¹⁾		2	12944	3698
349,7	288	3,5	4,12	S142	132MC ⁽¹⁾		4	29139	16651
328,9	296	2,3	8,85	S102	132MB ⁽¹⁾		2	13300	3800

⁽¹⁾ Available only with brake motor (TBS)

11,00 kW

n2 [rpm]	M2 [Nm]	fs	i	Gear reducer	Motor Size	Pole	Fr2 D [N]	Fr2 C-L [N]
314,0	321	3,5	4,59	S142	132MC ⁽¹⁾	4	30017	17153
292,6	333	1,5	9,94	S082	132MB ⁽¹⁾	2	10922	3121
279,9	360	3,5	5,14	S142	132MC ⁽¹⁾	4	30966	17695
267,4	364	2,0	10,88	S102	132MB ⁽¹⁾	2	14119	4034
250,7	388	1,4	11,61	S082	132MB ⁽¹⁾	2	11369	3248
247,5	408	3,5	5,82	S142	132MC ⁽¹⁾	4	31997	18284
235,6	432	3,4	4,12	S142	160L	6	32378	18500
231,8	435	3,5	6,21	S142	132MC ⁽¹⁾	4	32549	18500
228,2	426	1,3	12,75	S082	132MB ⁽¹⁾	2	11641	3326
228,2	426	1,8	12,75	S102	132MB ⁽¹⁾	2	14765	4218
211,5	482	3,4	4,59	S142	160L	6	33285	18500
208,0	468	1,9	13,99	S102	132MB ⁽¹⁾	2	15150	4329
207,2	470	1,2	14,04	S082	132MB ⁽¹⁾	2	11922	3406
196,8	512	3,7	7,32	S142	132MC/160MA/160S	4	33935	18500
196,2	514	1,1	7,34	S082	132MC ⁽¹⁾	4	12021	3434
188,6	516	1,1	15,43	S082	132MB ⁽¹⁾	2	12194	3484
188,6	516	1,8	15,43	S102	132MB ⁽¹⁾	2	15563	4447
188,6	540	3,4	5,14	S142	160L	6	34255	18500
185,1	526	1,1	15,73	S082	132MB ⁽¹⁾	2	12249	3500
178,6	565	1,1	8,06	S082	132MC ⁽¹⁾	4	12286	3510
178,6	565	1,5	8,06	S102	132MC/160MA/160S	4	15743	4498
175,4	575	3,7	8,21	S142	132MC/160MA/160S	4	34910	18500
169,8	594	2,5	8,48	S122	160MA/160S	4	22785	6510
169,1	576	1,7	17,21	S102	132MB ⁽¹⁾	2	16029	4580
166,7	611	3,4	5,82	S142	160L	6	35000	18500
162,8	620	1,5	8,85	S102	132MC/160MA/160S	4	16136	4610
156,1	652	3,4	6,21	S142	160L	6	35000	18500
155,1	650	3,7	9,29	S142	132MC/160MA/160S	4	35000	18500
154,9	651	2,6	9,30	S122	160MA/160S	4	23338	6668
153,2	635	1,7	19,00	S102	132MB ⁽¹⁾	2	16455	4701
145,3	694	3,7	9,91	S142	132MC/160MA/160S	4	35000	18500
144,8	696	0,9	9,94	S082	132MC ⁽¹⁾	4	12867	3676
140,7	717	2,4	10,24	S122	160MA/160S	4	23923	6835
139,7	697	1,5	20,83	S102	132MB ⁽¹⁾	2	16854	4815
136,9	711	3,0	21,25	S122	132MB ⁽¹⁾	2	24183	6909
132,6	768	2,6	7,32	S142	160L	6	35000	18500
132,3	762	1,2	10,88	S102	132MC/160MA/160S	4	17022	4863
131,5	740	1,4	22,13	S102	132MB ⁽¹⁾	2	17117	4891
130,1	748	2,8	22,37	S122	132MB ⁽¹⁾	2	24500	7000
126,2	799	3,5	11,41	S142	132MC/160MA/160S	4	35000	18500
126,1	800	2,4	11,42	S122	160MA/160S	4	24585	7024
124,9	779	2,8	23,29	S122	132MB ⁽¹⁾	2	24750	7072

⁽¹⁾ Available only with brake motor (TBS)

11,00 kW

n2 [rpm]	M2 [Nm]	fs	i	Gear reducer	Motor Size	Pole	Fr2 D [N]	Fr2 C-L [N]
120,3	847	1,1	8,06	S102	160L	6	17408	4974
119,9	812	1,4	24,28	S102	132MB ⁽¹⁾	2	17522	5006
118,2	862	2,6	8,21	S142	160L	6	35000	18500
115,5	873	3,8	12,46	S152	160MA/160S	4	40000	19400
114,4	891	1,8	8,48	S122	160L	6	25148	7185
114,1	884	2,5	12,63	S122	160MA/160S	4	25197	7199
112,9	893	1,1	12,75	S102	132MC/160MA/160S	4	17701	5057
112,4	897	2,9	12,81	S142	132MC/160MA/160S	4	35000	18500
111,3	875	2,6	26,15	S122	132MB ⁽¹⁾	2	25468	7276
110,5	881	1,3	26,33	S102	132MB ⁽¹⁾	2	17878	5108
109,6	929	1,0	8,85	S102	160L	6	17804	5087
104,5	975	2,6	9,29	S142	160L	6	35000	18500
104,3	976	1,8	9,30	S122	160L	6	25700	7343
104,1	969	2,5	13,84	S122	160MA/160S	4	25753	7358
103,5	974	3,8	13,91	S152	160MA/160S	4	40000	19400
102,9	980	1,2	13,99	S102	132MC/160MA/160S	4	18098	5171
101,7	956	2,4	28,60	S122	132MB ⁽¹⁾	2	26020	7434
100,9	999	2,4	14,27	S142	132MC/160MA/160S	4	35000	18500
97,8	1041	2,6	9,91	S142	160L	6	35000	18500
97,4	999	1,1	29,87	S102	132MB ⁽¹⁾	2	18427	5265
95,4	1020	2,2	30,51	S122	132MB ⁽¹⁾	2	26417	7548
94,7	1075	1,7	10,24	S122	160L	6	26276	7508
93,3	1081	1,2	15,43	S102	132MC ⁽¹⁾	4	18515	5290
90,2	1118	3,8	15,97	S152	160MA/160S	4	40000	19400
90,0	1121	2,4	16,01	S142	132MC/160MA/160S	4	35000	18500
89,8	1084	1,0	32,40	S102	132MB ⁽¹⁾	2	18779	5365
88,8	1095	2,1	32,76	S122	132MB ⁽¹⁾	2	26850	7672
87,0	1118	2,0	33,44	S122	132MB ⁽¹⁾	2	26977	7708
85,0	1199	1,7	11,42	S122	160L	6	26918	7691
85,0	1198	2,5	11,41	S142	160L	6	35000	18500
84,7	1190	2,2	16,99	S122	160MA/160S	4	26979	7708
83,7	1205	1,1	17,21	S102	132MC/160MA/160S	4	18974	5421
82,7	1177	1,9	35,20	S122	132MB ⁽¹⁾	2	27286	7796
82,2	1227	3,8	17,53	S152	160MA/160S	4	40000	19400
79,5	1268	2,4	18,11	S142	132MC/160MA/160S	4	35000	18500
77,8	1309	2,7	12,46	S152	160L	6	40000	19400
76,8	1326	1,7	12,63	S122	160L	6	27500	7857
75,8	1331	1,1	19,00	S102	132MC ⁽¹⁾	4	19382	5538
75,7	1345	2,0	12,81	S142	160L	6	35000	18500
74,5	1354	2,4	19,33	S142	132MC/160MA/160S	4	35000	18500
72,3	1394	3,8	19,91	S152	160MA/160S	4	40000	19400
70,9	1373	1,6	41,07	S122	132MB ⁽¹⁾	2	28199	8057

⁽¹⁾ Available only with brake motor (TBS)

11,00 kW

n2 [rpm]	M2 [Nm]	fs	i	Gear reducer	Motor Size	Pole	Fr2 D [N]	Fr2 C-L [N]
70,1	1453	1,7	13,84	S122	160L	6	28017	8005
69,7	1461	2,7	13,91	S152	160L	6	40000	19400
69,1	1459	1,0	20,83	S102	132MC ⁽¹⁾	4	19752	5644
68,0	1499	1,7	14,27	S142	160L	6	35000	18500
67,8	1488	1,9	21,25	S122	132MC/160MA/160S	4	28260	8074
66,7	1458	1,5	43,60	S122	132MB ⁽¹⁾	2	28544	8156
65,2	1493	1,2	44,63	S122	132MB ⁽¹⁾	2	28678	8194
65,1	1549	0,9	22,13	S102	132MC ⁽¹⁾	4	19991	5712
64,7	1558	2,1	22,24	S142	132MC/160MA/160S	4	35000	18500
64,4	1566	1,8	22,37	S122	132MC/160MA/160S	4	28542	8155
62,9	1602	3,8	22,88	S152	160MA/160S	4	40000	19400
61,8	1631	1,8	23,29	S122	132MC/160MA/160S	4	28761	8217
60,7	1677	2,7	15,97	S152	160L	6	40000	19400
60,6	1681	1,7	16,01	S142	160L	6	35000	18500
59,3	1640	1,1	49,04	S122	132MB ⁽¹⁾	2	29203	8344
57,1	1784	1,5	16,99	S122	160L	6	29113	8318
57,0	1769	1,6	25,26	S142	132MC/160MA/160S	4	35000	18500
55,3	1840	2,7	17,53	S152	160L	6	40000	19400
55,1	1832	1,6	26,15	S122	132MC/160MA/160S	4	29364	8390
54,1	1798	1,1	53,75	S122	132MB ⁽¹⁾	2	29695	8484
53,6	1901	1,7	18,11	S142	160L	6	35000	18500
53,1	1898	3,2	27,11	S152	160MA/160S	4	40000	19400
50,8	1984	1,6	28,33	S142	132MC/160MA/160S	4	35000	18500
50,3	2003	1,5	28,60	S122	132MC/160MA/160S	4	29802	8515
50,2	2030	1,7	19,33	S142	160L	6	35000	18500
48,7	2090	2,7	19,91	S152	160L	6	40000	19400
48,4	2083	3,2	29,75	S152	160MA/160S	4	40000	19400
47,2	2137	1,4	30,51	S122	132MC/160MA/160S	4	30000	8600
45,6	2231	1,3	21,25	S122	160L	6	30000	8619
44,9	2245	1,6	32,05	S142	132MC/160MA/160S	4	35000	18500
44,1	2207	1,0	66,00	S122	132MB ⁽¹⁾	2	30000	8772
44,0	2294	1,3	32,76	S122	132MC/160MA/160S	4	30000	8689
43,6	2336	1,5	22,24	S142	160L	6	35000	18500
43,4	2349	1,3	22,37	S122	160L	6	30000	8680
43,1	2342	1,3	33,44	S122	132MC/160MA/160S	4	30000	8714
42,6	2366	3,2	33,79	S152	160MA/160S	4	40000	19400
42,4	2403	2,7	22,88	S152	160L	6	40000	19400
42,1	2397	1,6	34,22	S142	132MC/160MA/160S	4	35000	18500
41,6	2446	1,2	23,29	S122	160L	6	30000	8726
40,9	2465	1,2	35,20	S122	132MC/160MA/160S	4	30000	8772
38,4	2653	1,1	25,26	S142	160L	6	35000	18500
37,1	2746	1,1	26,15	S122	160L	6	30000	8844

⁽¹⁾ Available only with brake motor (TBS)

11,00 kW

n2 [rpm]	M2 [Nm]	fs	i	Gear reducer	Motor Size	Pole	Fr2 D [N]	Fr2 C-L [N]
37,1	2720	2,8	38,84	S152	160MA/160S	4	40000	19400
36,6	2758	1,6	39,38	S142	132MC/160MA/160S	4	35000	18500
35,9	2750	2,3	40,10	S153	132MC/160MA/160S	4	40000	19400
35,8	2846	2,2	27,11	S152	160L	6	40000	19400
35,1	2876	1,0	41,07	S122	132MC/160MA/160S	4	30000	8924
34,2	2975	1,1	28,33	S142	160L	6	35000	18500
33,9	3003	1,0	28,60	S122	160L	6	30000	8920
33,0	3053	1,0	43,60	S122	132MC ⁽¹⁾	4	30000	8973
32,6	3124	2,2	29,75	S152	160L	6	40000	19400
32,2	3069	2,3	44,76	S153	132MC/160MA/160S	4	40000	19400
31,8	3204	1,0	30,51	S122	160L	6	30000	8965
31,5	3138	1,3	45,77	S143	132MC/160MA/160S	4	35000	18500
30,3	3366	1,1	32,05	S142	160L	6	35000	18500
29,6	3440	0,9	32,76	S122	160L	6	30000	9005
28,7	3548	2,2	33,79	S152	160L	6	40000	19400
28,3	3594	1,1	34,22	S142	160L	6	35000	18500
28,3	3495	1,3	50,97	S143	132MC/160MA/160S	4	35000	18500
28,0	3523	2,2	51,38	S153	132MC/160MA/160S	4	40000	19400
25,5	3867	2,1	56,39	S153	132MC/160MA/160S	4	40000	19400
25,2	3921	1,2	57,17	S143	132MC/160MA/160S	4	35000	18500
25,0	4078	2,0	38,84	S152	160L	6	40000	19400
24,6	4135	1,1	39,38	S142	160L	6	35000	18500
24,2	4123	1,6	40,10	S153	160L	6	40000	19400
22,5	4392	2,0	64,05	S153	132MC/160MA/160S	4	40000	19400
22,3	4435	1,1	64,68	S143	132MC/160MA/160S	4	35000	18500
21,7	4602	1,6	44,76	S153	160L	6	40000	19400
20,9	4735	1,0	69,06	S143	132MC/160MA/160S	4	35000	18500
19,6	5049	1,5	73,63	S153	132MC/160MA/160S	4	40000	19400
18,9	5283	1,6	51,38	S153	160L	6	40000	19400
17,2	5798	1,5	56,39	S153	160L	6	40000	19400
16,5	5977	1,2	87,16	S153	132MC/160MA/160S	4	40000	19400
15,1	6586	1,4	64,05	S153	160L	6	40000	19400
14,8	6671	1,2	97,27	S153	132MC/160MA/160S	4	40000	19400
13,2	7570	1,1	73,63	S153	160L	6	40000	19400
12,9	7658	1,2	111,67	S153	132MC/160MA/160S	4	40000	19400
11,7	8405	1,1	122,57	S153	132MC/160MA/160S	4	40000	19400
10,3	9546	1,0	139,21	S153	132MC/160MA/160S	4	40000	19400

15,00 kW

n2 [rpm]	M2 [Nm]	fs	i	Gear reducer	Motor Size	Pole	Fr2 D [N]	Fr2 C-L [N]
358,2	384	3,6	4,12	S142	160LA	4	28137	16078

⁽¹⁾ Available only with brake motor (TBS)

15,00 kW

n2 [rpm]	M2 [Nm]	fs	i	Gear reducer	Size	Motor Pole	Fr2 D [N]	Fr2 C-L [N]
321,6	428	3,6	4,59	S142	160LA	4	28921	16526
286,8	480	3,6	5,14	S142	160LA	4	29758	17004
253,5	543	3,6	5,82	S142	160LA	4	30654	17517
238,0	584	2,5	4,12	S142	180L ⁽²⁾	6	31064	17751
237,4	579	3,6	6,21	S142	160LA	4	31128	17787
213,7	650	2,5	4,59	S142	180L ⁽²⁾	6	31832	18190
201,6	682	2,8	7,32	S142	160LA	4	32297	18455
190,5	729	2,5	5,14	S142	180L ⁽²⁾	6	32635	18500
182,9	752	1,1	8,06	S102	160LA	4	15122	4321
179,7	765	2,8	8,21	S142	160LA	4	33097	18500
173,9	791	1,9	8,48	S122	160LA	4	21842	6241
171,6	809	3,8	5,71	S152	180L ⁽²⁾	6	40000	19400
168,4	825	2,5	5,82	S142	180L ⁽²⁾	6	33475	18500
166,7	825	1,1	8,85	S102	160LA	4	15463	4418
158,9	866	2,8	9,29	S142	160LA	4	33930	18500
158,6	867	2,0	9,30	S122	160LA	4	22318	6376
157,7	881	2,5	6,21	S142	180L ⁽²⁾	6	33908	18500
150,2	925	3,5	6,52	S152	180L ⁽²⁾	6	40000	19400
148,8	924	2,8	9,91	S142	160LA	4	34359	18500
144,1	955	1,8	10,24	S122	160LA	4	22813	6518
135,5	1015	0,9	10,88	S102	160LA	4	16217	4633
134,6	1032	3,3	7,28	S152	180L ⁽²⁾	6	40000	19400
133,9	1037	1,9	7,32	S142	180L ⁽²⁾	6	34940	18500
129,3	1063	2,6	11,41	S142	160LA	4	35000	18500
129,2	1064	1,8	11,42	S122	160LA	4	23364	6675
119,4	1163	1,9	8,21	S142	180L ⁽²⁾	6	35000	18500
118,3	1162	2,8	12,46	S152	160LA	4	40000	19400
117,3	1185	3,1	8,36	S152	180L ⁽²⁾	6	40000	19400
116,8	1177	1,9	12,63	S122	160LA	4	23862	6818
115,5	1202	1,3	8,48	S122	180L ⁽²⁾	6	23871	6820
115,1	1195	2,2	12,81	S142	160LA	4	35000	18500
106,8	1300	3,0	9,17	S152	180L ⁽²⁾	6	40000	19400
106,6	1290	1,9	13,84	S122	160LA	4	24305	6944
106,0	1297	2,8	13,91	S152	160LA	4	40000	19400
105,5	1316	1,9	9,29	S142	180L ⁽²⁾	6	35000	18500
105,4	1304	0,9	13,99	S102	160LA	4	17093	4884
105,4	1318	1,4	9,30	S122	180L ⁽²⁾	6	24308	6945
103,4	1331	1,8	14,27	S142	160LA	4	35000	18500
98,9	1405	1,9	9,91	S142	180L ⁽²⁾	6	35000	18500
95,7	1451	1,2	10,24	S122	180L ⁽²⁾	6	24749	7071
94,1	1477	3,0	10,42	S152	180L ⁽²⁾	6	40000	19400
92,4	1489	2,8	15,97	S152	160LA	4	40000	19400

⁽²⁾ With TBS brake motor, please contact our Technical Sales Support

15,00 kW

n2 [rpm]	M2 [Nm]	fs	i	Gear reducer	Motor Size	Pole	Fr2 D [N]	Fr2 C-L [N]
92,2	1492	1,8	16,01	S142	160LA	4	35000	18500
86,8	1584	1,6	16,99	S122	160LA	4	25237	7211
85,9	1617	1,8	11,41	S142	180L ⁽²⁾	6	35000	18500
85,8	1618	1,2	11,42	S122	180L ⁽²⁾	6	25224	7207
84,2	1634	2,8	17,53	S152	160LA	4	40000	19400
81,5	1688	1,8	18,11	S142	160LA	4	35000	18500
78,6	1766	2,0	12,46	S152	180L ⁽²⁾	6	40000	19400
77,6	1789	1,3	12,63	S122	180L ⁽²⁾	6	25634	7324
76,5	1816	1,5	12,81	S142	180L ⁽²⁾	6	35000	18500
76,3	1803	1,8	19,33	S142	160LA	4	35000	18500
74,1	1856	2,8	19,91	S152	160LA	4	40000	19400
70,8	1961	1,3	13,84	S122	180L ⁽²⁾	6	25979	7423
70,5	1971	2,0	13,91	S152	180L ⁽²⁾	6	40000	19400
69,4	1981	1,4	21,25	S122	160LA	4	26125	7464
68,7	2023	1,3	14,27	S142	180L ⁽²⁾	6	35000	18500
66,3	2074	1,6	22,24	S142	160LA	4	35000	18500
65,9	2085	1,3	22,37	S122	160LA	4	26304	7515
64,5	2133	2,8	22,88	S152	160LA	4	40000	19400
63,3	2172	1,3	23,29	S122	160LA	4	26438	7554
61,4	2263	2,0	15,97	S152	180L ⁽²⁾	6	40000	19400
61,2	2269	1,2	16,01	S142	180L ⁽²⁾	6	35000	18500
58,4	2355	1,2	25,26	S142	160LA	4	35000	18500
57,7	2408	1,1	16,99	S122	180L ⁽²⁾	6	26628	7608
56,4	2438	1,2	26,15	S122	160LA	4	26778	7651
55,9	2484	2,0	17,53	S152	180L ⁽²⁾	6	40000	19400
54,4	2527	2,4	27,11	S152	160LA	4	40000	19400
54,1	2566	1,2	18,11	S142	180L ⁽²⁾	6	35000	18500
52,1	2642	1,2	28,33	S142	160LA	4	35000	18500
51,6	2666	1,1	28,60	S122	160LA	4	26993	7712
50,7	2740	1,2	19,33	S142	180L ⁽²⁾	6	35000	18500
49,6	2774	2,4	29,75	S152	160LA	4	40000	19400
49,2	2821	2,0	19,91	S152	180L ⁽²⁾	6	40000	19400
48,3	2845	1,1	30,51	S122	160LA	4	27118	7748
46,1	3012	1,0	21,25	S122	180L ⁽²⁾	6	27079	7737
46,0	2988	1,2	32,05	S142	160LA	4	35000	18500
45,0	3054	1,0	32,76	S122	160LA	4	27224	7778
44,1	3118	1,0	33,44	S122	160LA	4	27248	7785
44,1	3153	1,1	22,24	S142	180L ⁽²⁾	6	35000	18500
43,8	3170	0,9	22,37	S122	180L ⁽²⁾	6	27136	7753
43,7	3150	2,4	33,79	S152	160LA	4	40000	19400
43,1	3191	1,2	34,22	S142	160LA	4	35000	18500
42,8	3243	2,0	22,88	S152	180L ⁽²⁾	6	40000	19400

⁽²⁾ With TBS brake motor, please contact our Technical Sales Support

15,00 kW

n2 [rpm]	M2 [Nm]	fs	i	Gear reducer	Size	Motor Pole	Fr2 D [N]	Fr2 C-L [N]
42,1	3301	0,9	23,29	S122	180L ⁽²⁾	6	27166	7762
41,9	3282	0,9	35,20	S122	160LA	4	27293	7798
38,0	3621	2,1	38,84	S152	160LA	4	40000	19400
37,5	3671	1,2	39,38	S142	160LA	4	35000	18500
36,8	3661	1,7	40,10	S153	160LA	4	40000	19400
36,2	3842	1,7	27,11	S152	180L ⁽²⁾	6	40000	19400
33,0	4086	1,7	44,76	S153	160LA	4	40000	19400
32,9	4216	1,7	29,75	S152	180L ⁽²⁾	6	40000	19400
32,2	4178	1,0	45,77	S143	160LA	4	35000	18500
29,0	4789	1,7	33,79	S152	180L ⁽²⁾	6	40000	19400
28,9	4653	1,0	50,97	S143	160LA	4	34794	18500
28,7	4691	1,7	51,38	S153	160LA	4	40000	19400
26,2	5148	1,6	56,39	S153	160LA	4	40000	19400
25,8	5219	0,9	57,17	S143	160LA	4	33091	18500
25,2	5505	1,5	38,84	S152	180L ⁽²⁾	6	40000	19400
24,4	5565	1,2	40,10	S153	180L ⁽²⁾	6	40000	19400
23,0	5847	1,5	64,05	S153	160LA	4	40000	19400
21,9	6211	1,2	44,76	S153	180L ⁽²⁾	6	40000	19400
20,0	6721	1,2	73,63	S153	160LA	4	40000	19400
19,1	7131	1,2	51,38	S153	180L ⁽²⁾	6	40000	19400
17,4	7826	1,1	56,39	S153	180L ⁽²⁾	6	40000	19400
15,3	8889	1,0	64,05	S153	180L ⁽²⁾	6	40000	19400

18,50 kW

n2 [rpm]	M2 [Nm]	fs	i	Gear reducer	Size	Motor Pole	Fr2 D [N]	Fr2 C-L [N]
357,0	475	2,9	4,12	S142	180M ⁽²⁾	4	27453	15687
320,5	529	2,9	4,59	S142	180M ⁽²⁾	4	28156	16089
285,8	593	2,9	5,14	S142	180M ⁽²⁾	4	28897	16513
252,6	671	2,9	5,82	S142	180M ⁽²⁾	4	29677	16958
241,3	710	3,8	4,06	S152	200LA ⁽²⁾	6	39103	19400
238,0	720	2,0	4,12	S142	200LA ⁽²⁾	6	29990	17137
236,6	717	2,9	6,21	S142	180M ⁽²⁾	4	30083	17190
216,2	792	3,8	4,53	S152	200LA ⁽²⁾	6	40000	19400
213,7	802	2,0	4,59	S142	200LA ⁽²⁾	6	30636	17506
201,9	840	3,9	7,28	S152	180M ⁽²⁾	4	40000	19400
200,9	844	2,3	7,32	S142	180M ⁽²⁾	4	31061	17749
190,5	899	2,0	5,14	S142	200LA ⁽²⁾	6	31294	17882
188,3	910	3,4	5,20	S152	200LA ⁽²⁾	6	40000	19400
179,1	947	2,3	8,21	S142	180M ⁽²⁾	4	31707	18118
175,9	964	3,7	8,36	S152	180M ⁽²⁾	4	40000	19400
173,3	979	1,5	8,48	S122	180M ⁽²⁾	4	21158	6045

⁽²⁾ With TBS brake motor, please contact our Technical Sales Support

18,50 kW

n2 [rpm]	M2 [Nm]	fs	i	Gear reducer	Motor Size	Pole	Fr2 D [N]	Fr2 C-L [N]
171,6	998	3,1	5,71	S152	200LA ⁽²⁾	6	40000	19400
168,4	1017	2,0	5,82	S142	200LA ⁽²⁾	6	31957	18261
160,3	1058	3,5	9,17	S152	180M ⁽²⁾	4	40000	19400
158,3	1071	2,3	9,29	S142	180M ⁽²⁾	4	32354	18488
158,1	1073	1,6	9,30	S122	180M ⁽²⁾	4	21566	6162
157,7	1086	2,0	6,21	S142	200LA ⁽²⁾	6	32288	18450
150,2	1140	2,8	6,52	S152	200LA ⁽²⁾	6	40000	19400
148,3	1144	2,3	9,91	S142	180M ⁽²⁾	4	32674	18500
143,6	1181	1,4	10,24	S122	180M ⁽²⁾	4	21983	6281
141,1	1202	3,5	10,42	S152	180M ⁽²⁾	4	40000	19400
134,6	1273	2,7	7,28	S152	200LA ⁽²⁾	6	40000	19400
133,9	1279	1,6	7,32	S142	200LA ⁽²⁾	6	33032	18500
128,9	1316	2,1	11,41	S142	180M ⁽²⁾	4	33291	18500
128,8	1317	1,4	11,42	S122	180M ⁽²⁾	4	22437	6411
119,4	1435	1,6	8,21	S142	200LA ⁽²⁾	6	33470	18500
117,9	1438	2,3	12,46	S152	180M ⁽²⁾	4	40000	19400
117,3	1461	2,5	8,36	S152	200LA ⁽²⁾	6	40000	19400
116,4	1457	1,5	12,63	S122	180M ⁽²⁾	4	22835	6524
115,5	1483	1,1	8,48	S122	200LA ⁽²⁾	6	22809	6517
114,7	1478	1,8	12,81	S142	180M ⁽²⁾	4	33719	18500
106,8	1603	2,5	9,17	S152	200LA ⁽²⁾	6	40000	19400
106,2	1597	1,5	13,84	S122	180M ⁽²⁾	4	23176	6622
105,7	1605	2,3	13,91	S152	180M ⁽²⁾	4	40000	19400
105,5	1623	1,6	9,29	S142	200LA ⁽²⁾	6	33845	18500
105,4	1625	1,1	9,30	S122	200LA ⁽²⁾	6	23143	6612
103,0	1647	1,5	14,27	S142	180M ⁽²⁾	4	34036	18500
98,9	1733	1,6	9,91	S142	200LA ⁽²⁾	6	33998	18500
95,7	1790	1,0	10,24	S122	200LA ⁽²⁾	6	23467	6705
94,1	1821	2,4	10,42	S152	200LA ⁽²⁾	6	40000	19400
92,1	1842	2,3	15,97	S152	180M ⁽²⁾	4	40000	19400
91,8	1847	1,4	16,01	S142	180M ⁽²⁾	4	34271	18500
86,5	1961	1,3	16,99	S122	180M ⁽²⁾	4	23846	6813
85,9	1994	1,5	11,41	S142	200LA ⁽²⁾	6	34198	18500
85,8	1996	1,0	11,42	S122	200LA ⁽²⁾	6	23794	6798
83,9	2022	2,3	17,53	S152	180M ⁽²⁾	4	40000	19400
81,2	2089	1,4	18,11	S142	180M ⁽²⁾	4	34388	18500
78,6	2179	1,6	12,46	S152	200LA ⁽²⁾	6	40000	19400
77,6	2207	1,0	12,63	S122	200LA ⁽²⁾	6	24052	6872
76,5	2240	1,2	12,81	S142	200LA ⁽²⁾	6	34212	18500
76,0	2231	1,4	19,33	S142	180M ⁽²⁾	4	34384	18500
73,8	2297	2,3	19,91	S152	180M ⁽²⁾	4	40000	19400
70,8	2419	1,0	13,84	S122	200LA ⁽²⁾	6	24245	6927

⁽²⁾ With TBS brake motor, please contact our Technical Sales Support

18,50 kW

n2 [rpm]	M2 [Nm]	fs	i	Gear reducer	Motor Size	Pole	Fr2 D [N]	Fr2 C-L [N]
70,5	2431	1,6	13,91	S152	200LA ⁽²⁾	6	40000	19400
69,2	2452	1,1	21,25	S122	180M ⁽²⁾	4	24380	6966
68,7	2495	1,0	14,27	S142	200LA ⁽²⁾	6	34080	18500
66,1	2567	1,3	22,24	S142	180M ⁽²⁾	4	34198	18500
65,7	2581	1,1	22,37	S122	180M ⁽²⁾	4	24466	6990
64,2	2640	2,3	22,88	S152	180M ⁽²⁾	4	40000	19400
63,1	2687	1,1	23,29	S122	180M ⁽²⁾	4	24523	7006
61,4	2791	1,6	15,97	S152	200LA ⁽²⁾	6	40000	19400
61,2	2798	1,0	16,01	S142	200LA ⁽²⁾	6	33763	18500
58,2	2915	1,0	25,26	S142	180M ⁽²⁾	4	33786	18500
57,7	2970	0,9	16,99	S122	200LA ⁽²⁾	6	24499	7000
56,2	3018	1,0	26,15	S122	180M ⁽²⁾	4	24625	7036
55,9	3064	1,6	17,53	S152	200LA ⁽²⁾	6	40000	19400
54,2	3127	1,9	27,11	S152	180M ⁽²⁾	4	40000	19400
54,1	3165	1,0	18,11	S142	200LA ⁽²⁾	6	33185	18500
51,9	3269	1,0	28,33	S142	180M ⁽²⁾	4	33182	18500
51,4	3300	0,9	28,60	S122	180M ⁽²⁾	4	24635	7039
50,7	3379	1,0	19,33	S142	200LA ⁽²⁾	6	32766	18500
49,4	3433	1,9	29,75	S152	180M ⁽²⁾	4	40000	19400
49,2	3480	1,6	19,91	S152	200LA ⁽²⁾	6	40000	19400
45,9	3698	1,0	32,05	S142	180M ⁽²⁾	4	32248	18427
43,5	3899	1,9	33,79	S152	180M ⁽²⁾	4	40000	19400
43,0	3949	1,0	34,22	S142	180M ⁽²⁾	4	31615	18066
42,8	4000	1,6	22,88	S152	200LA ⁽²⁾	6	40000	19400
37,8	4481	1,7	38,84	S152	180M ⁽²⁾	4	40000	19400
37,3	4543	1,0	39,38	S142	180M ⁽²⁾	4	29900	17085
36,7	4531	1,4	40,10	S153	180M ⁽²⁾	4	40000	19400
36,2	4738	1,3	27,11	S152	200LA ⁽²⁾	6	40000	19400
32,9	5200	1,3	29,75	S152	200LA ⁽²⁾	6	40000	19400
32,8	5056	1,4	44,76	S153	180M ⁽²⁾	4	40000	19400
29,0	5907	1,3	33,79	S152	200LA ⁽²⁾	6	40000	19400
28,6	5805	1,4	51,38	S153	180M ⁽²⁾	4	40000	19400
26,1	6371	1,3	56,39	S153	180M ⁽²⁾	4	40000	19400
25,2	6789	1,2	38,84	S152	200LA ⁽²⁾	6	40000	19400
22,9	7236	1,2	64,05	S153	180M ⁽²⁾	4	40000	19400
20,0	8318	0,9	73,63	S153	180M ⁽²⁾	4	40000	19400

22,00 kW

n2 [rpm]	M2 [Nm]	fs	i	Gear reducer	Motor Size	Pole	Fr2 D [N]	Fr2 C-L [N]
357,0	565	2,5	4,12	S142	180L ⁽²⁾	4	26744	15282
320,5	629	2,5	4,59	S142	180L ⁽²⁾	4	27367	15638

⁽²⁾ With TBS brake motor, please contact our Technical Sales Support

22,00 kW

n2 [rpm]	M2 [Nm]	fs	i	Gear reducer	Size	Motor Pole	Fr2 D [N]	Fr2 C-L [N]
285,8	706	2,5	5,14	S142	180L ⁽²⁾	4	28011	16007
257,4	784	3,8	5,71	S152	180L ⁽²⁾	4	37840	19400
252,6	798	2,5	5,82	S142	180L ⁽²⁾	4	28676	16386
241,3	844	3,2	4,06	S152	200LB ⁽²⁾	6	38438	19400
238,0	856	1,7	4,12	S142	200LB ⁽²⁾	6	28917	16524
236,6	852	2,5	6,21	S142	180L ⁽²⁾	4	29014	16579
225,4	895	3,4	6,52	S152	180L ⁽²⁾	4	39159	19400
216,2	942	3,2	4,53	S152	200LB ⁽²⁾	6	39526	19400
213,7	953	1,7	4,59	S142	200LB ⁽²⁾	6	29440	16823
201,9	999	3,3	7,28	S152	180L ⁽²⁾	4	40000	19400
200,9	1004	1,9	7,32	S142	180L ⁽²⁾	4	29801	17029
190,5	1069	1,7	5,14	S142	200LB ⁽²⁾	6	29952	17116
188,3	1082	2,8	5,20	S152	200LB ⁽²⁾	6	40000	19400
179,1	1126	1,9	8,21	S142	180L ⁽²⁾	4	30294	17311
175,9	1147	3,1	8,36	S152	180L ⁽²⁾	4	40000	19400
173,3	1164	1,3	8,48	S122	180L ⁽²⁾	4	20457	5845
171,6	1187	2,6	5,71	S152	200LB ⁽²⁾	6	40000	19400
168,4	1210	1,7	5,82	S142	200LB ⁽²⁾	6	30440	17394
160,3	1259	3,0	9,17	S152	180L ⁽²⁾	4	40000	19400
158,3	1274	1,9	9,29	S142	180L ⁽²⁾	4	30756	17575
158,1	1276	1,3	9,30	S122	180L ⁽²⁾	4	20797	5942
157,7	1291	1,7	6,21	S142	200LB ⁽²⁾	6	30668	17524
150,2	1356	2,4	6,52	S152	200LB ⁽²⁾	6	40000	19400
148,3	1360	1,9	9,91	S142	180L ⁽²⁾	4	30967	17696
143,6	1405	1,2	10,24	S122	180L ⁽²⁾	4	21137	6039
141,1	1430	2,9	10,42	S152	180L ⁽²⁾	4	40000	19400
134,6	1513	2,3	7,28	S152	200LB ⁽²⁾	6	40000	19400
133,9	1521	1,3	7,32	S142	200LB ⁽²⁾	6	31124	17785
128,9	1565	1,8	11,41	S142	180L ⁽²⁾	4	31327	17901
128,8	1566	1,2	11,42	S122	180L ⁽²⁾	4	21493	6141
119,4	1706	1,3	8,21	S142	200LB ⁽²⁾	6	31329	17902
117,9	1710	1,9	12,46	S152	180L ⁽²⁾	4	40000	19400
117,3	1737	2,1	8,36	S152	200LB ⁽²⁾	6	40000	19400
116,4	1732	1,3	12,63	S122	180L ⁽²⁾	4	21791	6226
114,7	1758	1,5	12,81	S142	180L ⁽²⁾	4	31514	18008
106,8	1907	2,1	9,17	S152	200LB ⁽²⁾	6	40000	19400
106,2	1899	1,3	13,84	S122	180L ⁽²⁾	4	22032	6295
105,7	1909	1,9	13,91	S152	180L ⁽²⁾	4	40000	19400
105,5	1930	1,3	9,29	S142	200LB ⁽²⁾	6	31423	17956
105,4	1933	0,9	9,30	S122	200LB ⁽²⁾	6	21978	6279
103,0	1958	1,2	14,27	S142	180L ⁽²⁾	4	31579	18045
98,9	2061	1,3	9,91	S142	200LB ⁽²⁾	6	31412	17950

(2) With TBS brake motor, please contact our Technical Sales Support

22,00 kW

n2 [rpm]	M2 [Nm]	fs	i	Gear reducer	Motor Size	Pole	Fr2 D [N]	Fr2 C-L [N]
94,1	2166	2,0	10,42	S152	200LB ⁽²⁾	6	40000	19400
92,1	2191	1,9	15,97	S152	180L ⁽²⁾	4	40000	19400
91,8	2196	1,2	16,01	S142	180L ⁽²⁾	4	31516	18009
86,5	2332	1,1	16,99	S122	180L ⁽²⁾	4	22441	6412
85,9	2371	1,2	11,41	S142	200LB ⁽²⁾	6	31223	17842
83,9	2405	1,9	17,53	S152	180L ⁽²⁾	4	40000	19400
81,2	2485	1,2	18,11	S142	180L ⁽²⁾	4	31271	17869
78,6	2591	1,3	12,46	S152	200LB ⁽²⁾	6	40000	19400
76,5	2663	1,0	12,81	S142	200LB ⁽²⁾	6	30870	17640
76,0	2653	1,2	19,33	S142	180L ⁽²⁾	4	31056	17746
73,8	2731	1,9	19,91	S152	180L ⁽²⁾	4	40000	19400
70,5	2891	1,3	13,91	S152	200LB ⁽²⁾	6	40000	19400
69,2	2916	1,0	21,25	S122	180L ⁽²⁾	4	22623	6464
66,1	3052	1,1	22,24	S142	180L ⁽²⁾	4	30369	17354
65,7	3069	0,9	22,37	S122	180L ⁽²⁾	4	22616	6462
64,2	3140	1,9	22,88	S152	180L ⁽²⁾	4	40000	19400
63,1	3196	0,9	23,29	S122	180L ⁽²⁾	4	22597	6456
61,4	3319	1,3	15,97	S152	200LB ⁽²⁾	6	40000	19400
55,9	3643	1,3	17,53	S152	200LB ⁽²⁾	6	40000	19400
54,2	3719	1,6	27,11	S152	180L ⁽²⁾	4	40000	19400
49,4	4082	1,6	29,75	S152	180L ⁽²⁾	4	40000	19400
49,2	4138	1,3	19,91	S152	200LB ⁽²⁾	6	40000	19400
43,5	4636	1,6	33,79	S152	180L ⁽²⁾	4	40000	19400
42,8	4756	1,3	22,88	S152	200LB ⁽²⁾	6	40000	19400
37,8	5329	1,4	38,84	S152	180L ⁽²⁾	4	40000	19400
36,7	5388	1,2	40,10	S153	180L ⁽²⁾	4	40000	19400
36,2	5634	1,1	27,11	S152	200LB ⁽²⁾	6	40000	19400
32,9	6184	1,1	29,75	S152	200LB ⁽²⁾	6	40000	19400
32,8	6013	1,2	44,76	S153	180L ⁽²⁾	4	40000	19400
29,0	7024	1,1	33,79	S152	200LB ⁽²⁾	6	40000	19400
28,6	6903	1,1	51,38	S153	180L ⁽²⁾	4	40000	19400
26,1	7577	1,1	56,39	S153	180L ⁽²⁾	4	40000	19400
25,2	8074	1,0	38,84	S152	200LB ⁽²⁾	6	40000	19400
22,9	8605	1,0	64,05	S153	180L ⁽²⁾	4	40000	19400

30,00 kW

n2 [rpm]	M2 [Nm]	fs	i	Gear reducer	Motor Size	Pole	Fr2 D [N]	Fr2 C-L [N]
363,2	757	3,4	4,06	S152	200L ⁽²⁾	4	33490	19137
358,2	768	1,8	4,12	S142	200L ⁽²⁾	4	25110	14348
325,4	845	3,4	4,53	S152	200L ⁽²⁾	4	34429	19400
321,6	855	1,8	4,59	S142	200L ⁽²⁾	4	25549	14600

(2) With TBS brake motor, please contact our Technical Sales Support

30,00 kW

n2 [rpm]	M2 [Nm]	fs	i	Gear reducer	Size	Motor Pole	Fr2 D [N]	Fr2 C-L [N]
286,8	959	1,8	5,14	S142	200L ⁽²⁾	4	25976	14843
283,4	970	3,0	5,20	S152	200L ⁽²⁾	4	35610	19400
258,2	1065	2,8	5,71	S152	200L ⁽²⁾	4	36402	19400
253,5	1085	1,8	5,82	S142	200L ⁽²⁾	4	26376	15072
237,4	1159	1,8	6,21	S142	200L ⁽²⁾	4	26560	15177
226,1	1216	2,5	6,52	S152	200L ⁽²⁾	4	37521	19400
202,6	1358	2,4	7,28	S152	200L ⁽²⁾	4	38430	19400
201,6	1365	1,4	7,32	S142	200L ⁽²⁾	4	26916	15381
179,7	1530	1,4	8,21	S142	200L ⁽²⁾	4	27062	15464
176,5	1558	2,3	8,36	S152	200L ⁽²⁾	4	39540	19400
173,9	1582	0,9	8,48	S122	200L ⁽²⁾	4	18846	5385
160,8	1710	2,2	9,17	S152	200L ⁽²⁾	4	40000	19400
158,9	1731	1,4	9,29	S142	200L ⁽²⁾	4	27103	15488
158,6	1734	1,0	9,30	S122	200L ⁽²⁾	4	19034	5438
148,8	1849	1,4	9,91	S142	200L ⁽²⁾	4	27070	15468
141,6	1943	2,2	10,42	S152	200L ⁽²⁾	4	40000	19400
129,3	2127	1,3	11,41	S142	200L ⁽²⁾	4	26847	15341
118,3	2324	1,4	12,46	S152	200L ⁽²⁾	4	40000	19400
116,8	2354	0,9	12,63	S122	200L ⁽²⁾	4	19403	5544
115,1	2389	1,1	12,81	S142	200L ⁽²⁾	4	26486	15135
106,6	2581	0,9	13,84	S122	200L ⁽²⁾	4	19417	5548
106,0	2594	1,4	13,91	S152	200L ⁽²⁾	4	40000	19400
103,4	2661	0,9	14,27	S142	200L ⁽²⁾	4	25983	14847
92,4	2978	1,4	15,97	S152	200L ⁽²⁾	4	40000	19400
84,2	3268	1,4	17,53	S152	200L ⁽²⁾	4	40000	19400
74,1	3712	1,4	19,91	S152	200L ⁽²⁾	4	40000	19400
64,5	4267	1,4	22,88	S152	200L ⁽²⁾	4	40000	19400
54,4	5054	1,2	27,11	S152	200L ⁽²⁾	4	40000	19400
49,6	5547	1,2	29,75	S152	200L ⁽²⁾	4	40000	19400
43,7	6301	1,2	33,79	S152	200L ⁽²⁾	4	40000	19400
38,0	7242	1,1	38,84	S152	200L ⁽²⁾	4	40000	19400

37,00 kW

n2 [rpm]	M2 [Nm]	fs	i	Gear reducer	Size	Motor Pole	Fr2 D [N]	Fr2 C-L [N]
365,6	928	2,8	4,06	S152	225S ⁽²⁾	4	32564	18608
327,6	1035	2,8	4,53	S152	225S ⁽²⁾	4	33402	19087
285,4	1189	2,5	5,20	S152	225S ⁽²⁾	4	34440	19400
260,0	1305	2,3	5,71	S152	225S ⁽²⁾	4	35124	19400
227,7	1490	2,1	6,52	S152	225S ⁽²⁾	4	36070	19400
204,0	1663	2,0	7,28	S152	225S ⁽²⁾	4	36818	19400
177,7	1909	1,8	8,36	S152	225S ⁽²⁾	4	37700	19400

⁽²⁾ With TBS brake motor, please contact our Technical Sales Support

37,00 kW

n2 [rpm]	M2 [Nm]	fs	i	Gear reducer	Size	Motor	Pole	Fr2 D [N]	Fr2 C-L [N]
161,9	2095	1,8	9,17	S152	225S ⁽²⁾		4	38249	19400
142,5	2380	1,8	10,42	S152	225S ⁽²⁾		4	38928	19400
119,2	2847	1,2	12,46	S152	225S ⁽²⁾		4	39707	19400
106,8	3177	1,2	13,91	S152	225S ⁽²⁾		4	40000	19400
93,0	3648	1,2	15,97	S152	225S ⁽²⁾		4	40000	19400
84,7	4004	1,2	17,53	S152	225S ⁽²⁾		4	40000	19400
74,6	4547	1,2	19,91	S152	225S ⁽²⁾		4	40000	19400
64,9	5227	1,2	22,88	S152	225S ⁽²⁾		4	39878	19400
54,8	6192	1,0	27,11	S152	225S ⁽²⁾		4	38885	19400
49,9	6796	1,0	29,75	S152	225S ⁽²⁾		4	38066	19400
43,9	7719	1,0	33,79	S152	225S ⁽²⁾		4	36577	19400

45,00 kW

n2 [rpm]	M2 [Nm]	fs	i	Gear reducer	Size	Motor	Pole	Fr2 D [N]	Fr2 C-L [N]
365,6	1128	2,3	4,06	S152	225M ⁽²⁾		4	31572	18041
327,6	1259	2,3	4,53	S152	225M ⁽²⁾		4	32295	18454
285,4	1446	2,0	5,20	S152	225M ⁽²⁾		4	33169	18953
260,0	1587	1,9	5,71	S152	225M ⁽²⁾		4	33729	19274
227,7	1812	1,7	6,52	S152	225M ⁽²⁾		4	34477	19400
204,0	2023	1,6	7,28	S152	225M ⁽²⁾		4	35040	19400
177,7	2322	1,5	8,36	S152	225M ⁽²⁾		4	35658	19400
161,9	2548	1,5	9,17	S152	225M ⁽²⁾		4	36009	19400
142,5	2895	1,4	10,42	S152	225M ⁽²⁾		4	36383	19400
119,2	3462	1,0	12,46	S152	225M ⁽²⁾		4	36662	19400
106,8	3864	1,0	13,91	S152	225M ⁽²⁾		4	36660	19400
93,0	4436	1,0	15,97	S152	225M ⁽²⁾		4	36430	19400
84,7	4869	1,0	17,53	S152	225M ⁽²⁾		4	36110	19400
74,6	5530	1,0	19,91	S152	225M ⁽²⁾		4	35423	19400
64,9	6357	1,0	22,88	S152	225M ⁽²⁾		4	34288	19400

⁽²⁾ With TBS brake motor, please contact our Technical Sales Support

IS052

Mn ₂ [Nm]	i	Pn ₁ [kW]	n ₂ [rpm]	Fr1 [N]	Fr2 D [N]	Fr2 C-L [N]
160	8,63	3,54	202,9	759	3125	3125
179	11,14	3,06	157,1	846	3373	3373
188	12,00	2,99	145,8	859	3428	3428
197	13,66	2,76	128,2	901	3570	3570
226	15,27	2,82	114,6	890	3584	3584
226	16,29	2,64	107,5	922	3689	3689
226	18,63	2,31	93,9	983	3916	3916
226	19,73	2,18	88,7	1007	4015	4015
244	21,04	2,22	83,2	1000	4020	4020
244	21,53	2,17	81,3	1010	4062	4062
244	24,07	1,94	72,7	1051	4267	4267
273	25,20	2,06	69,4	1028	4190	4190
273	25,79	2,02	67,9	1037	4234	4234
273	27,81	1,87	62,9	1064	4381	4381
273	30,00	1,73	58,3	1089	4532	4532
282	32,55	1,65	53,8	1104	4644	4644
282	33,00	1,63	53,0	1108	4673	4673
282	34,09	1,58	51,3	1117	4741	4741
310	36,55	1,62	47,9	1110	4725	4725
310	38,75	1,53	45,2	1127	4853	4853
329	39,90	1,57	43,9	1118	4808	4808
329	42,63	1,47	41,1	1137	4956	4956
329	46,00	1,37	38,0	1156	5131	5131
329	47,20	1,33	37,1	1163	5191	5191
329	52,25	1,20	33,5	1186	5433	5433
329	57,86	1,09	30,2	1208	5685	5685
329	59,42	1,06	29,4	1213	5752	5752
329	72,83	0,86	24,0	1249	6000	6000

IS053

Mn ₂ [Nm]	i	Pn ₁ [kW]	n ₂ [rpm]	Fr1 [N]	Fr2 D [N]	Fr2 C-L [N]
329	36,50	1,76	48,0	1091	4613	4613
329	47,14	1,36	37,1	1162	5188	5188
329	57,79	1,11	30,3	1207	5682	5682
329	63,74	1,01	27,4	1226	5931	5931
329	74,20	0,86	23,6	1251	6000	6000
329	78,14	0,82	22,4	1259	6000	6000
329	95,84	0,67	18,3	1286	6000	6000
329	117,48	0,55	14,9	1309	6000	6000
329	137,45	0,47	12,7	1323	6000	6000
329	177,55	0,36	9,9	1342	6000	6000

IS053

Mn ₂ [Nm]	i	Pn ₁ [kW]	n ₂ [rpm]	Fr1 [N]	Fr2 D [N]	Fr2 C-L [N]
329	198,45	0,32	8,8	1348	6000	6000
329	217,64	0,29	8,0	1354	6000	6000
329	256,33	0,25	6,8	1362	6000	6000
329	314,21	0,20	5,6	1370	6000	6000

IS062

Mn ₂ [Nm]	i	Pn ₁ [kW]	n ₂ [rpm]	Fr1 [N]	Fr2 D [N]	Fr2 C-L [N]
310	8,00	7,40	218,8	413	4832	1933
310	8,92	6,64	196,2	516	5081	2032
338	9,55	6,77	183,3	499	5061	2024
338	10,65	6,07	164,4	593	5325	2130
367	11,71	5,98	149,5	605	5385	2154
395	13,06	5,77	134,0	633	5488	2195
395	13,36	5,64	131,0	650	5548	2219
423	15,94	5,07	109,8	727	5853	2341
423	16,16	5,00	108,3	737	5892	2357
423	19,29	4,19	90,7	846	6407	2563
432	19,55	4,22	89,5	841	6388	2555
442	23,18	3,64	75,5	920	6856	2742
442	23,75	3,55	73,7	931	6934	2774
451	25,14	3,43	69,6	948	7059	2824
451	27,66	3,11	63,3	990	7376	2950
470	30,00	2,99	58,3	1007	7536	3014
508	33,93	2,86	51,6	1025	7733	3093
564	36,57	2,94	47,9	1013	7650	3060
564	39,38	2,73	44,4	1041	7927	3171
564	43,64	2,47	40,1	1077	8324	3329
564	46,10	2,34	38,0	1095	8541	3416
564	48,30	2,23	36,2	1109	8729	3492
564	53,53	2,01	32,7	1138	9154	3661
564	55,00	1,96	31,8	1146	9268	3707
564	67,47	1,60	25,9	1194	10000	4000

IS063

Mn ₂ [Nm]	i	Pn ₁ [kW]	n ₂ [rpm]	Fr1 [N]	Fr2 D [N]	Fr2 C-L [N]
564	33,57	3,28	52,1	978	7337	2935
564	37,77	2,91	46,3	1026	7770	3108
564	40,05	2,74	43,7	1047	7992	3197
564	49,13	2,24	35,6	1114	8799	3519

IS063

Mn ₂ [Nm]	i	Pn ₁ [kW]	n ₂ [rpm]	Fr1 [N]	Fr2 D [N]	Fr2 C-L [N]
564	55,29	1,99	31,6	1147	9290	3716
564	58,72	1,87	29,8	1162	9548	3819
564	65,85	1,67	26,6	1189	10000	4000
564	68,25	1,61	25,6	1197	10000	4000
564	73,63	1,49	23,8	1212	10000	4000
564	81,43	1,35	21,5	1231	10000	4000
564	99,89	1,10	17,5	1264	10000	4000
564	126,43	0,87	13,8	1294	10000	4000
564	150,85	0,73	11,6	1313	10000	4000
564	182,53	0,60	9,6	1330	10000	4000
564	185,05	0,59	9,5	1331	10000	4000
564	217,79	0,50	8,0	1342	10000	4000
564	267,16	0,41	6,5	1355	10000	4000

IS082

Mn ₂ [Nm]	i	Pn ₁ [kW]	n ₂ [rpm]	Fr1 [N]	Fr2 D [N]	Fr2 C-L [N]
517	7,34	13,45	238,4	1365	11156	3188
564	8,06	13,35	217,1	1376	11407	3259
611	9,94	11,73	176,0	1572	12203	3487
658	11,61	10,82	150,8	1681	12792	3655
705	12,75	10,55	137,2	1714	13109	3745
714	14,04	9,71	124,6	1816	13578	3879
724	15,43	8,95	113,4	1907	14049	4014
724	15,73	8,79	111,3	1927	14153	4044
724	17,29	7,99	101,2	2023	14680	4194
724	19,03	7,26	92,0	2111	15226	4350
724	20,14	6,86	86,9	2159	15559	4445
752	22,13	6,49	79,1	2204	16032	4580
752	24,00	5,98	72,9	2265	16535	4724
752	26,05	5,51	67,2	2322	17056	4873
846	27,29	5,92	64,1	2273	17049	4871
846	28,67	5,63	61,0	2308	17375	4964
846	29,60	5,46	59,1	2329	17588	5025
940	31,78	5,65	55,1	2306	17762	5075
940	34,91	5,14	50,1	2367	18000	5263
940	35,50	5,05	49,3	2377	18000	5297
940	40,05	4,48	43,7	2447	18000	5548
940	43,05	4,17	40,6	2484	18000	5703
940	50,25	3,57	34,8	2556	18000	6047
940	54,27	3,31	32,2	2588	18000	6226
940	61,98	2,90	28,2	2638	18000	6544

IS083

Mn ₂ [Nm]	i	Pn ₁ [kW]	n ₂ [rpm]	Fr1 [N]	Fr2 D [N]	Fr2 C-L [N]
940	67,52	2,71	25,9	2667	18000	6757
940	74,18	2,47	23,6	2695	18000	6998
940	81,71	2,24	21,4	2722	18000	7200
940	91,49	2,00	19,1	2750	18000	7200
940	100,62	1,82	17,4	2772	18000	7200
940	117,17	1,56	14,9	2802	18000	7200
940	128,73	1,42	13,6	2819	18000	7200
940	136,34	1,34	12,8	2828	18000	7200
940	158,76	1,15	11,0	2851	18000	7200
940	184,88	0,99	9,5	2870	18000	7200
940	203,11	0,90	8,6	2881	18000	7200
940	205,34	0,89	8,5	2882	18000	7200
940	226,04	0,81	7,7	2891	18000	7200
940	250,50	0,73	7,0	2901	18000	7200
940	266,13	0,69	6,6	2906	18000	7200
940	292,36	0,63	6,0	2913	18000	7200
940	315,73	0,58	5,5	2919	18000	7200
940	360,58	0,51	4,8	2927	18000	7200

IS102

Mn ₂ [Nm]	i	Pn ₁ [kW]	n ₂ [rpm]	Fr1 [N]	Fr2 D [N]	Fr2 C-L [N]
799	8,06	18,92	217,1	788	14063	4018
846	8,85	18,25	197,8	865	14442	4126
893	10,88	15,66	160,8	1166	15499	4428
940	12,75	14,07	137,2	1351	16332	4666
1128	13,99	15,39	125,1	1198	16427	4694
1175	15,43	14,54	113,4	1297	16941	4840
1222	17,21	13,55	101,7	1412	17554	5015
1316	19,00	13,22	92,1	1450	17997	5142
1316	20,83	12,06	84,0	1585	18656	5330
1316	22,13	11,35	79,1	1668	19100	5457
1410	24,28	11,09	72,1	1699	19556	5588
1410	26,33	10,22	66,5	1800	20188	5768
1410	29,87	9,01	58,6	1940	21200	6057
1410	32,40	8,31	54,0	2022	21877	6250
1316	34,91	7,20	50,1	2152	22000	6502
1410	38,30	7,03	45,7	2171	22000	6665
1316	42,53	5,91	41,1	2301	22000	7005
1222	44,00	5,30	39,8	2372	22000	7165
1504	47,13	6,09	37,1	2280	22000	7141
1316	50,25	5,00	34,8	2407	22000	7457

IS102

Mn ₂ [Nm]	i	Pn ₁ [kW]	n ₂ [rpm]	Fr1 [N]	Fr2 D [N]	Fr2 C-L [N]
1222	55,14	4,23	31,7	2497	22000	7789
1504	59,40	4,83	29,5	2426	22000	7796
1504	67,84	4,23	25,8	2496	22000	8196

IS103

Mn ₂ [Nm]	i	Pn ₁ [kW]	n ₂ [rpm]	Fr1 [N]	Fr2 D [N]	Fr2 C-L [N]
1504	74,18	3,95	23,6	2539	22000	8474
1504	81,39	3,60	21,5	2578	22000	8773
1504	89,77	3,27	19,5	2617	22000	9000
1504	100,15	2,93	17,5	2655	22000	9000
1504	110,55	2,65	15,8	2687	22000	9000
1504	121,29	2,42	14,4	2713	22000	9000
1504	128,73	2,28	13,6	2729	22000	9000
1504	141,24	2,08	12,4	2752	22000	9000
1504	173,78	1,69	10,1	2797	22000	9000
1504	188,51	1,56	9,3	2812	22000	9000
1504	203,11	1,44	8,6	2824	22000	9000
1504	222,85	1,32	7,8	2839	22000	9000
1504	224,76	1,30	7,8	2840	22000	9000
1504	274,20	1,07	6,4	2867	22000	9000
1504	280,89	1,04	6,2	2870	22000	9000
1504	292,36	1,00	6,0	2875	22000	9000
1504	320,79	0,91	5,5	2885	22000	9000
1504	345,60	0,85	5,1	2892	22000	9000
1504	394,69	0,74	4,4	2904	22000	9000

IS122

Mn ₂ [Nm]	i	Pn ₁ [kW]	n ₂ [rpm]	Fr1 [N]	Fr2 D [N]	Fr2 C-L [N]
1410	8,48	31,73	206,3	3012	18134	5181
1598	9,30	32,81	188,2	2979	18143	5184
1598	10,24	29,79	170,9	3070	18925	5407
1786	11,42	29,86	153,3	3068	19127	5465
2068	12,63	31,26	138,6	3026	18934	5410
2256	13,84	31,12	126,5	3030	19045	5441
2444	16,99	27,45	103,0	3140	20267	5791
2632	21,25	23,64	82,3	3255	21815	6233
2632	22,37	22,46	78,2	3290	22357	6388
2726	23,29	22,34	75,1	3294	22436	6410
2820	26,15	20,58	66,9	3347	23357	6674

IS122

Mn ₂ [Nm]	i	Pn ₁ [kW]	n ₂ [rpm]	Fr1 [N]	Fr2 D [N]	Fr2 C-L [N]
2820	28,60	18,82	61,2	3400	24377	6965
2820	30,51	17,64	57,4	3435	25134	7181
2820	32,76	16,43	53,4	3471	25982	7423
2820	33,44	16,09	52,3	3482	26235	7496
2820	35,20	15,29	49,7	3506	26863	7675
2820	41,07	13,11	42,6	3571	28822	8235
2820	43,60	12,35	40,1	3594	29610	8460
2256	44,63	9,65	39,2	3675	30000	9160
2256	49,04	8,78	35,7	3702	30000	9526
2444	53,75	8,68	32,6	3705	30000	9690
2820	66,00	8,16	26,5	3720	30000	10148

IS123

Mn ₂ [Nm]	i	Pn ₁ [kW]	n ₂ [rpm]	Fr1 [N]	Fr2 D [N]	Fr2 C-L [N]
2538	64,84	7,63	27,0	3741	30000	10376
2538	71,07	6,96	24,6	3761	30000	10780
2820	78,46	7,01	22,3	3759	30000	10923
2820	87,27	6,30	20,1	3780	30000	11200
2820	105,91	5,19	16,5	3813	30000	11200
2820	112,52	4,89	15,6	3822	30000	11200
2820	123,33	4,46	14,2	3834	30000	11200
2820	130,04	4,23	13,5	3841	30000	11200
2820	133,78	4,11	13,1	3845	30000	11200
2820	151,43	3,63	11,6	3859	30000	11200
2820	177,53	3,10	9,9	3874	30000	11200
2820	194,59	2,83	9,0	3882	30000	11200
2820	215,60	2,55	8,1	3890	30000	11200
2820	238,93	2,30	7,3	3898	30000	11200

IS142

Mn ₂ [Nm]	i	Pn ₁ [kW]	n ₂ [rpm]	Fr1 [N]	Fr2 D [N]	Fr2 C-L [N]
1306	4,12	60,53	425,0	2548	19159	10948
1455	4,59	60,57	381,6	2546	19045	10883
1633	5,14	60,61	340,2	2545	18820	10754
1846	5,82	60,56	300,7	2547	18458	10548
1973	6,21	60,62	281,7	2545	18177	10387
1801	7,32	46,97	239,2	3073	21411	12235
2020	8,21	46,97	213,2	3073	21057	12033
2286	9,29	46,99	188,5	3073	20496	11712

IS142

Mn ₂ [Nm]	i	Pn ₁ [kW]	n ₂ [rpm]	Fr1 [N]	Fr2 D [N]	Fr2 C-L [N]
2441	9,91	47,00	176,5	3072	20113	11493
2647	11,41	44,30	153,4	3177	20353	11630
2463	12,81	36,69	136,6	3471	23418	13382
2294	14,27	30,68	122,6	3704	26304	15031
2493	16,01	29,73	109,3	3741	26448	15113
2820	18,11	29,73	96,6	3741	25783	14733
3011	19,33	29,73	90,5	3741	25321	14469
3116	22,24	26,74	78,7	3857	26820	15326
2722	25,26	20,57	69,3	4096	32131	18360
3053	28,33	20,57	61,8	4096	31591	18052
3454	32,05	20,57	54,6	4096	30742	17567
3688	34,22	20,57	51,1	4096	30165	17237
4165	39,38	20,19	44,4	4111	29206	16689

IS143

Mn ₂ [Nm]	i	Pn ₁ [kW]	n ₂ [rpm]	Fr1 [N]	Fr2 D [N]	Fr2 C-L [N]
3772	45,77	16,07	38,2	4200	35000	18500
4202	50,97	16,07	34,3	4200	34436	18500
4450	57,17	15,17	30,6	4200	35000	18500
4488	64,68	13,53	27,1	4200	35000	18500
4584	69,06	12,94	25,3	4200	35000	18500
3979	79,45	9,76	22,0	4200	35000	18500
4174	98,81	8,23	17,7	4200	35000	18500
4450	110,05	7,88	15,9	4200	35000	18500
4469	123,44	7,06	14,2	4200	35000	18500
4550	139,64	6,35	12,5	4200	35000	18500
4499	149,10	5,88	11,7	4200	35000	18500
3573	157,49	4,42	11,1	4200	35000	18500
4389	171,55	4,99	10,2	4200	35000	18500
3980	175,41	4,42	10,0	4200	35000	18500
4464	196,74	4,42	8,9	4200	35000	18500
4432	222,57	3,88	7,9	4200	35000	18500
4589	237,63	3,76	7,4	4200	35000	18500
4504	273,41	3,21	6,4	4200	35000	18500

IS152

Mn ₂ [Nm]	i	Pn ₁ [kW]	n ₂ [rpm]	Fr1 [N]	Fr2 D [N]	Fr2 C-L [N]
2419	4,06	113,68	430,9	2971	23230	13274
2699	4,53	113,65	386,1	2972	23144	13225

IS152

Mn ₂ [Nm]	i	Pn ₁ [kW]	n ₂ [rpm]	Fr1 [N]	Fr2 D [N]	Fr2 C-L [N]
2739	5,20	100,47	336,3	3282	24645	14083
2765	5,71	92,42	306,4	3471	25706	14689
2891	6,52	84,58	268,3	3656	26853	15345
3063	7,28	80,32	240,4	3756	27516	15724
3319	8,36	75,81	209,4	3862	28240	16137
3526	9,17	73,37	190,8	3919	28610	16349
3931	10,42	72,02	168,0	3951	28583	16333
3107	12,46	47,59	140,4	4525	35582	19400
3467	13,91	47,57	125,8	4526	35686	19400
3980	15,97	47,58	109,6	4526	35607	19400
4369	17,53	47,59	99,8	4525	35408	19400
4963	19,91	47,59	87,9	4525	34919	19400
5706	22,88	47,60	76,5	4525	34041	19400
5724	27,11	40,31	64,6	4697	37532	19400
6284	29,75	40,32	58,8	4696	36818	19400
7137	33,79	40,32	51,8	4696	35512	19400
7228	38,84	35,52	45,1	4809	38394	19400

IS153

Mn ₂ [Nm]	i	Pn ₁ [kW]	n ₂ [rpm]	Fr1 [N]	Fr2 D [N]	Fr2 C-L [N]
5905	40,10	28,70	43,6	4984	40000	19400
6589	44,76	28,70	39,1	4984	40000	19400
7393	51,38	28,05	34,1	4999	40000	19400
7759	56,39	26,82	31,0	5027	40000	19400
8268	64,05	25,16	27,3	5065	40000	19400
7313	73,63	19,36	23,8	5199	40000	19400
6679	87,16	14,94	20,1	5200	40000	19400
7455	97,27	14,94	18,0	5200	40000	19400
8558	111,67	14,94	15,7	5200	40000	19400
8964	122,57	14,26	14,3	5200	40000	19400
8593	139,21	12,03	12,6	5200	40000	19400
6701	154,02	8,48	11,4	5200	40000	19400
7599	160,02	9,26	10,9	5200	40000	19400
7693	176,81	8,48	9,9	5200	40000	19400
8443	194,06	8,48	9,0	5200	40000	19400
8792	220,42	7,78	7,9	5200	40000	19400
7782	253,36	5,99	6,9	5200	40000	19400

IS052

Mn ₂ [Nm]	i	Pn ₁ [kW]	n ₂ [rpm]	Fr1 [N]	Fr2 D [N]	Fr2 C-L [N]
170	8,63	3,01	162,3	718	3375	3375
190	11,14	2,60	125,7	810	3644	3644
200	12,00	2,55	116,7	824	3703	3703
210	13,66	2,35	102,5	869	3857	3857
240	15,27	2,40	91,7	857	3874	3874
240	16,29	2,25	86,0	891	3987	3987
240	18,63	1,97	75,1	956	4231	4231
240	19,73	1,86	71,0	981	4338	4338
260	21,04	1,89	66,5	974	4345	4345
260	21,53	1,84	65,0	984	4390	4390
260	24,07	1,65	58,2	1029	4611	4611
290	25,20	1,76	55,6	1004	4530	4530
290	25,79	1,72	54,3	1013	4578	4578
290	27,81	1,59	50,3	1042	4736	4736
290	30,00	1,48	46,7	1069	4898	4898
300	32,55	1,41	43,0	1084	5020	5020
300	33,00	1,39	42,4	1089	5051	5051
300	34,09	1,34	41,1	1099	5124	5124
330	36,55	1,38	38,3	1091	5109	5109
330	38,75	1,30	36,1	1109	5246	5246
350	39,90	1,34	35,1	1100	5200	5200
350	42,63	1,25	32,8	1119	5359	5359
350	46,00	1,16	30,4	1140	5547	5547
350	47,20	1,13	29,7	1147	5612	5612
350	52,25	1,02	26,8	1172	5873	5873
350	57,86	0,92	24,2	1195	6000	6000
350	59,42	0,90	23,6	1201	6000	6000
350	72,83	0,73	19,2	1238	6000	6000

IS053

Mn ₂ [Nm]	i	Pn ₁ [kW]	n ₂ [rpm]	Fr1 [N]	Fr2 D [N]	Fr2 C-L [N]
350	36,50	1,50	38,4	1071	4990	4990
350	47,14	1,16	29,7	1147	5609	5609
350	57,79	0,94	24,2	1195	6000	6000
350	63,74	0,86	22,0	1214	6000	6000
350	74,20	0,74	18,9	1242	6000	6000
350	78,14	0,70	17,9	1250	6000	6000
350	95,84	0,57	14,6	1279	6000	6000
350	117,48	0,46	11,9	1302	6000	6000
350	137,45	0,40	10,2	1317	6000	6000
350	177,55	0,31	7,9	1338	6000	6000

IS053

Mn ₂ [Nm]	i	Pn ₁ [kW]	n ₂ [rpm]	Fr1 [N]	Fr2 D [N]	Fr2 C-L [N]
350	198,45	0,28	7,0	1345	6000	6000
350	217,64	0,25	6,4	1350	6000	6000
350	256,33	0,21	5,5	1359	6000	6000
350	314,21	0,17	4,5	1367	6000	6000

IS062

Mn ₂ [Nm]	i	Pn ₁ [kW]	n ₂ [rpm]	Fr1 [N]	Fr2 D [N]	Fr2 C-L [N]
330	8,00	6,30	175,0	350	5225	2090
330	8,92	5,65	156,9	459	5494	2197
360	9,55	5,76	146,7	441	5474	2190
360	10,65	5,16	131,5	541	5759	2303
390	11,71	5,09	119,6	554	5825	2330
420	13,06	4,91	107,2	583	5939	2376
420	13,36	4,80	104,8	602	6004	2401
450	15,94	4,31	87,8	684	6334	2533
450	16,16	4,25	86,6	694	6376	2551
450	19,29	3,56	72,6	810	6930	2772
460	19,55	3,59	71,6	805	6911	2764
470	23,18	3,10	60,4	888	7415	2966
470	23,75	3,02	59,0	901	7499	3000
480	25,14	2,92	55,7	919	7635	3054
480	27,66	2,65	50,6	963	7976	3190
500	30,00	2,55	46,7	981	8149	3260
540	33,93	2,43	41,3	1000	8364	3346
600	36,57	2,51	38,3	988	8280	3312
600	39,38	2,33	35,6	1018	8578	3431
600	43,64	2,10	32,1	1056	9005	3602
600	46,10	1,99	30,4	1075	9239	3695
600	48,30	1,90	29,0	1090	9441	3776
600	53,53	1,71	26,1	1121	9898	3959
600	55,00	1,67	25,4	1129	10000	4000
600	67,47	1,36	20,8	1181	10000	4000

IS063

Mn ₂ [Nm]	i	Pn ₁ [kW]	n ₂ [rpm]	Fr1 [N]	Fr2 D [N]	Fr2 C-L [N]
600	33,57	2,79	41,7	950	7943	3177
600	37,77	2,48	37,1	1001	8409	3364
600	40,05	2,34	35,0	1024	8648	3459
600	49,13	1,90	28,5	1095	9516	3806

IS063

Mn ₂ [Nm]	i	Pn ₁ [kW]	n ₂ [rpm]	Fr1 [N]	Fr2 D [N]	Fr2 C-L [N]
600	55,29	1,69	25,3	1130	10000	4000
600	58,72	1,59	23,8	1147	10000	4000
600	65,85	1,42	21,3	1175	10000	4000
600	68,25	1,37	20,5	1183	10000	4000
600	73,63	1,27	19,0	1200	10000	4000
600	81,43	1,15	17,2	1220	10000	4000
600	99,89	0,94	14,0	1255	10000	4000
600	126,43	0,74	11,1	1287	10000	4000
600	150,85	0,62	9,3	1307	10000	4000
600	182,53	0,51	7,7	1324	10000	4000
600	185,05	0,51	7,6	1326	10000	4000
600	217,79	0,43	6,4	1338	10000	4000
600	267,16	0,35	5,2	1351	10000	4000

IS082

Mn ₂ [Nm]	i	Pn ₁ [kW]	n ₂ [rpm]	Fr1 [N]	Fr2 D [N]	Fr2 C-L [N]
550	7,34	11,44	190,8	1261	12030	3437
600	8,06	11,36	173,6	1273	12302	3515
650	9,94	9,98	140,8	1482	13161	3760
700	11,61	9,21	120,6	1598	13797	3942
750	12,75	8,98	109,8	1632	14140	4040
760	14,04	8,26	99,7	1741	14645	4184
770	15,43	7,62	90,7	1838	15153	4329
770	15,73	7,48	89,0	1859	15264	4361
770	17,29	6,80	81,0	1962	15832	4523
770	19,03	6,18	73,6	2055	16420	4691
770	20,14	5,84	69,5	2107	16778	4794
800	22,13	5,52	63,3	2154	17288	4939
800	24,00	5,09	58,3	2219	17830	5094
800	26,05	4,69	53,8	2280	18000	5254
900	27,29	5,04	51,3	2228	18000	5253
900	28,67	4,79	48,8	2264	18000	5354
900	29,60	4,64	47,3	2287	18000	5419
1000	31,78	4,81	44,1	2262	18000	5474
1000	34,91	4,37	40,1	2327	18000	5676
1000	35,50	4,30	39,4	2338	18000	5713
1000	40,05	3,81	35,0	2412	18000	5983
1000	43,05	3,55	32,5	2452	18000	6150
1000	50,25	3,04	27,9	2529	18000	6521
1000	54,27	2,81	25,8	2563	18000	6712
1000	61,98	2,46	22,6	2616	18000	7055

IS083

Mn ₂ [Nm]	i	Pn ₁ [kW]	n ₂ [rpm]	Fr1 [N]	Fr2 D [N]	Fr2 C-L [N]
1000	67,52	2,31	20,7	2646	18000	7200
1000	74,18	2,10	18,9	2677	18000	7200
1000	81,71	1,91	17,1	2705	18000	7200
1000	91,49	1,70	15,3	2735	18000	7200
1000	100,62	1,55	13,9	2758	18000	7200
1000	117,17	1,33	11,9	2791	18000	7200
1000	128,73	1,21	10,9	2808	18000	7200
1000	136,34	1,14	10,3	2818	18000	7200
1000	158,76	0,98	8,8	2842	18000	7200
1000	184,88	0,84	7,6	2863	18000	7200
1000	203,11	0,77	6,9	2874	18000	7200
1000	205,34	0,76	6,8	2875	18000	7200
1000	226,04	0,69	6,2	2885	18000	7200
1000	250,50	0,62	5,6	2895	18000	7200
1000	266,13	0,59	5,3	2901	18000	7200
1000	292,36	0,53	4,8	2908	18000	7200
1000	315,73	0,49	4,4	2914	18000	7200
1000	360,58	0,43	3,9	2923	18000	7200

IS102

Mn ₂ [Nm]	i	Pn ₁ [kW]	n ₂ [rpm]	Fr1 [N]	Fr2 D [N]	Fr2 C-L [N]
850	8,06	16,10	173,6	647	15163	4332
900	8,85	15,54	158,3	729	15574	4450
950	10,88	13,33	128,6	1050	16712	4775
1000	12,75	11,98	109,8	1247	17610	5032
1200	13,99	13,10	100,1	1084	17719	5063
1250	15,43	12,37	90,7	1189	18274	5221
1300	17,21	11,53	81,3	1311	18935	5410
1400	19,00	11,25	73,7	1352	19415	5547
1400	20,83	10,26	67,2	1496	20125	5750
1400	22,13	9,66	63,3	1583	20603	5886
1500	24,28	9,44	57,7	1616	21097	6028
1500	26,33	8,70	53,2	1724	21777	6222
1500	29,87	7,67	46,9	1873	22000	6533
1500	32,40	7,07	43,2	1961	22000	6741
1400	34,91	6,12	40,1	2098	22000	7011
1500	38,30	5,98	36,5	2119	22000	7187
1400	42,53	5,03	32,9	2258	22000	7553
1300	44,00	4,51	31,8	2333	22000	7724
1600	47,13	5,18	29,7	2235	22000	7701
1400	50,25	4,25	27,9	2370	22000	8039

IS102

Mn_2 [Nm]	i	Pn_1 [kW]	n_2 [rpm]	Fr1 [N]	Fr2 D [N]	Fr2 C-L [N]
1300	55,14	3,60	25,4	2465	22000	8396
1600	59,40	4,11	23,6	2391	22000	8406
1600	67,84	3,60	20,6	2465	22000	8836

IS103

Mn_2 [Nm]	i	Pn_1 [kW]	n_2 [rpm]	Fr1 [N]	Fr2 D [N]	Fr2 C-L [N]
1600	74,18	3,36	18,9	2510	22000	9000
1600	81,39	3,07	17,2	2552	22000	9000
1600	89,77	2,78	15,6	2593	22000	9000
1600	100,15	2,49	14,0	2634	22000	9000
1600	110,55	2,26	12,7	2667	22000	9000
1600	121,29	2,06	11,5	2696	22000	9000
1600	128,73	1,94	10,9	2713	22000	9000
1600	141,24	1,77	9,9	2737	22000	9000
1600	173,78	1,44	8,1	2784	22000	9000
1600	188,51	1,32	7,4	2800	22000	9000
1600	203,11	1,23	6,9	2814	22000	9000
1600	222,85	1,12	6,3	2829	22000	9000
1600	224,76	1,11	6,2	2831	22000	9000
1600	274,20	0,91	5,1	2859	22000	9000
1600	280,89	0,89	5,0	2862	22000	9000
1600	292,36	0,85	4,8	2867	22000	9000
1600	320,79	0,78	4,4	2878	22000	9000
1600	345,60	0,72	4,0	2886	22000	9000
1600	394,69	0,63	3,5	2899	22000	9000

IS122

Mn_2 [Nm]	i	Pn_1 [kW]	n_2 [rpm]	Fr1 [N]	Fr2 D [N]	Fr2 C-L [N]
1500	8,48	27,00	165,1	2951	19587	5596
1700	9,30	27,92	150,6	2916	19606	5602
1700	10,24	25,36	136,7	3013	20448	5842
1900	11,42	25,41	122,6	3010	20674	5907
2200	12,63	26,61	110,9	2966	20480	5851
2400	13,84	26,48	101,2	2970	20608	5888
2600	16,99	23,36	82,4	3087	21932	6266
2800	21,25	20,12	65,9	3209	23608	6745
2800	22,37	19,12	62,6	3247	24191	6912
2900	23,29	19,01	60,1	3251	24280	6937
3000	26,15	17,52	53,5	3307	25277	7222

IS122

Mn ₂ [Nm]	i	Pn ₁ [kW]	n ₂ [rpm]	Fr1 [N]	Fr2 D [N]	Fr2 C-L [N]
3000	28,60	16,02	49,0	3364	26374	7535
3000	30,51	15,01	45,9	3401	27189	7768
3000	32,76	13,99	42,7	3440	28102	8029
3000	33,44	13,70	41,9	3451	28374	8107
3000	35,20	13,01	39,8	3476	29050	8300
3000	41,07	11,16	34,1	3546	30000	8903
3000	43,60	10,51	32,1	3571	30000	9145
2400	44,63	8,21	31,4	3657	30000	9890
2400	49,04	7,47	28,6	3685	30000	10285
2600	53,75	7,39	26,1	3688	30000	10464
3000	66,00	6,94	21,2	3705	30000	10962

IS123

Mn ₂ [Nm]	i	Pn ₁ [kW]	n ₂ [rpm]	Fr1 [N]	Fr2 D [N]	Fr2 C-L [N]
2700	64,84	6,49	21,6	3727	30000	11200
2700	71,07	5,92	19,7	3748	30000	11200
3000	78,46	5,96	17,8	3746	30000	11200
3000	87,27	5,36	16,0	3768	30000	11200
3000	105,91	4,42	13,2	3803	30000	11200
3000	112,52	4,16	12,4	3813	30000	11200
3000	123,33	3,79	11,3	3826	30000	11200
3000	130,04	3,60	10,8	3833	30000	11200
3000	133,78	3,50	10,5	3837	30000	11200
3000	151,43	3,09	9,2	3852	30000	11200
3000	177,53	2,64	7,9	3869	30000	11200
3000	194,59	2,40	7,2	3877	30000	11200
3000	215,60	2,17	6,5	3886	30000	11200
3000	238,93	1,96	5,9	3894	30000	11200

IS142

Mn ₂ [Nm]	i	Pn ₁ [kW]	n ₂ [rpm]	Fr1 [N]	Fr2 D [N]	Fr2 C-L [N]
1389	4,12	51,51	340,0	2398	20752	11858
1548	4,59	51,55	305,3	2397	20645	11797
1737	5,14	51,58	272,2	2395	20421	11669
1964	5,82	51,54	240,6	2397	20052	11458
2099	6,21	51,59	225,3	2395	19762	11293
1915	7,32	39,97	191,3	2957	23226	13272
2149	8,21	39,98	170,6	2957	22867	13067
2432	9,29	39,99	150,8	2956	22289	12736

IS142

Mn_2 [Nm]	i	Pn_1 [kW]	n2 [rpm]	Fr1 [N]	Fr2 D [N]	Fr2 C-L [N]
2597	9,91	40,00	141,2	2956	21893	12510
2816	11,41	37,70	122,7	3067	22171	12669
2620	12,81	31,23	109,3	3381	25452	14544
2440	14,27	26,11	98,1	3628	28542	16309
2652	16,01	25,30	87,5	3668	28716	16409
3000	18,11	25,30	77,3	3668	28033	16019
3204	19,33	25,30	72,4	3667	27555	15746
3315	22,24	22,76	62,9	3791	29179	16674
2896	25,26	17,51	55,4	4045	34856	18500
3248	28,33	17,50	49,4	4045	34308	18500
3674	32,05	17,50	43,7	4045	33434	18500
3923	34,22	17,50	40,9	4045	32836	18500
4431	39,38	17,18	35,6	4061	31852	18201

IS143

Mn_2 [Nm]	i	Pn_1 [kW]	n2 [rpm]	Fr1 [N]	Fr2 D [N]	Fr2 C-L [N]
4013	45,77	13,67	30,6	4200	35000	18500
4470	50,97	13,68	27,5	4200	35000	18500
4735	57,17	12,91	24,5	4200	35000	18500
4774	64,68	11,51	21,6	4200	35000	18500
4876	69,06	11,01	20,3	4200	35000	18500
4233	79,45	8,31	17,6	4200	35000	18500
4440	98,81	7,01	14,2	4200	35000	18500
4734	110,05	6,71	12,7	4200	35000	18500
4754	123,44	6,01	11,3	4200	35000	18500
4841	139,64	5,41	10,0	4200	35000	18500
4786	149,10	5,01	9,4	4200	35000	18500
3801	157,49	3,76	8,9	4200	35000	18500
4669	171,55	4,24	8,2	4200	35000	18500
4234	175,41	3,76	8,0	4200	35000	18500
4749	196,74	3,76	7,1	4200	35000	18500
4715	222,57	3,30	6,3	4200	35000	18500
4882	237,63	3,20	5,9	4200	35000	18500
4792	273,41	2,73	5,1	4200	35000	18500

IS152

Mn_2 [Nm]	i	Pn_1 [kW]	n2 [rpm]	Fr1 [N]	Fr2 D [N]	Fr2 C-L [N]
2573	4,06	96,75	344,7	2801	25156	14375
2871	4,53	96,72	308,9	2802	25081	14332

IS152

Mn ₂ [Nm]	i	Pn ₁ [kW]	n ₂ [rpm]	Fr1 [N]	Fr2 D [N]	Fr2 C-L [N]
2914	5,20	85,51	269,0	3131	26699	15256
2942	5,71	78,66	245,1	3333	27843	15910
3075	6,52	71,99	214,6	3529	29085	16620
3259	7,28	68,36	192,3	3635	29810	17034
3531	8,36	64,52	167,5	3748	30605	17488
3751	9,17	62,44	152,6	3809	31016	17723
4182	10,42	61,29	134,4	3843	31012	17721
3306	12,46	40,50	112,3	4454	38494	19400
3688	13,91	40,49	100,7	4454	38629	19400
4234	15,97	40,49	87,7	4454	38576	19400
4648	17,53	40,50	79,9	4454	38385	19400
5280	19,91	40,50	70,3	4454	37896	19400
6070	22,88	40,51	61,2	4454	36997	19400
6089	27,11	34,30	51,6	4636	40000	19400
6685	29,75	34,31	47,1	4636	40000	19400
7592	33,79	34,31	41,4	4636	38670	19400
7689	38,84	30,23	36,0	4756	40000	19400

IS153

Mn ₂ [Nm]	i	Pn ₁ [kW]	n ₂ [rpm]	Fr1 [N]	Fr2 D [N]	Fr2 C-L [N]
6281	40,10	24,43	34,9	4941	40000	19400
7010	44,76	24,43	31,3	4941	40000	19400
7865	51,38	23,87	27,2	4957	40000	19400
8254	56,39	22,83	24,8	4987	40000	19400
8795	64,05	21,41	21,9	5028	40000	19400
7779	73,63	16,48	19,0	5170	40000	19400
7105	87,16	12,71	16,1	5200	40000	19400
7931	97,27	12,71	14,4	5200	40000	19400
9104	111,67	12,71	12,5	5200	40000	19400
9536	122,57	12,13	11,4	5200	40000	19400
9142	139,21	10,24	10,1	5200	40000	19400
7129	154,02	7,22	9,1	5200	40000	19400
8084	160,02	7,88	8,8	5200	40000	19400
8184	176,81	7,22	7,9	5200	40000	19400
8982	194,06	7,22	7,2	5200	40000	19400
9353	220,42	6,62	6,3	5200	40000	19400
8279	253,36	5,10	5,5	5200	40000	19400

IS052

Mn ₂ [Nm]	i	Pn ₁ [kW]	n ₂ [rpm]	Fr1 [N]	Fr2 D [N]	Fr2 C-L [N]
174	8,63	2,51	132,2	700	3657	3657
195	11,14	2,17	102,3	795	3949	3949
205	12,00	2,12	95,0	809	4016	4016
215	13,66	1,96	83,5	855	4183	4183
246	15,27	2,00	74,6	843	4209	4209
246	16,29	1,88	70,0	878	4330	4330
246	18,63	1,64	61,2	945	4591	4591
246	19,73	1,55	57,8	971	4706	4706
267	21,04	1,58	54,2	964	4718	4718
267	21,53	1,54	53,0	974	4766	4766
267	24,07	1,38	47,4	1019	5003	5003
297	25,20	1,47	45,2	994	4924	4924
297	25,79	1,43	44,2	1003	4975	4975
297	27,81	1,33	41,0	1033	5144	5144
297	30,00	1,23	38,0	1060	5318	5318
308	32,55	1,17	35,0	1076	5451	5451
308	33,00	1,16	34,5	1081	5484	5484
308	34,09	1,12	33,4	1091	5562	5562
338	36,55	1,15	31,2	1083	5554	5554
338	38,75	1,09	29,4	1101	5701	5701
359	39,90	1,12	28,6	1092	5656	5656
359	42,63	1,05	26,7	1112	5827	5827
359	46,00	0,97	24,8	1134	6000	6000
359	47,20	0,95	24,1	1141	6000	6000
359	52,25	0,85	21,8	1166	6000	6000
359	57,86	0,77	19,7	1190	6000	6000
359	59,42	0,75	19,2	1195	6000	6000
359	72,83	0,61	15,7	1234	6000	6000

IS053

Mn ₂ [Nm]	i	Pn ₁ [kW]	n ₂ [rpm]	Fr1 [N]	Fr2 D [N]	Fr2 C-L [N]
359	36,50	1,25	31,2	1063	5432	5432
359	47,14	0,97	24,2	1140	6000	6000
359	57,79	0,79	19,7	1189	6000	6000
359	63,74	0,71	17,9	1210	6000	6000
359	74,20	0,61	15,4	1237	6000	6000
359	78,14	0,58	14,6	1246	6000	6000
359	95,84	0,48	11,9	1276	6000	6000
359	117,48	0,39	9,7	1300	6000	6000
359	137,45	0,33	8,3	1315	6000	6000
359	177,55	0,26	6,4	1336	6000	6000

IS053

Mn ₂ [Nm]	i	Pn ₁ [kW]	n ₂ [rpm]	Fr1 [N]	Fr2 D [N]	Fr2 C-L [N]
359	198,45	0,23	5,7	1343	6000	6000
359	217,64	0,21	5,2	1349	6000	6000
359	256,33	0,18	4,5	1357	6000	6000
359	314,21	0,14	3,6	1367	6000	6000

IS062

Mn ₂ [Nm]	i	Pn ₁ [kW]	n ₂ [rpm]	Fr1 [N]	Fr2 D [N]	Fr2 C-L [N]
338	8,00	5,26	142,5	323	5686	2275
338	8,92	4,71	127,8	435	5973	2389
369	9,55	4,81	119,4	416	5962	2385
369	10,65	4,31	107,1	519	6266	2506
400	11,71	4,25	97,4	532	6346	2538
431	13,06	4,10	87,3	562	6476	2590
431	13,36	4,01	85,3	581	6545	2618
461	15,94	3,60	71,5	666	6907	2763
461	16,16	3,55	70,5	676	6952	2781
461	19,29	2,97	59,1	795	7545	3018
472	19,55	3,00	58,3	790	7527	3011
482	23,18	2,58	49,2	875	8070	3228
482	23,75	2,52	48,0	888	8160	3264
492	25,14	2,43	45,3	906	8308	3323
492	27,66	2,21	41,2	952	8673	3469
513	30,00	2,12	38,0	970	8864	3545
554	33,93	2,03	33,6	990	9105	3642
615	36,57	2,09	31,2	977	9032	3613
615	39,38	1,94	28,9	1008	9351	3740
615	43,64	1,75	26,1	1047	9808	3923
615	46,10	1,66	24,7	1066	10000	4000
615	48,30	1,58	23,6	1082	10000	4000
615	53,53	1,43	21,3	1114	10000	4000
615	55,00	1,39	20,7	1122	10000	4000
615	67,47	1,13	16,9	1175	10000	4000

IS063

Mn ₂ [Nm]	i	Pn ₁ [kW]	n ₂ [rpm]	Fr1 [N]	Fr2 D [N]	Fr2 C-L [N]
615	33,57	2,33	34,0	939	8672	3469
615	37,77	2,07	30,2	991	9171	3668
615	40,05	1,95	28,5	1015	9426	3770
615	49,13	1,59	23,2	1088	10000	4000

IS063

Mn_2 [Nm]	i	Pn_1 [kW]	n_2 [rpm]	Fr1 [N]	Fr2 D [N]	Fr2 C-L [N]
615	55,29	1,41	20,6	1123	10000	4000
615	58,72	1,33	19,4	1140	10000	4000
615	65,85	1,19	17,3	1169	10000	4000
615	68,25	1,14	16,7	1178	10000	4000
615	73,63	1,06	15,5	1194	10000	4000
615	81,43	0,96	14,0	1215	10000	4000
615	99,89	0,78	11,4	1251	10000	4000
615	126,43	0,62	9,0	1284	10000	4000
615	150,85	0,52	7,6	1304	10000	4000
615	182,53	0,43	6,2	1322	10000	4000
615	185,05	0,42	6,2	1324	10000	4000
615	217,79	0,36	5,2	1336	10000	4000
615	267,16	0,29	4,3	1350	10000	4000

IS082

Mn_2 [Nm]	i	Pn_1 [kW]	n_2 [rpm]	Fr1 [N]	Fr2 D [N]	Fr2 C-L [N]
564	7,34	9,55	155,3	1218	12956	3702
615	8,06	9,48	141,4	1230	13254	3787
666	9,94	8,33	114,6	1444	14180	4052
718	11,61	7,69	98,2	1563	14869	4248
769	12,75	7,50	89,4	1599	15243	4355
779	14,04	6,90	81,2	1710	15785	4510
789	15,43	6,36	73,9	1809	16330	4666
789	15,73	6,24	72,5	1831	16449	4700
789	17,29	5,67	65,9	1936	17056	4873
789	19,03	5,16	59,9	2032	17686	5053
789	20,14	4,87	56,6	2085	18000	5163
820	22,13	4,61	51,5	2134	18000	5320
820	24,00	4,25	47,5	2200	18000	5485
820	26,05	3,91	43,8	2262	18000	5657
923	27,29	4,20	41,8	2209	18000	5660
923	28,67	4,00	39,8	2246	18000	5767
923	29,60	3,88	38,5	2269	18000	5837
1025	31,78	4,01	35,9	2244	18000	5900
1025	34,91	3,65	32,7	2311	18000	6116
1025	35,50	3,59	32,1	2322	18000	6156
1025	40,05	3,18	28,5	2398	18000	6445
1025	43,05	2,96	26,5	2439	18000	6624
1025	50,25	2,54	22,7	2517	18000	7020
1025	54,27	2,35	21,0	2552	18000	7200
1025	61,98	2,06	18,4	2606	18000	7200

IS083

Mn ₂ [Nm]	i	Pn ₁ [kW]	n ₂ [rpm]	Fr1 [N]	Fr2 D [N]	Fr2 C-L [N]
1025	67,52	1,93	16,9	2638	18000	7200
1025	74,18	1,75	15,4	2669	18000	7200
1025	81,71	1,59	13,9	2698	18000	7200
1025	91,49	1,42	12,5	2729	18000	7200
1025	100,62	1,29	11,3	2753	18000	7200
1025	117,17	1,11	9,7	2786	18000	7200
1025	128,73	1,01	8,9	2804	18000	7200
1025	136,34	0,95	8,4	2814	18000	7200
1025	158,76	0,82	7,2	2838	18000	7200
1025	184,88	0,70	6,2	2859	18000	7200
1025	203,11	0,64	5,6	2871	18000	7200
1025	205,34	0,63	5,5	2872	18000	7200
1025	226,04	0,58	5,0	2883	18000	7200
1025	250,50	0,52	4,5	2893	18000	7200
1025	266,13	0,49	4,3	2898	18000	7200
1025	292,36	0,45	3,9	2906	18000	7200
1025	315,73	0,41	3,6	2912	18000	7200
1025	360,58	0,36	3,2	2922	18000	7200

IS102

Mn ₂ [Nm]	i	Pn ₁ [kW]	n ₂ [rpm]	Fr1 [N]	Fr2 D [N]	Fr2 C-L [N]
871	8,06	13,44	141,4	589	16327	4665
923	8,85	12,97	128,9	673	16772	4792
974	10,88	11,12	104,7	1002	17996	5142
1025	12,75	10,00	89,4	1203	18963	5418
1230	13,99	10,93	81,5	1036	19103	5458
1281	15,43	10,33	73,9	1144	19702	5629
1333	17,21	9,63	66,2	1269	20416	5833
1435	19,00	9,39	60,0	1311	20941	5983
1435	20,83	8,57	54,7	1459	21700	6200
1435	22,13	8,06	51,5	1548	22000	6346
1538	24,28	7,88	47,0	1582	22000	6501
1538	26,33	7,26	43,3	1692	22000	6709
1538	29,87	6,40	38,2	1845	22000	7042
1538	32,40	5,90	35,2	1935	22000	7264
1435	34,91	5,11	32,7	2076	22000	7550
1538	38,30	4,99	29,8	2097	22000	7742
1435	42,53	4,20	26,8	2239	22000	8129
1333	44,00	3,77	25,9	2316	22000	8309
1640	47,13	4,33	24,2	2216	22000	8295
1435	50,25	3,55	22,7	2355	22000	8650

IS102

Mn ₂ [Nm]	i	Pn ₁ [kW]	n ₂ [rpm]	Fr1 [N]	Fr2 D [N]	Fr2 C-L [N]
1333	55,14	3,01	20,7	2452	22000	9000
1640	59,40	3,43	19,2	2376	22000	9000
1640	67,84	3,01	16,8	2452	22000	9000

IS103

Mn ₂ [Nm]	i	Pn ₁ [kW]	n ₂ [rpm]	Fr1 [N]	Fr2 D [N]	Fr2 C-L [N]
1640	74,18	2,81	15,4	2498	22000	9000
1640	81,39	2,56	14,0	2541	22000	9000
1640	89,77	2,32	12,7	2583	22000	9000
1640	100,15	2,08	11,4	2625	22000	9000
1640	110,55	1,88	10,3	2659	22000	9000
1640	121,29	1,72	9,4	2689	22000	9000
1640	128,73	1,62	8,9	2706	22000	9000
1640	141,24	1,47	8,1	2731	22000	9000
1640	173,78	1,20	6,6	2779	22000	9000
1640	188,51	1,10	6,0	2796	22000	9000
1640	203,11	1,03	5,6	2810	22000	9000
1640	222,85	0,93	5,1	2825	22000	9000
1640	224,76	0,93	5,1	2827	22000	9000
1640	274,20	0,76	4,2	2856	22000	9000
1640	280,89	0,74	4,1	2859	22000	9000
1640	292,36	0,71	3,9	2864	22000	9000
1640	320,79	0,65	3,5	2875	22000	9000
1640	345,60	0,60	3,3	2883	22000	9000
1640	394,69	0,53	2,9	2897	22000	9000

IS122

Mn ₂ [Nm]	i	Pn ₁ [kW]	n ₂ [rpm]	Fr1 [N]	Fr2 D [N]	Fr2 C-L [N]
1538	8,48	22,54	134,4	2925	21217	6062
1743	9,30	23,30	122,6	2890	21272	6078
1743	10,24	21,16	111,3	2989	22173	6335
1948	11,42	21,21	99,9	2987	22449	6414
2255	12,63	22,21	90,3	2941	22293	6369
2460	13,84	22,10	82,4	2945	22464	6418
2665	16,99	19,50	67,1	3066	23915	6833
2870	21,25	16,79	53,6	3190	25743	7355
2870	22,37	15,96	51,0	3229	26367	7533
2973	23,29	15,87	48,9	3233	26480	7566
3075	26,15	14,62	43,6	3291	27563	7875

IS122

Mn ₂ [Nm]	i	Pn ₁ [kW]	n ₂ [rpm]	Fr1 [N]	Fr2 D [N]	Fr2 C-L [N]
3075	28,60	13,37	39,9	3349	28737	8211
3075	30,51	12,53	37,4	3387	29609	8460
3075	32,76	11,67	34,8	3427	30000	8739
3075	33,44	11,43	34,1	3438	30000	8822
3075	35,20	10,86	32,4	3464	30000	9029
3075	41,07	9,31	27,8	3536	30000	9674
3075	43,60	8,77	26,1	3561	30000	9933
2460	44,63	6,85	25,5	3649	30000	10701
2460	49,04	6,24	23,2	3678	30000	11123
2665	53,75	6,17	21,2	3681	30000	11200
3075	66,00	5,79	17,3	3698	30000	11200

IS123

Mn ₂ [Nm]	i	Pn ₁ [kW]	n ₂ [rpm]	Fr1 [N]	Fr2 D [N]	Fr2 C-L [N]
2768	64,84	5,42	17,6	3721	30000	11200
2768	71,07	4,95	16,0	3742	30000	11200
3075	78,46	4,98	14,5	3741	30000	11200
3075	87,27	4,47	13,1	3763	30000	11200
3075	105,91	3,69	10,8	3799	30000	11200
3075	112,52	3,47	10,1	3809	30000	11200
3075	123,33	3,17	9,2	3822	30000	11200
3075	130,04	3,00	8,8	3830	30000	11200
3075	133,78	2,92	8,5	3834	30000	11200
3075	151,43	2,58	7,5	3849	30000	11200
3075	177,53	2,20	6,4	3866	30000	11200
3075	194,59	2,01	5,9	3875	30000	11200
3075	215,60	1,81	5,3	3884	30000	11200
3075	238,93	1,63	4,8	3892	30000	11200

IS142

Mn ₂ [Nm]	i	Pn ₁ [kW]	n ₂ [rpm]	Fr1 [N]	Fr2 D [N]	Fr2 C-L [N]
1424	4,12	43,00	276,9	2336	22702	12973
1587	4,59	43,03	248,6	2334	22644	12940
1781	5,14	43,05	221,6	2333	22472	12841
2013	5,82	43,02	195,9	2335	22158	12662
2152	6,21	43,06	183,5	2332	21896	12512
1963	7,32	33,36	155,8	2909	25537	14593
2202	8,21	33,37	138,9	2909	25236	14420
2492	9,29	33,38	122,8	2908	24718	14124

IS142

Mn ₂ [Nm]	i	Pn ₁ [kW]	n ₂ [rpm]	Fr1 [N]	Fr2 D [N]	Fr2 C-L [N]
2662	9,91	33,39	115,0	2908	24353	13916
2886	11,41	31,47	100,0	3022	24729	14131
2686	12,81	26,06	89,0	3343	28171	16098
2501	14,27	21,79	79,9	3597	31412	17950
2718	16,01	21,12	71,2	3637	31675	18100
3075	18,11	21,11	63,0	3637	31068	17753
3284	19,33	21,12	59,0	3637	30628	17502
3398	22,24	18,99	51,2	3763	32406	18500
2968	25,26	14,61	45,1	4024	35000	18500
3329	28,33	14,61	40,2	4024	35000	18500
3766	32,05	14,61	35,6	4024	35000	18500
4021	34,22	14,61	33,3	4024	35000	18500
4542	39,38	14,34	28,9	4040	35000	18500

IS143

Mn ₂ [Nm]	i	Pn ₁ [kW]	n ₂ [rpm]	Fr1 [N]	Fr2 D [N]	Fr2 C-L [N]
4113	45,77	11,41	24,9	4200	35000	18500
4582	50,97	11,41	22,4	4200	35000	18500
4853	57,17	10,78	19,9	4200	35000	18500
4894	64,68	9,61	17,6	4200	35000	18500
4998	69,06	9,19	16,5	4200	35000	18500
4339	79,45	6,94	14,3	4200	35000	18500
4551	98,81	5,85	11,5	4200	35000	18500
4852	110,05	5,60	10,4	4200	35000	18500
4873	123,44	5,01	9,2	4200	35000	18500
4962	139,64	4,51	8,2	4200	35000	18500
4905	149,10	4,18	7,7	4200	35000	18500
3896	157,49	3,14	7,2	4200	35000	18500
4786	171,55	3,54	6,7	4200	35000	18500
4340	175,41	3,14	6,5	4200	35000	18500
4867	196,74	3,14	5,8	4200	35000	18500
4833	222,57	2,76	5,1	4200	35000	18500
5004	237,63	2,67	4,8	4200	35000	18500
4912	273,41	2,28	4,2	4200	35000	18500

IS152

Mn ₂ [Nm]	i	Pn ₁ [kW]	n ₂ [rpm]	Fr1 [N]	Fr2 D [N]	Fr2 C-L [N]
2638	4,06	80,75	280,7	2730	27495	15711
2943	4,53	80,73	251,5	2731	27481	15703

IS152

Mn_2 [Nm]	i	Pn_1 [kW]	n_2 [rpm]	$Fr1$ [N]	$Fr2$ D [N]	$Fr2$ C-L [N]
2987	5,20	71,37	219,1	3068	29222	16698
3016	5,71	65,65	199,6	3275	30453	17402
3152	6,52	60,08	174,8	3476	31812	18178
3340	7,28	57,06	156,6	3585	32628	18645
3619	8,36	53,85	136,4	3701	33540	19166
3845	9,17	52,12	124,3	3763	34029	19400
4287	10,42	51,16	109,4	3798	34121	19400
3388	12,46	33,81	91,5	4424	40000	19400
3780	13,91	33,79	82,0	4425	40000	19400
4340	15,97	33,80	71,4	4425	40000	19400
4764	17,53	33,80	65,0	4424	40000	19400
5412	19,91	33,80	57,3	4424	40000	19400
6222	22,88	33,81	49,8	4424	40000	19400
6241	27,11	28,63	42,1	4611	40000	19400
6852	29,75	28,64	38,3	4611	40000	19400
7782	33,79	28,64	33,7	4611	40000	19400
7881	38,84	25,23	29,4	4734	40000	19400

IS153

Mn_2 [Nm]	i	Pn_1 [kW]	n_2 [rpm]	$Fr1$ [N]	$Fr2$ D [N]	$Fr2$ C-L [N]
6438	40,10	20,39	28,4	4924	40000	19400
7185	44,76	20,39	25,5	4924	40000	19400
8062	51,38	19,93	22,2	4940	40000	19400
8460	56,39	19,05	20,2	4971	40000	19400
9015	64,05	17,87	17,8	5013	40000	19400
7974	73,63	13,75	15,5	5158	40000	19400
7283	87,16	10,61	13,1	5200	40000	19400
8129	97,27	10,61	11,7	5200	40000	19400
9331	111,67	10,61	10,2	5200	40000	19400
9775	122,57	10,13	9,3	5200	40000	19400
9370	139,21	8,55	8,2	5200	40000	19400
7307	154,02	6,02	7,4	5200	40000	19400
8286	160,02	6,58	7,1	5200	40000	19400
8389	176,81	6,02	6,5	5200	40000	19400
9206	194,06	6,02	5,9	5200	40000	19400
9587	220,42	5,52	5,2	5200	40000	19400
8486	253,36	4,25	4,5	5200	40000	19400

IS052

Mn ₂ [Nm]	i	Pn ₁ [kW]	n ₂ [rpm]	Fr1 [N]	Fr2 D [N]	Fr2 C-L [N]
179	8,63	2,01	104,3	683	4011	4011
200	11,14	1,74	80,8	781	4334	4334
210	12,00	1,70	75,0	795	4409	4409
221	13,66	1,57	65,9	842	4593	4593
252	15,27	1,60	58,9	830	4631	4631
252	16,29	1,50	55,3	866	4762	4762
252	18,63	1,31	48,3	934	5045	5045
252	19,73	1,24	45,6	960	5169	5169
273	21,04	1,26	42,8	953	5189	5189
273	21,53	1,23	41,8	963	5241	5241
273	24,07	1,10	37,4	1010	5496	5496
305	25,20	1,17	35,7	984	5422	5422
305	25,79	1,15	34,9	994	5476	5476
305	27,81	1,06	32,4	1024	5659	5659
305	30,00	0,99	30,0	1052	5848	5848
315	32,55	0,94	27,6	1068	5994	5994
315	33,00	0,93	27,3	1073	6000	6000
315	34,09	0,90	26,4	1083	6000	6000
347	36,55	0,92	24,6	1075	6000	6000
347	38,75	0,87	23,2	1094	6000	6000
368	39,90	0,90	22,6	1084	6000	6000
368	42,63	0,84	21,1	1105	6000	6000
368	46,00	0,78	19,6	1127	6000	6000
368	47,20	0,76	19,1	1134	6000	6000
368	52,25	0,68	17,2	1161	6000	6000
368	57,86	0,62	15,6	1184	6000	6000
368	59,42	0,60	15,2	1190	6000	6000
368	72,83	0,49	12,4	1230	6000	6000

IS053

Mn ₂ [Nm]	i	Pn ₁ [kW]	n ₂ [rpm]	Fr1 [N]	Fr2 D [N]	Fr2 C-L [N]
368	36,50	1,00	24,7	1054	5991	5991
368	47,14	0,77	19,1	1134	6000	6000
368	57,79	0,63	15,6	1184	6000	6000
368	63,74	0,57	14,1	1205	6000	6000
368	74,20	0,49	12,1	1233	6000	6000
368	78,14	0,47	11,5	1242	6000	6000
368	95,84	0,38	9,4	1272	6000	6000
368	117,48	0,31	7,7	1297	6000	6000
368	137,45	0,27	6,5	1313	6000	6000
368	177,55	0,21	5,1	1334	6000	6000

IS053

Mn ₂ [Nm]	i	Pn ₁ [kW]	n ₂ [rpm]	Fr1 [N]	Fr2 D [N]	Fr2 C-L [N]
368	198,45	0,18	4,5	1342	6000	6000
368	217,64	0,17	4,1	1347	6000	6000
368	256,33	0,14	3,5	1356	6000	6000
368	314,21	0,12	2,9	1366	6000	6000

IS062

Mn ₂ [Nm]	i	Pn ₁ [kW]	n ₂ [rpm]	Fr1 [N]	Fr2 D [N]	Fr2 C-L [N]
347	8,00	4,21	112,5	297	6269	2508
347	8,92	3,77	100,9	412	6580	2632
378	9,55	3,85	94,3	392	6578	2631
378	10,65	3,45	84,5	497	6907	2763
410	11,71	3,40	76,9	511	7004	2802
441	13,06	3,28	68,9	542	7156	2862
441	13,36	3,21	67,4	561	7231	2892
473	15,94	2,88	56,5	648	7633	3053
473	16,16	2,84	55,7	658	7682	3073
473	19,29	2,38	46,7	780	8323	3329
483	19,55	2,40	46,0	775	8308	3323
494	23,18	2,07	38,8	862	8898	3559
494	23,75	2,02	37,9	875	8995	3598
504	25,14	1,95	35,8	894	9159	3663
504	27,66	1,77	32,5	941	9553	3821
525	30,00	1,70	30,0	960	9767	3907
567	33,93	1,62	26,5	980	10000	4000
630	36,57	1,67	24,6	967	9986	3994
630	39,38	1,56	22,9	998	10000	4000
630	43,64	1,40	20,6	1038	10000	4000
630	46,10	1,33	19,5	1058	10000	4000
630	48,30	1,27	18,6	1074	10000	4000
630	53,53	1,14	16,8	1107	10000	4000
630	55,00	1,11	16,4	1115	10000	4000
630	67,47	0,91	13,3	1169	10000	4000

IS063

Mn ₂ [Nm]	i	Pn ₁ [kW]	n ₂ [rpm]	Fr1 [N]	Fr2 D [N]	Fr2 C-L [N]
630	33,57	1,86	26,8	927	9596	3839
630	37,77	1,66	23,8	981	10000	4000
630	40,05	1,56	22,5	1005	10000	4000
630	49,13	1,27	18,3	1080	10000	4000

IS063

Mn ₂ [Nm]	i	Pn ₁ [kW]	n ₂ [rpm]	Fr1 [N]	Fr2 D [N]	Fr2 C-L [N]
630	55,29	1,13	16,3	1116	10000	4000
630	58,72	1,07	15,3	1133	10000	4000
630	65,85	0,95	13,7	1163	10000	4000
630	68,25	0,92	13,2	1172	10000	4000
630	73,63	0,85	12,2	1189	10000	4000
630	81,43	0,77	11,1	1210	10000	4000
630	99,89	0,63	9,0	1247	10000	4000
630	126,43	0,49	7,1	1281	10000	4000
630	150,85	0,41	6,0	1302	10000	4000
630	182,53	0,34	4,9	1320	10000	4000
630	185,05	0,34	4,9	1321	10000	4000
630	217,79	0,29	4,1	1335	10000	4000
630	267,16	0,23	3,4	1348	10000	4000

IS082

Mn ₂ [Nm]	i	Pn ₁ [kW]	n ₂ [rpm]	Fr1 [N]	Fr2 D [N]	Fr2 C-L [N]
578	7,34	7,65	122,6	1175	14112	4032
630	8,06	7,59	111,6	1188	14444	4127
683	9,94	6,67	90,5	1406	15455	4416
735	11,61	6,16	77,5	1529	16209	4631
788	12,75	6,00	70,6	1565	16623	4749
798	14,04	5,52	64,1	1678	17211	4917
809	15,43	5,09	58,3	1780	17802	5086
809	15,73	5,00	57,2	1803	17931	5123
809	17,29	4,54	52,0	1910	18000	5311
809	19,03	4,13	47,3	2009	18000	5505
809	20,14	3,90	44,7	2063	18000	5623
840	22,13	3,69	40,7	2113	18000	5795
840	24,00	3,40	37,5	2181	18000	5974
840	26,05	3,13	34,5	2244	18000	6159
945	27,29	3,37	33,0	2190	18000	6168
945	28,67	3,20	31,4	2228	18000	6285
945	29,60	3,10	30,4	2252	18000	6360
1050	31,78	3,21	28,3	2226	18000	6433
1050	34,91	2,92	25,8	2294	18000	6667
1050	35,50	2,87	25,4	2306	18000	6710
1050	40,05	2,55	22,5	2383	18000	7022
1050	43,05	2,37	20,9	2425	18000	7200
1050	50,25	2,03	17,9	2506	18000	7200
1050	54,27	1,88	16,6	2542	18000	7200
1050	61,98	1,65	14,5	2597	18000	7200

IS083

Mn ₂ [Nm]	i	Pn ₁ [kW]	n ₂ [rpm]	Fr1 [N]	Fr2 D [N]	Fr2 C-L [N]
1050	67,52	1,54	13,3	2629	18000	7200
1050	74,18	1,41	12,1	2661	18000	7200
1050	81,71	1,28	11,0	2691	18000	7200
1050	91,49	1,14	9,8	2723	18000	7200
1050	100,62	1,04	8,9	2747	18000	7200
1050	117,17	0,89	7,7	2781	18000	7200
1050	128,73	0,81	7,0	2799	18000	7200
1050	136,34	0,76	6,6	2810	18000	7200
1050	158,76	0,66	5,7	2835	18000	7200
1050	184,88	0,56	4,9	2856	18000	7200
1050	203,11	0,51	4,4	2868	18000	7200
1050	205,34	0,51	4,4	2869	18000	7200
1050	226,04	0,46	4,0	2880	18000	7200
1050	250,50	0,42	3,6	2891	18000	7200
1050	266,13	0,39	3,4	2896	18000	7200
1050	292,36	0,36	3,1	2904	18000	7200
1050	315,73	0,33	2,9	2911	18000	7200
1050	360,58	0,29	2,5	2920	18000	7200

IS102

Mn ₂ [Nm]	i	Pn ₁ [kW]	n ₂ [rpm]	Fr1 [N]	Fr2 D [N]	Fr2 C-L [N]
893	8,06	10,76	111,6	530	17780	5080
945	8,85	10,38	101,7	616	18268	5220
998	10,88	8,91	82,7	953	19599	5600
1050	12,75	8,00	70,6	1160	20652	5901
1260	13,99	8,75	64,3	988	20834	5953
1313	15,43	8,27	58,3	1099	21489	6140
1365	17,21	7,71	52,3	1227	22000	6362
1470	19,00	7,52	47,4	1270	22000	6529
1470	20,83	6,86	43,2	1421	22000	6763
1470	22,13	6,46	40,7	1513	22000	6922
1575	24,28	6,31	37,1	1548	22000	7093
1575	26,33	5,81	34,2	1660	22000	7318
1575	29,87	5,13	30,1	1818	22000	7678
1575	32,40	4,72	27,8	1909	22000	7918
1470	34,91	4,09	25,8	2054	22000	8223
1575	38,30	4,00	23,5	2076	22000	8434
1470	42,53	3,36	21,2	2221	22000	8849
1365	44,00	3,02	20,4	2300	22000	9000
1680	47,13	3,46	19,1	2197	22000	9000
1470	50,25	2,84	17,9	2339	22000	9000

IS102

Mn ₂ [Nm]	i	Pn ₁ [kW]	n ₂ [rpm]	Fr1 [N]	Fr2 D [N]	Fr2 C-L [N]
1365	55,14	2,41	16,3	2439	22000	9000
1680	59,40	2,75	15,2	2361	22000	9000
1680	67,84	2,41	13,3	2439	22000	9000

IS103

Mn ₂ [Nm]	i	Pn ₁ [kW]	n ₂ [rpm]	Fr1 [N]	Fr2 D [N]	Fr2 C-L [N]
1680	74,18	2,25	12,1	2486	22000	9000
1680	81,39	2,05	11,1	2530	22000	9000
1680	89,77	1,86	10,0	2573	22000	9000
1680	100,15	1,67	9,0	2616	22000	9000
1680	110,55	1,51	8,1	2651	22000	9000
1680	121,29	1,37	7,4	2681	22000	9000
1680	128,73	1,30	7,0	2699	22000	9000
1680	141,24	1,18	6,4	2725	22000	9000
1680	173,78	0,96	5,2	2774	22000	9000
1680	188,51	0,88	4,8	2791	22000	9000
1680	203,11	0,82	4,4	2805	22000	9000
1680	222,85	0,75	4,0	2821	22000	9000
1680	224,76	0,74	4,0	2823	22000	9000
1680	274,20	0,61	3,3	2853	22000	9000
1680	280,89	0,59	3,2	2856	22000	9000
1680	292,36	0,57	3,1	2861	22000	9000
1680	320,79	0,52	2,8	2873	22000	9000
1680	345,60	0,48	2,6	2881	22000	9000
1680	394,69	0,42	2,3	2894	22000	9000

IS122

Mn ₂ [Nm]	i	Pn ₁ [kW]	n ₂ [rpm]	Fr1 [N]	Fr2 D [N]	Fr2 C-L [N]
1575	8,48	18,05	106,1	2900	23269	6648
1785	9,30	18,66	96,8	2864	23372	6678
1785	10,24	16,95	87,9	2965	24346	6956
1995	11,42	16,99	78,8	2963	24689	7054
2310	12,63	17,78	71,3	2916	24586	7025
2520	13,84	17,70	65,0	2921	24815	7090
2730	16,99	15,61	53,0	3044	26428	7551
2940	21,25	13,45	42,4	3172	28448	8128
2940	22,37	12,78	40,2	3211	29123	8321
3045	23,29	12,71	38,6	3215	29267	8362
3150	26,15	11,71	34,4	3274	30000	8703

IS122

Mn ₂ [Nm]	i	Pn ₁ [kW]	n ₂ [rpm]	Fr1 [N]	Fr2 D [N]	Fr2 C-L [N]
3150	28,60	10,71	31,5	3333	30000	9066
3150	30,51	10,03	29,5	3373	30000	9335
3150	32,76	9,35	27,5	3414	30000	9637
3150	33,44	9,15	26,9	3425	30000	9727
3150	35,20	8,70	25,6	3452	30000	9950
3150	41,07	7,46	21,9	3525	30000	10647
3150	43,60	7,02	20,6	3551	30000	10928
2520	44,63	5,49	20,2	3642	30000	11200
2520	49,04	4,99	18,4	3671	30000	11200
2730	53,75	4,94	16,7	3674	30000	11200
3150	66,00	4,64	13,6	3692	30000	11200

IS123

Mn ₂ [Nm]	i	Pn ₁ [kW]	n ₂ [rpm]	Fr1 [N]	Fr2 D [N]	Fr2 C-L [N]
2835	64,84	4,34	13,9	3715	30000	11200
2835	71,07	3,96	12,7	3737	30000	11200
3150	78,46	3,99	11,5	3735	30000	11200
3150	87,27	3,58	10,3	3758	30000	11200
3150	105,91	2,95	8,5	3795	30000	11200
3150	112,52	2,78	8,0	3805	30000	11200
3150	123,33	2,54	7,3	3819	30000	11200
3150	130,04	2,40	6,9	3827	30000	11200
3150	133,78	2,34	6,7	3830	30000	11200
3150	151,43	2,06	5,9	3846	30000	11200
3150	177,53	1,76	5,1	3864	30000	11200
3150	194,59	1,61	4,6	3873	30000	11200
3150	215,60	1,45	4,2	3882	30000	11200
3150	238,93	1,31	3,8	3890	30000	11200

IS142

Mn ₂ [Nm]	i	Pn ₁ [kW]	n ₂ [rpm]	Fr1 [N]	Fr2 D [N]	Fr2 C-L [N]
1458	4,12	34,43	218,6	2274	25181	14389
1626	4,59	34,45	196,2	2272	25192	14395
1824	5,14	34,47	175,0	2270	25092	14338
2062	5,82	34,44	154,7	2273	24856	14204
2204	6,21	34,48	144,9	2270	24635	14077
2011	7,32	26,71	123,0	2861	28487	16279
2256	8,21	26,72	109,7	2860	28268	16153
2553	9,29	26,73	96,9	2860	27839	15908

IS142

Mn ₂ [Nm]	i	Pn ₁ [kW]	n ₂ [rpm]	Fr1 [N]	Fr2 D [N]	Fr2 C-L [N]
2727	9,91	26,73	90,8	2859	27520	15726
2957	11,41	25,20	78,9	2976	28027	16015
2751	12,81	20,87	70,2	3305	31658	18090
2562	14,27	17,45	63,1	3565	35000	18500
2784	16,01	16,91	56,2	3606	35000	18500
3150	18,11	16,91	49,7	3607	34964	18500
3364	19,33	16,91	46,5	3606	34583	18500
3481	22,24	15,21	40,5	3736	35000	18500
3041	25,26	11,70	35,6	4003	35000	18500
3410	28,33	11,70	31,8	4003	35000	18500
3858	32,05	11,70	28,1	4003	35000	18500
4119	34,22	11,70	26,3	4003	35000	18500
4652	39,38	11,48	22,9	4019	35000	18500

IS143

Mn ₂ [Nm]	i	Pn ₁ [kW]	n ₂ [rpm]	Fr1 [N]	Fr2 D [N]	Fr2 C-L [N]
4214	45,77	9,14	19,7	4200	35000	18500
4693	50,97	9,14	17,7	4200	35000	18500
4971	57,17	8,63	15,7	4200	35000	18500
5013	64,68	7,69	13,9	4200	35000	18500
5120	69,06	7,36	13,0	4200	35000	18500
4445	79,45	5,55	11,3	4200	35000	18500
4662	98,81	4,68	9,1	4200	35000	18500
4970	110,05	4,48	8,2	4200	35000	18500
4992	123,44	4,01	7,3	4200	35000	18500
5083	139,64	3,61	6,4	4200	35000	18500
5025	149,10	3,35	6,0	4200	35000	18500
3991	157,49	2,52	5,7	4200	35000	18500
4903	171,55	2,84	5,2	4200	35000	18500
4446	175,41	2,52	5,1	4200	35000	18500
4986	196,74	2,52	4,6	4200	35000	18500
4951	222,57	2,21	4,0	4200	35000	18500
5126	237,63	2,14	3,8	4200	35000	18500
5031	273,41	1,83	3,3	4200	35000	18500

IS152

Mn ₂ [Nm]	i	Pn ₁ [kW]	n ₂ [rpm]	Fr1 [N]	Fr2 D [N]	Fr2 C-L [N]
2702	4,06	64,66	221,6	2659	30466	17409
3015	4,53	64,64	198,6	2660	30536	17449

IS152

Mn_2 [Nm]	i	Pn_1 [kW]	n2 [rpm]	Fr1 [N]	Fr2 D [N]	Fr2 C-L [N]
3060	5,20	57,15	172,9	3005	32431	18532
3089	5,71	52,57	157,6	3217	33770	19297
3229	6,52	48,11	138,0	3423	35277	19400
3422	7,28	45,69	123,6	3535	36213	19400
3708	8,36	43,12	107,7	3653	37277	19400
3939	9,17	41,73	98,1	3717	37869	19400
4391	10,42	40,96	86,4	3753	38092	19400
3471	12,46	27,07	72,2	4394	40000	19400
3872	13,91	27,06	64,7	4395	40000	19400
4446	15,97	27,06	56,4	4395	40000	19400
4881	17,53	27,07	51,4	4395	40000	19400
5544	19,91	27,07	45,2	4394	40000	19400
6374	22,88	27,07	39,3	4394	40000	19400
6394	27,11	22,93	33,2	4586	40000	19400
7019	29,75	22,93	30,2	4585	40000	19400
7972	33,79	22,93	26,6	4586	40000	19400
8073	38,84	20,20	23,2	4711	40000	19400

IS153

Mn_2 [Nm]	i	Pn_1 [kW]	n2 [rpm]	Fr1 [N]	Fr2 D [N]	Fr2 C-L [N]
6595	40,10	16,33	22,4	4906	40000	19400
7360	44,76	16,32	20,1	4906	40000	19400
8259	51,38	15,95	17,5	4923	40000	19400
8667	56,39	15,25	16,0	4955	40000	19400
9235	64,05	14,31	14,1	4997	40000	19400
8168	73,63	11,01	12,2	5146	40000	19400
7461	87,16	8,50	10,3	5200	40000	19400
8327	97,27	8,50	9,2	5200	40000	19400
9559	111,67	8,50	8,1	5200	40000	19400
10013	122,57	8,11	7,3	5200	40000	19400
9599	139,21	6,84	6,5	5200	40000	19400
7485	154,02	4,82	5,8	5200	40000	19400
8489	160,02	5,27	5,6	5200	40000	19400
8593	176,81	4,82	5,1	5200	40000	19400
9431	194,06	4,82	4,6	5200	40000	19400
9821	220,42	4,42	4,1	5200	40000	19400
8693	253,36	3,41	3,5	5200	40000	19400

IS052

Mn ₂ [Nm]	i	Pn ₁ [kW]	n ₂ [rpm]	Fr1 [N]	Fr2 D [N]	Fr2 C-L [N]
181	8,63	1,58	81,2	674	4435	4435
202	11,14	1,36	62,8	773	4795	4795
213	12,00	1,33	58,3	787	4881	4881
223	13,66	1,23	51,3	835	5086	5086
255	15,27	1,26	45,8	823	5141	5141
255	16,29	1,18	43,0	859	5283	5283
255	18,63	1,03	37,6	928	5590	5590
255	19,73	0,97	35,5	955	5725	5725
276	21,04	0,99	33,3	947	5756	5756
276	21,53	0,97	32,5	958	5812	5812
276	24,07	0,86	29,1	1005	6000	6000
308	25,20	0,92	27,8	979	6000	6000
308	25,79	0,90	27,1	989	6000	6000
308	27,81	0,83	25,2	1019	6000	6000
308	30,00	0,77	23,3	1047	6000	6000
319	32,55	0,74	21,5	1064	6000	6000
319	33,00	0,73	21,2	1069	6000	6000
319	34,09	0,70	20,5	1080	6000	6000
351	36,55	0,72	19,1	1071	6000	6000
351	38,75	0,68	18,1	1090	6000	6000
372	39,90	0,70	17,5	1081	6000	6000
372	42,63	0,66	16,4	1101	6000	6000
372	46,00	0,61	15,2	1124	6000	6000
372	47,20	0,59	14,8	1131	6000	6000
372	52,25	0,54	13,4	1158	6000	6000
372	57,86	0,48	12,1	1182	6000	6000
372	59,42	0,47	11,8	1188	6000	6000
372	72,83	0,38	9,6	1228	6000	6000

IS053

Mn ₂ [Nm]	i	Pn ₁ [kW]	n ₂ [rpm]	Fr1 [N]	Fr2 D [N]	Fr2 C-L [N]
372	36,50	0,78	19,2	1050	6000	6000
372	47,14	0,61	14,8	1131	6000	6000
372	57,79	0,49	12,1	1181	6000	6000
372	63,74	0,45	11,0	1203	6000	6000
372	74,20	0,39	9,4	1231	6000	6000
372	78,14	0,37	9,0	1240	6000	6000
372	95,84	0,30	7,3	1271	6000	6000
372	117,48	0,24	6,0	1296	6000	6000
372	137,45	0,21	5,1	1312	6000	6000
372	177,55	0,16	3,9	1333	6000	6000

IS053

Mn ₂ [Nm]	i	Pn ₁ [kW]	n ₂ [rpm]	Fr1 [N]	Fr2 D [N]	Fr2 C-L [N]
372	198,45	0,14	3,5	1341	6000	6000
372	217,64	0,13	3,2	1347	6000	6000
372	256,33	0,11	2,7	1356	6000	6000
372	314,21	0,09	2,2	1365	6000	6000

IS062

Mn ₂ [Nm]	i	Pn ₁ [kW]	n ₂ [rpm]	Fr1 [N]	Fr2 D [N]	Fr2 C-L [N]
351	8,00	3,30	87,5	284	6975	2790
351	8,92	2,96	78,5	400	7312	2925
383	9,55	3,01	73,3	380	7325	2930
383	10,65	2,70	65,8	486	7683	3073
414	11,71	2,66	59,8	500	7803	3121
446	13,06	2,57	53,6	531	7983	3193
446	13,36	2,51	52,4	551	8065	3226
478	15,94	2,26	43,9	639	8516	3407
478	16,16	2,23	43,3	649	8570	3428
478	19,29	1,86	36,3	772	9266	3706
489	19,55	1,88	35,8	767	9254	3702
499	23,18	1,62	30,2	856	9901	3960
499	23,75	1,58	29,5	869	10000	4000
510	25,14	1,53	27,8	888	10000	4000
510	27,66	1,39	25,3	935	10000	4000
531	30,00	1,33	23,3	954	10000	4000
574	33,93	1,27	20,6	975	10000	4000
638	36,57	1,31	19,1	961	10000	4000
638	39,38	1,22	17,8	993	10000	4000
638	43,64	1,10	16,0	1034	10000	4000
638	46,10	1,04	15,2	1054	10000	4000
638	48,30	0,99	14,5	1070	10000	4000
638	53,53	0,90	13,1	1103	10000	4000
638	55,00	0,87	12,7	1111	10000	4000
638	67,47	0,71	10,4	1166	10000	4000

IS063

Mn ₂ [Nm]	i	Pn ₁ [kW]	n ₂ [rpm]	Fr1 [N]	Fr2 D [N]	Fr2 C-L [N]
638	33,57	1,46	20,9	921	10000	4000
638	37,77	1,30	18,5	976	10000	4000
638	40,05	1,22	17,5	1000	10000	4000
638	49,13	1,00	14,2	1076	10000	4000

IS063

Mn ₂ [Nm]	i	Pn ₁ [kW]	n ₂ [rpm]	Fr1 [N]	Fr2 D [N]	Fr2 C-L [N]
638	55,29	0,89	12,7	1113	10000	4000
638	58,72	0,83	11,9	1130	10000	4000
638	65,85	0,74	10,6	1160	10000	4000
638	68,25	0,72	10,3	1169	10000	4000
638	73,63	0,67	9,5	1187	10000	4000
638	81,43	0,60	8,6	1208	10000	4000
638	99,89	0,49	7,0	1245	10000	4000
638	126,43	0,39	5,5	1279	10000	4000
638	150,85	0,32	4,6	1300	10000	4000
638	182,53	0,27	3,8	1319	10000	4000
638	185,05	0,26	3,8	1320	10000	4000
638	217,79	0,22	3,2	1334	10000	4000
638	267,16	0,18	2,6	1348	10000	4000

IS082

Mn ₂ [Nm]	i	Pn ₁ [kW]	n ₂ [rpm]	Fr1 [N]	Fr2 D [N]	Fr2 C-L [N]
584	7,34	5,99	95,4	1153	15474	4421
638	8,06	5,95	86,8	1166	15847	4528
691	9,94	5,22	70,4	1388	16959	4845
744	11,61	4,82	60,3	1511	17790	5083
797	12,75	4,70	54,9	1548	18000	5215
808	14,04	4,33	49,8	1663	18000	5399
818	15,43	3,99	45,4	1766	18000	5583
818	15,73	3,91	44,5	1789	18000	5623
818	17,29	3,56	40,5	1898	18000	5826
818	19,03	3,23	36,8	1997	18000	6038
818	20,14	3,06	34,8	2052	18000	6166
850	22,13	2,89	31,6	2102	18000	6355
850	24,00	2,66	29,2	2171	18000	6550
850	26,05	2,45	26,9	2236	18000	6751
956	27,29	2,64	25,6	2180	18000	6768
956	28,67	2,51	24,4	2219	18000	6894
956	29,60	2,43	23,6	2243	18000	6976
1063	31,78	2,52	22,0	2217	18000	7063
1063	34,91	2,29	20,1	2286	18000	7200
1063	35,50	2,25	19,7	2298	18000	7200
1063	40,05	2,00	17,5	2376	18000	7200
1063	43,05	1,86	16,3	2419	18000	7200
1063	50,25	1,59	13,9	2500	18000	7200
1063	54,27	1,47	12,9	2536	18000	7200
1063	61,98	1,29	11,3	2592	18000	7200

IS083

Mn ₂ [Nm]	i	Pn ₁ [kW]	n ₂ [rpm]	Fr1 [N]	Fr2 D [N]	Fr2 C-L [N]
1063	67,52	1,21	10,4	2625	18000	7200
1063	74,18	1,10	9,4	2657	18000	7200
1063	81,71	1,00	8,6	2688	18000	7200
1063	91,49	0,89	7,7	2720	18000	7200
1063	100,62	0,81	7,0	2744	18000	7200
1063	117,17	0,70	6,0	2778	18000	7200
1063	128,73	0,63	5,4	2797	18000	7200
1063	136,34	0,60	5,1	2808	18000	7200
1063	158,76	0,51	4,4	2833	18000	7200
1063	184,88	0,44	3,8	2855	18000	7200
1063	203,11	0,40	3,5	2867	18000	7200
1063	205,34	0,40	3,4	2868	18000	7200
1063	226,04	0,36	3,1	2879	18000	7200
1063	250,50	0,33	2,8	2889	18000	7200
1063	266,13	0,31	2,6	2895	18000	7200
1063	292,36	0,28	2,4	2903	18000	7200
1063	315,73	0,26	2,2	2910	18000	7200
1063	360,58	0,23	1,9	2919	18000	7200

IS102

Mn ₂ [Nm]	i	Pn ₁ [kW]	n ₂ [rpm]	Fr1 [N]	Fr2 D [N]	Fr2 C-L [N]
903	8,06	8,43	86,8	501	19490	5569
956	8,85	8,13	79,1	588	20031	5723
1009	10,88	6,98	64,3	929	21487	6139
1063	12,75	6,27	54,9	1138	22000	6469
1275	13,99	6,86	50,0	964	22000	6537
1328	15,43	6,48	45,4	1077	22000	6743
1381	17,21	6,04	40,7	1206	22000	6988
1488	19,00	5,89	36,8	1250	22000	7175
1488	20,83	5,37	33,6	1403	22000	7430
1488	22,13	5,06	31,6	1495	22000	7601
1594	24,28	4,94	28,8	1531	22000	7793
1594	26,33	4,55	26,6	1645	22000	8037
1594	29,87	4,01	23,4	1804	22000	8429
1594	32,40	3,70	21,6	1896	22000	8690
1488	34,91	3,21	20,1	2042	22000	9000
1594	38,30	3,13	18,3	2065	22000	9000
1488	42,53	2,63	16,5	2212	22000	9000
1381	44,00	2,36	15,9	2292	22000	9000
1700	47,13	2,71	14,8	2188	22000	9000
1488	50,25	2,23	13,9	2331	22000	9000

IS102

Mn_2 [Nm]	i	Pn_1 [kW]	n_2 [rpm]	Fr1 [N]	Fr2 D [N]	Fr2 C-L [N]
1381	55,14	1,88	12,7	2432	22000	9000
1700	59,40	2,15	11,8	2353	22000	9000
1700	67,84	1,89	10,3	2432	22000	9000

IS103

Mn_2 [Nm]	i	Pn_1 [kW]	n_2 [rpm]	Fr1 [N]	Fr2 D [N]	Fr2 C-L [N]
1700	74,18	1,76	9,4	2480	22000	9000
1700	81,39	1,60	8,6	2525	22000	9000
1700	89,77	1,45	7,8	2568	22000	9000
1700	100,15	1,30	7,0	2612	22000	9000
1700	110,55	1,18	6,3	2647	22000	9000
1700	121,29	1,08	5,8	2678	22000	9000
1700	128,73	1,01	5,4	2696	22000	9000
1700	141,24	0,92	5,0	2722	22000	9000
1700	173,78	0,75	4,0	2772	22000	9000
1700	188,51	0,69	3,7	2789	22000	9000
1700	203,11	0,64	3,5	2803	22000	9000
1700	222,85	0,59	3,1	2819	22000	9000
1700	224,76	0,58	3,1	2821	22000	9000
1700	274,20	0,48	2,5	2851	22000	9000
1700	280,89	0,46	2,5	2854	22000	9000
1700	292,36	0,45	2,4	2860	22000	9000
1700	320,79	0,41	2,2	2871	22000	9000
1700	345,60	0,38	2,0	2880	22000	9000
1700	394,69	0,33	1,8	2893	22000	9000

IS122

Mn_2 [Nm]	i	Pn_1 [kW]	n_2 [rpm]	Fr1 [N]	Fr2 D [N]	Fr2 C-L [N]
1594	8,48	14,13	82,5	2887	25726	7350
1806	9,30	14,61	75,3	2851	25898	7399
1806	10,24	13,27	68,4	2953	26956	7702
2019	11,42	13,30	61,3	2951	27388	7825
2338	12,63	13,93	55,4	2903	27364	7818
2550	13,84	13,86	50,6	2908	27673	7906
2763	16,99	12,23	41,2	3033	29485	8424
2975	21,25	10,53	32,9	3162	30000	9068
2975	22,37	10,01	31,3	3202	30000	9278
3081	23,29	9,95	30,1	3206	30000	9331
3188	26,15	9,17	26,8	3266	30000	9710

IS122

Mn ₂ [Nm]	i	Pn ₁ [kW]	n ₂ [rpm]	Fr1 [N]	Fr2 D [N]	Fr2 C-L [N]
3188	28,60	8,38	24,5	3326	30000	10104
3188	30,51	7,86	22,9	3366	30000	10396
3188	32,76	7,32	21,4	3407	30000	10724
3188	33,44	7,17	20,9	3419	30000	10822
3188	35,20	6,81	19,9	3446	30000	11065
3188	41,07	5,84	17,1	3520	30000	11200
3188	43,60	5,50	16,1	3546	30000	11200
2550	44,63	4,30	15,7	3638	30000	11200
2550	49,04	3,91	14,3	3667	30000	11200
2763	53,75	3,87	13,0	3671	30000	11200
3188	66,00	3,63	10,6	3688	30000	11200

IS123

Mn ₂ [Nm]	i	Pn ₁ [kW]	n ₂ [rpm]	Fr1 [N]	Fr2 D [N]	Fr2 C-L [N]
2869	64,84	3,40	10,8	3712	30000	11200
2869	71,07	3,10	9,8	3734	30000	11200
3188	78,46	3,12	8,9	3732	30000	11200
3188	87,27	2,81	8,0	3756	30000	11200
3188	105,91	2,31	6,6	3793	30000	11200
3188	112,52	2,18	6,2	3803	30000	11200
3188	123,33	1,99	5,7	3817	30000	11200
3188	130,04	1,88	5,4	3825	30000	11200
3188	133,78	1,83	5,2	3829	30000	11200
3188	151,43	1,62	4,6	3845	30000	11200
3188	177,53	1,38	3,9	3863	30000	11200
3188	194,59	1,26	3,6	3872	30000	11200
3188	215,60	1,14	3,2	3881	30000	11200
3188	238,93	1,02	2,9	3889	30000	11200

IS142

Mn ₂ [Nm]	i	Pn ₁ [kW]	n ₂ [rpm]	Fr1 [N]	Fr2 D [N]	Fr2 C-L [N]
1476	4,12	26,96	170,0	2243	28216	16124
1645	4,59	26,98	152,6	2241	28326	16186
1846	5,14	27,00	136,1	2239	28334	16191
2087	5,82	26,97	120,3	2241	28218	16125
2230	6,21	27,00	112,7	2239	28061	16035
2035	7,32	20,92	95,7	2836	32133	18362
2283	8,21	20,92	85,3	2836	32039	18308
2584	9,29	20,93	75,4	2835	31747	18141

IS142

Mn ₂ [Nm]	i	Pn ₁ [kW]	n ₂ [rpm]	Fr1 [N]	Fr2 D [N]	Fr2 C-L [N]
2759	9,91	20,94	70,6	2835	31503	18002
2992	11,41	19,73	61,4	2953	32189	18394
2784	12,81	16,34	54,6	3286	35000	18500
2593	14,27	13,67	49,0	3549	35000	18500
2818	16,01	13,24	43,7	3591	35000	18500
3187	18,11	13,24	38,7	3591	35000	18500
3404	19,33	13,24	36,2	3591	35000	18500
3522	22,24	11,91	31,5	3722	35000	18500
3077	25,26	9,16	27,7	3992	35000	18500
3451	28,33	9,16	24,7	3992	35000	18500
3904	32,05	9,16	21,8	3992	35000	18500
4168	34,22	9,16	20,4	3992	35000	18500
4708	39,38	8,99	17,8	4009	35000	18500

IS143

Mn ₂ [Nm]	i	Pn ₁ [kW]	n ₂ [rpm]	Fr1 [N]	Fr2 D [N]	Fr2 C-L [N]
4264	45,77	7,16	15,3	4200	35000	18500
4749	50,97	7,16	13,7	4200	35000	18500
5030	57,17	6,76	12,2	4200	35000	18500
5073	64,68	6,03	10,8	4200	35000	18500
5181	69,06	5,76	10,1	4200	35000	18500
4498	79,45	4,35	8,8	4200	35000	18500
4717	98,81	3,67	7,1	4200	35000	18500
5029	110,05	3,51	6,4	4200	35000	18500
5052	123,44	3,14	5,7	4200	35000	18500
5143	139,64	2,83	5,0	4200	35000	18500
5085	149,10	2,62	4,7	4200	35000	18500
4039	157,49	1,97	4,4	4200	35000	18500
4961	171,55	2,22	4,1	4200	35000	18500
4499	175,41	1,97	4,0	4200	35000	18500
5046	196,74	1,97	3,6	4200	35000	18500
5010	222,57	1,73	3,1	4200	35000	18500
5187	237,63	1,68	3,0	4200	35000	18500
5091	273,41	1,43	2,6	4200	35000	18500

IS152

Mn ₂ [Nm]	i	Pn ₁ [kW]	n ₂ [rpm]	Fr1 [N]	Fr2 D [N]	Fr2 C-L [N]
2734	4,06	50,64	172,3	2623	34097	19400
3051	4,53	50,62	154,4	2624	34289	19400

IS152

Mn ₂ [Nm]	i	Pn ₁ [kW]	n ₂ [rpm]	Fr1 [N]	Fr2 D [N]	Fr2 C-L [N]
3096	5,20	44,76	134,5	2974	36364	19400
3126	5,71	41,17	122,6	3188	37829	19400
3267	6,52	37,68	107,3	3396	39518	19400
3463	7,28	35,78	96,2	3510	40000	19400
3752	8,36	33,77	83,8	3630	40000	19400
3985	9,17	32,68	76,3	3694	40000	19400
4443	10,42	32,08	67,2	3730	40000	19400
3512	12,46	21,20	56,2	4380	40000	19400
3918	13,91	21,19	50,3	4380	40000	19400
4499	15,97	21,19	43,8	4380	40000	19400
4939	17,53	21,20	39,9	4380	40000	19400
5610	19,91	21,20	35,2	4380	40000	19400
6450	22,88	21,20	30,6	4379	40000	19400
6470	27,11	17,96	25,8	4573	40000	19400
7102	29,75	17,96	23,5	4573	40000	19400
8067	33,79	17,96	20,7	4573	40000	19400
8170	38,84	15,82	18,0	4700	40000	19400

IS153

Mn ₂ [Nm]	i	Pn ₁ [kW]	n ₂ [rpm]	Fr1 [N]	Fr2 D [N]	Fr2 C-L [N]
6674	40,10	12,79	17,5	4897	40000	19400
7448	44,76	12,78	15,6	4898	40000	19400
8357	51,38	12,50	13,6	4914	40000	19400
8770	56,39	11,95	12,4	4946	40000	19400
9345	64,05	11,21	10,9	4990	40000	19400
8266	73,63	8,62	9,5	5141	40000	19400
7550	87,16	6,65	8,0	5200	40000	19400
8426	97,27	6,65	7,2	5200	40000	19400
9673	111,67	6,65	6,3	5200	40000	19400
10132	122,57	6,35	5,7	5200	40000	19400
9713	139,21	5,36	5,0	5200	40000	19400
7574	154,02	3,78	4,5	5200	40000	19400
8590	160,02	4,12	4,4	5200	40000	19400
8695	176,81	3,78	4,0	5200	40000	19400
9543	194,06	3,78	3,6	5200	40000	19400
9938	220,42	3,46	3,2	5200	40000	19400
8796	253,36	2,67	2,8	5200	40000	19400

IS052

Mn ₂ [Nm]	i	Pn ₁ [kW]	n ₂ [rpm]	Fr1 [N]	Fr2 D [N]	Fr2 C-L [N]
183	8,63	1,13	58,0	666	5067	5067
204	11,14	0,98	44,9	766	5482	5482
215	12,00	0,96	41,7	780	5585	5585
226	13,66	0,88	36,6	829	5820	5820
258	15,27	0,90	32,7	816	5901	5901
258	16,29	0,85	30,7	853	6000	6000
258	18,63	0,74	26,8	922	6000	6000
258	19,73	0,70	25,4	949	6000	6000
280	21,04	0,71	23,8	942	6000	6000
280	21,53	0,69	23,2	953	6000	6000
280	24,07	0,62	20,8	1000	6000	6000
312	25,20	0,66	19,8	974	6000	6000
312	25,79	0,65	19,4	984	6000	6000
312	27,81	0,60	18,0	1015	6000	6000
312	30,00	0,56	16,7	1043	6000	6000
323	32,55	0,53	15,4	1060	6000	6000
323	33,00	0,52	15,2	1065	6000	6000
323	34,09	0,51	14,7	1076	6000	6000
355	36,55	0,52	13,7	1067	6000	6000
355	38,75	0,49	12,9	1086	6000	6000
376	39,90	0,50	12,5	1077	6000	6000
376	42,63	0,47	11,7	1098	6000	6000
376	46,00	0,44	10,9	1121	6000	6000
376	47,20	0,43	10,6	1128	6000	6000
376	52,25	0,39	9,6	1155	6000	6000
376	57,86	0,35	8,6	1179	6000	6000
376	59,42	0,34	8,4	1185	6000	6000
376	72,83	0,28	6,9	1226	6000	6000

IS053

Mn ₂ [Nm]	i	Pn ₁ [kW]	n ₂ [rpm]	Fr1 [N]	Fr2 D [N]	Fr2 C-L [N]
376	36,50	0,56	13,7	1046	6000	6000
376	47,14	0,44	10,6	1127	6000	6000
376	57,79	0,36	8,7	1179	6000	6000
376	63,74	0,32	7,8	1200	6000	6000
376	74,20	0,28	6,7	1229	6000	6000
376	78,14	0,26	6,4	1238	6000	6000
376	95,84	0,21	5,2	1269	6000	6000
376	117,48	0,17	4,3	1294	6000	6000
376	137,45	0,15	3,6	1311	6000	6000
376	177,55	0,12	2,8	1332	6000	6000

IS053

Mn ₂ [Nm]	i	Pn ₁ [kW]	n ₂ [rpm]	Fr1 [N]	Fr2 D [N]	Fr2 C-L [N]
376	198,45	0,10	2,5	1340	6000	6000
376	217,64	0,09	2,3	1346	6000	6000
376	256,33	0,08	1,9	1355	6000	6000
376	314,21	0,07	1,6	1365	6000	6000

IS062

Mn ₂ [Nm]	i	Pn ₁ [kW]	n ₂ [rpm]	Fr1 [N]	Fr2 D [N]	Fr2 C-L [N]
355	8,00	2,37	62,5	270	8029	3212
355	8,92	2,13	56,0	388	8406	3362
387	9,55	2,17	52,4	368	8442	3377
387	10,65	1,94	47,0	475	8841	3536
419	11,71	1,91	42,7	490	8997	3599
452	13,06	1,85	38,3	521	9220	3688
452	13,36	1,81	37,4	541	9310	3724
484	15,94	1,62	31,4	630	9837	3935
484	16,16	1,60	30,9	640	9897	3959
484	19,29	1,34	25,9	765	10000	4000
495	19,55	1,35	25,6	759	10000	4000
505	23,18	1,17	21,6	849	10000	4000
505	23,75	1,14	21,1	863	10000	4000
516	25,14	1,10	19,9	882	10000	4000
516	27,66	1,00	18,1	930	10000	4000
538	30,00	0,96	16,7	949	10000	4000
581	33,93	0,91	14,7	970	10000	4000
645	36,57	0,94	13,7	956	10000	4000
645	39,38	0,88	12,7	988	10000	4000
645	43,64	0,79	11,5	1029	10000	4000
645	46,10	0,75	10,8	1050	10000	4000
645	48,30	0,71	10,3	1066	10000	4000
645	53,53	0,64	9,3	1100	10000	4000
645	55,00	0,63	9,1	1108	10000	4000
645	67,47	0,51	7,4	1163	10000	4000

IS063

Mn ₂ [Nm]	i	Pn ₁ [kW]	n ₂ [rpm]	Fr1 [N]	Fr2 D [N]	Fr2 C-L [N]
645	33,57	1,05	14,9	916	10000	4000
645	37,77	0,93	13,2	970	10000	4000
645	40,05	0,88	12,5	995	10000	4000
645	49,13	0,72	10,2	1072	10000	4000

IS063

Mn ₂ [Nm]	i	Pn ₁ [kW]	n ₂ [rpm]	Fr1 [N]	Fr2 D [N]	Fr2 C-L [N]
645	55,29	0,64	9,0	1109	10000	4000
645	58,72	0,60	8,5	1127	10000	4000
645	65,85	0,53	7,6	1157	10000	4000
645	68,25	0,52	7,3	1166	10000	4000
645	73,63	0,48	6,8	1184	10000	4000
645	81,43	0,43	6,1	1206	10000	4000
645	99,89	0,35	5,0	1243	10000	4000
645	126,43	0,28	4,0	1278	10000	4000
645	150,85	0,23	3,3	1299	10000	4000
645	182,53	0,19	2,7	1318	10000	4000
645	185,05	0,19	2,7	1319	10000	4000
645	217,79	0,16	2,3	1333	10000	4000
645	267,16	0,13	1,9	1347	10000	4000

IS082

Mn ₂ [Nm]	i	Pn ₁ [kW]	n ₂ [rpm]	Fr1 [N]	Fr2 D [N]	Fr2 C-L [N]
591	7,34	4,31	68,1	1132	17494	4998
645	8,06	4,28	62,0	1145	17930	5123
699	9,94	3,76	50,3	1369	18000	5483
753	11,61	3,47	43,1	1494	18000	5754
806	12,75	3,38	39,2	1531	18000	5907
817	14,04	3,11	35,6	1647	18000	6113
828	15,43	2,87	32,4	1752	18000	6319
828	15,73	2,81	31,8	1775	18000	6364
828	17,29	2,56	28,9	1885	18000	6592
828	19,03	2,33	26,3	1985	18000	6828
828	20,14	2,20	24,8	2041	18000	6972
860	22,13	2,08	22,6	2092	18000	7186
860	24,00	1,92	20,8	2162	18000	7200
860	26,05	1,77	19,2	2227	18000	7200
968	27,29	1,90	18,3	2171	18000	7200
968	28,67	1,80	17,4	2210	18000	7200
968	29,60	1,75	16,9	2234	18000	7200
1075	31,78	1,81	15,7	2208	18000	7200
1075	34,91	1,65	14,3	2278	18000	7200
1075	35,50	1,62	14,1	2290	18000	7200
1075	40,05	1,44	12,5	2369	18000	7200
1075	43,05	1,34	11,6	2412	18000	7200
1075	50,25	1,14	9,9	2494	18000	7200
1075	54,27	1,06	9,2	2531	18000	7200
1075	61,98	0,93	8,1	2588	18000	7200

IS083

Mn ₂ [Nm]	i	Pn ₁ [kW]	n ₂ [rpm]	Fr1 [N]	Fr2 D [N]	Fr2 C-L [N]
1075	67,52	0,87	7,4	2620	18000	7200
1075	74,18	0,79	6,7	2653	18000	7200
1075	81,71	0,72	6,1	2684	18000	7200
1075	91,49	0,64	5,5	2717	18000	7200
1075	100,62	0,58	5,0	2741	18000	7200
1075	117,17	0,50	4,3	2776	18000	7200
1075	128,73	0,46	3,9	2795	18000	7200
1075	136,34	0,43	3,7	2806	18000	7200
1075	158,76	0,37	3,1	2831	18000	7200
1075	184,88	0,32	2,7	2853	18000	7200
1075	203,11	0,29	2,5	2865	18000	7200
1075	205,34	0,29	2,4	2867	18000	7200
1075	226,04	0,26	2,2	2878	18000	7200
1075	250,50	0,23	2,0	2888	18000	7200
1075	266,13	0,22	1,9	2894	18000	7200
1075	292,36	0,20	1,7	2902	18000	7200
1075	315,73	0,19	1,6	2909	18000	7200
1075	360,58	0,16	1,4	2918	18000	7200

IS102

Mn ₂ [Nm]	i	Pn ₁ [kW]	n ₂ [rpm]	Fr1 [N]	Fr2 D [N]	Fr2 C-L [N]
914	8,06	6,06	62,0	471	22000	6293
968	8,85	5,85	56,5	560	22000	6470
1021	10,88	5,02	45,9	905	22000	6939
1075	12,75	4,51	39,2	1116	22000	7312
1290	13,99	4,93	35,7	941	22000	7405
1344	15,43	4,66	32,4	1054	22000	7639
1398	17,21	4,34	29,1	1185	22000	7917
1505	19,00	4,24	26,3	1229	22000	8134
1505	20,83	3,86	24,0	1384	22000	8419
1505	22,13	3,64	22,6	1478	22000	8611
1613	24,28	3,55	20,6	1513	22000	8833
1613	26,33	3,27	19,0	1629	22000	9000
1613	29,87	2,89	16,7	1790	22000	9000
1613	32,40	2,66	15,4	1883	22000	9000
1505	34,91	2,31	14,3	2031	22000	9000
1613	38,30	2,25	13,1	2054	22000	9000
1505	42,53	1,89	11,8	2203	22000	9000
1398	44,00	1,70	11,4	2283	22000	9000
1720	47,13	1,95	10,6	2178	22000	9000
1505	50,25	1,60	9,9	2324	22000	9000

IS102

Mn ₂ [Nm]	i	Pn ₁ [kW]	n ₂ [rpm]	Fr1 [N]	Fr2 D [N]	Fr2 C-L [N]
1398	55,14	1,36	9,1	2426	22000	9000
1720	59,40	1,55	8,4	2346	22000	9000
1720	67,84	1,36	7,4	2426	22000	9000

IS103

Mn ₂ [Nm]	i	Pn ₁ [kW]	n ₂ [rpm]	Fr1 [N]	Fr2 D [N]	Fr2 C-L [N]
1720	74,18	1,27	6,7	2474	22000	9000
1720	81,39	1,15	6,1	2520	22000	9000
1720	89,77	1,05	5,6	2563	22000	9000
1720	100,15	0,94	5,0	2607	22000	9000
1720	110,55	0,85	4,5	2643	22000	9000
1720	121,29	0,77	4,1	2674	22000	9000
1720	128,73	0,73	3,9	2692	22000	9000
1720	141,24	0,66	3,5	2718	22000	9000
1720	173,78	0,54	2,9	2769	22000	9000
1720	188,51	0,50	2,6	2786	22000	9000
1720	203,11	0,46	2,5	2801	22000	9000
1720	222,85	0,42	2,2	2817	22000	9000
1720	224,76	0,42	2,2	2819	22000	9000
1720	274,20	0,34	1,8	2850	22000	9000
1720	280,89	0,33	1,8	2853	22000	9000
1720	292,36	0,32	1,7	2858	22000	9000
1720	320,79	0,29	1,6	2870	22000	9000
1720	345,60	0,27	1,4	2878	22000	9000
1720	394,69	0,24	1,3	2892	22000	9000

IS122

Mn ₂ [Nm]	i	Pn ₁ [kW]	n ₂ [rpm]	Fr1 [N]	Fr2 D [N]	Fr2 C-L [N]
1613	8,48	10,16	59,0	2875	29386	8396
1828	9,30	10,51	53,8	2838	29662	8475
1828	10,24	9,54	48,8	2941	30000	8813
2043	11,42	9,57	43,8	2939	30000	8975
2365	12,63	10,02	39,6	2891	30000	9004
2580	13,84	9,97	36,1	2896	30000	9127
2795	16,99	8,79	29,4	3022	30000	9729
3010	21,25	7,57	23,5	3153	30000	10473
3010	22,37	7,20	22,4	3193	30000	10707
3118	23,29	7,16	21,5	3197	30000	10779
3225	26,15	6,59	19,1	3258	30000	11200

IS122

Mn ₂ [Nm]	i	Pn ₁ [kW]	n ₂ [rpm]	Fr1 [N]	Fr2 D [N]	Fr2 C-L [N]
3225	28,60	6,03	17,5	3318	30000	11200
3225	30,51	5,65	16,4	3359	30000	11200
3225	32,76	5,26	15,3	3401	30000	11200
3225	33,44	5,16	14,9	3412	30000	11200
3225	35,20	4,90	14,2	3440	30000	11200
3225	41,07	4,20	12,2	3515	30000	11200
3225	43,60	3,96	11,5	3541	30000	11200
2580	44,63	3,09	11,2	3634	30000	11200
2580	49,04	2,81	10,2	3664	30000	11200
2795	53,75	2,78	9,3	3667	30000	11200
3225	66,00	2,61	7,6	3685	30000	11200

IS123

Mn ₂ [Nm]	i	Pn ₁ [kW]	n ₂ [rpm]	Fr1 [N]	Fr2 D [N]	Fr2 C-L [N]
2903	64,84	2,44	7,7	3709	30000	11200
2903	71,07	2,23	7,0	3731	30000	11200
3225	78,46	2,24	6,4	3730	30000	11200
3225	87,27	2,02	5,7	3753	30000	11200
3225	105,91	1,66	4,7	3791	30000	11200
3225	112,52	1,57	4,4	3801	30000	11200
3225	123,33	1,43	4,0	3815	30000	11200
3225	130,04	1,35	3,8	3823	30000	11200
3225	133,78	1,32	3,7	3827	30000	11200
3225	151,43	1,16	3,3	3843	30000	11200
3225	177,53	0,99	2,8	3861	30000	11200
3225	194,59	0,91	2,6	3870	30000	11200
3225	215,60	0,82	2,3	3880	30000	11200
3225	238,93	0,74	2,1	3888	30000	11200

IS142

Mn ₂ [Nm]	i	Pn ₁ [kW]	n ₂ [rpm]	Fr1 [N]	Fr2 D [N]	Fr2 C-L [N]
1493	4,12	19,39	121,4	2211	32760	18500
1664	4,59	19,40	109,0	2210	33023	18500
1868	5,14	19,41	97,2	2208	33200	18500
2111	5,82	19,40	85,9	2210	33271	18500
2257	6,21	19,42	80,5	2207	33215	18500
2059	7,32	15,05	68,3	2812	35000	18500
2310	8,21	15,05	60,9	2812	35000	18500
2614	9,29	15,05	53,9	2811	35000	18500

IS142

Mn ₂ [Nm]	i	Pn ₁ [kW]	n ₂ [rpm]	Fr1 [N]	Fr2 D [N]	Fr2 C-L [N]
2791	9,91	15,06	50,4	2811	35000	18500
3027	11,41	14,19	43,8	2930	35000	18500
2817	12,81	11,75	39,0	3267	35000	18500
2623	14,27	9,83	35,0	3534	35000	18500
2851	16,01	9,52	31,2	3576	35000	18500
3225	18,11	9,52	27,6	3576	35000	18500
3444	19,33	9,52	25,9	3576	35000	18500
3564	22,24	8,57	22,5	3708	35000	18500
3113	25,26	6,59	19,8	3981	35000	18500
3491	28,33	6,59	17,6	3982	35000	18500
3950	32,05	6,59	15,6	3982	35000	18500
4217	34,22	6,59	14,6	3982	35000	18500
4763	39,38	6,47	12,7	3998	35000	18500

IS143

Mn ₂ [Nm]	i	Pn ₁ [kW]	n ₂ [rpm]	Fr1 [N]	Fr2 D [N]	Fr2 C-L [N]
4314	45,77	5,15	10,9	4196	35000	18500
4805	50,97	5,15	9,8	4196	35000	18500
5090	57,17	4,86	8,8	4200	35000	18500
5133	64,68	4,33	7,7	4200	35000	18500
5242	69,06	4,15	7,2	4200	35000	18500
4551	79,45	3,13	6,3	4200	35000	18500
4773	98,81	2,64	5,1	4200	35000	18500
5089	110,05	2,52	4,5	4200	35000	18500
5111	123,44	2,26	4,0	4200	35000	18500
5204	139,64	2,03	3,6	4200	35000	18500
5145	149,10	1,88	3,4	4200	35000	18500
4086	157,49	1,42	3,2	4200	35000	18500
5020	171,55	1,60	2,9	4200	35000	18500
4551	175,41	1,42	2,9	4200	35000	18500
5105	196,74	1,42	2,5	4200	35000	18500
5069	222,57	1,24	2,2	4200	35000	18500
5248	237,63	1,21	2,1	4200	35000	18500
5151	273,41	1,03	1,8	4200	35000	18500

IS152

Mn ₂ [Nm]	i	Pn ₁ [kW]	n ₂ [rpm]	Fr1 [N]	Fr2 D [N]	Fr2 C-L [N]
2766	4,06	36,42	123,1	2588	39530	19400
3086	4,53	36,41	110,3	2588	39910	19400

IS152

Mn ₂ [Nm]	i	Pn ₁ [kW]	n ₂ [rpm]	Fr1 [N]	Fr2 D [N]	Fr2 C-L [N]
3133	5,20	32,19	96,1	2943	40000	19400
3163	5,71	29,61	87,5	3159	40000	19400
3306	6,52	27,10	76,7	3370	40000	19400
3503	7,28	25,73	68,7	3485	40000	19400
3796	8,36	24,28	59,8	3606	40000	19400
4032	9,17	23,50	54,5	3671	40000	19400
4496	10,42	23,07	48,0	3708	40000	19400
3554	12,46	15,25	40,1	4365	40000	19400
3964	13,91	15,24	36,0	4365	40000	19400
4552	15,97	15,24	31,3	4365	40000	19400
4997	17,53	15,24	28,5	4365	40000	19400
5676	19,91	15,24	25,1	4365	40000	19400
6526	22,88	15,25	21,9	4364	40000	19400
6546	27,11	12,91	18,4	4561	40000	19400
7186	29,75	12,91	16,8	4560	40000	19400
8162	33,79	12,91	14,8	4560	40000	19400
8266	38,84	11,38	12,9	4689	40000	19400

IS153

Mn ₂ [Nm]	i	Pn ₁ [kW]	n ₂ [rpm]	Fr1 [N]	Fr2 D [N]	Fr2 C-L [N]
6752	40,10	9,19	12,5	4889	40000	19400
7536	44,76	9,19	11,2	4889	40000	19400
8455	51,38	8,99	9,7	4906	40000	19400
8873	56,39	8,59	8,9	4938	40000	19400
9455	64,05	8,06	7,8	4982	40000	19400
8363	73,63	6,20	6,8	5135	40000	19400
7638	87,16	4,79	5,7	5200	40000	19400
8525	97,27	4,79	5,1	5200	40000	19400
9787	111,67	4,79	4,5	5200	40000	19400
10251	122,57	4,57	4,1	5200	40000	19400
9828	139,21	3,85	3,6	5200	40000	19400
7663	154,02	2,72	3,2	5200	40000	19400
8691	160,02	2,97	3,1	5200	40000	19400
8798	176,81	2,72	2,8	5200	40000	19400
9656	194,06	2,72	2,6	5200	40000	19400
10055	220,42	2,49	2,3	5200	40000	19400
8900	253,36	1,92	2,0	5200	40000	19400

6.1 TXF - PERFORMANCE

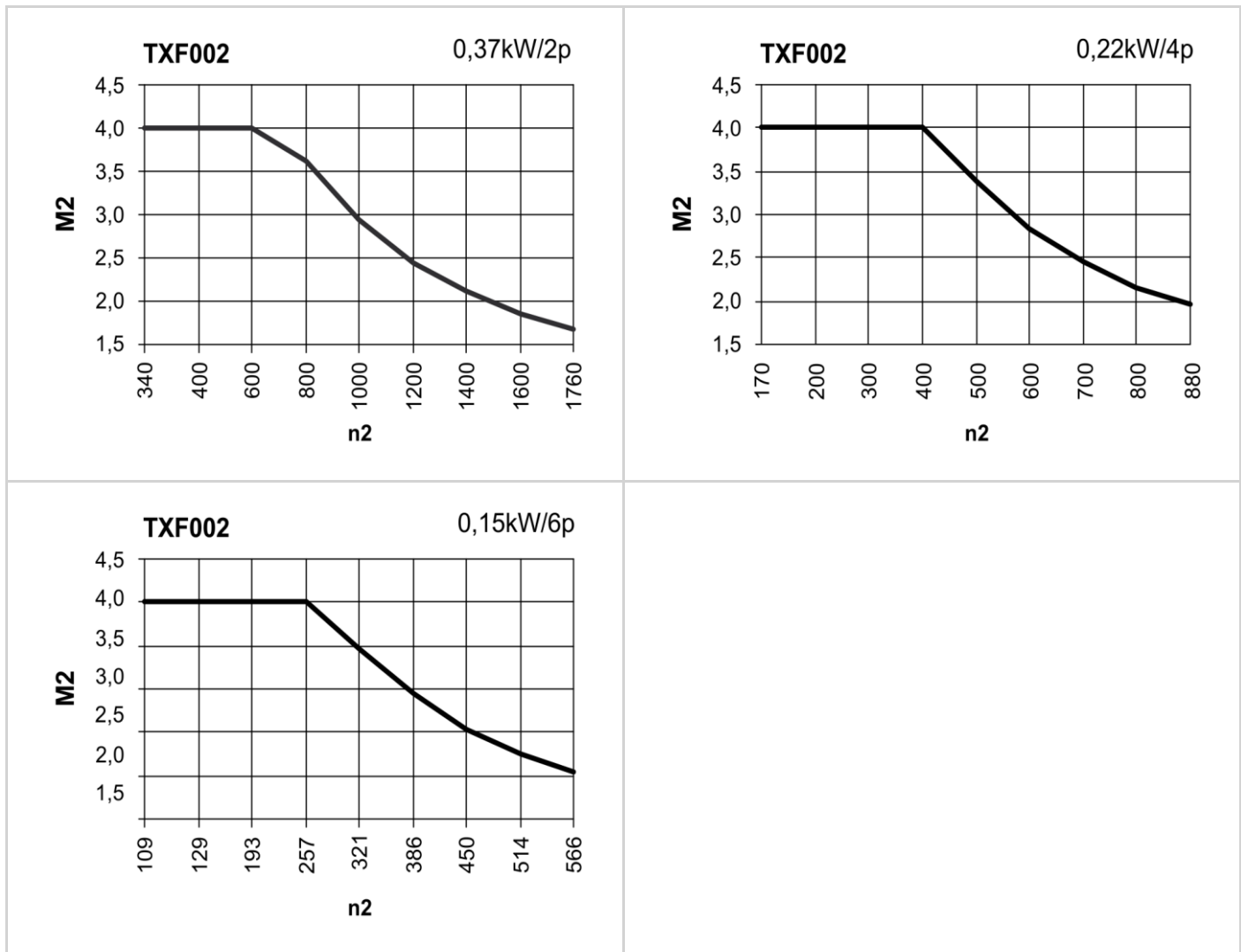

6.1 TXF - PERFORMANCE

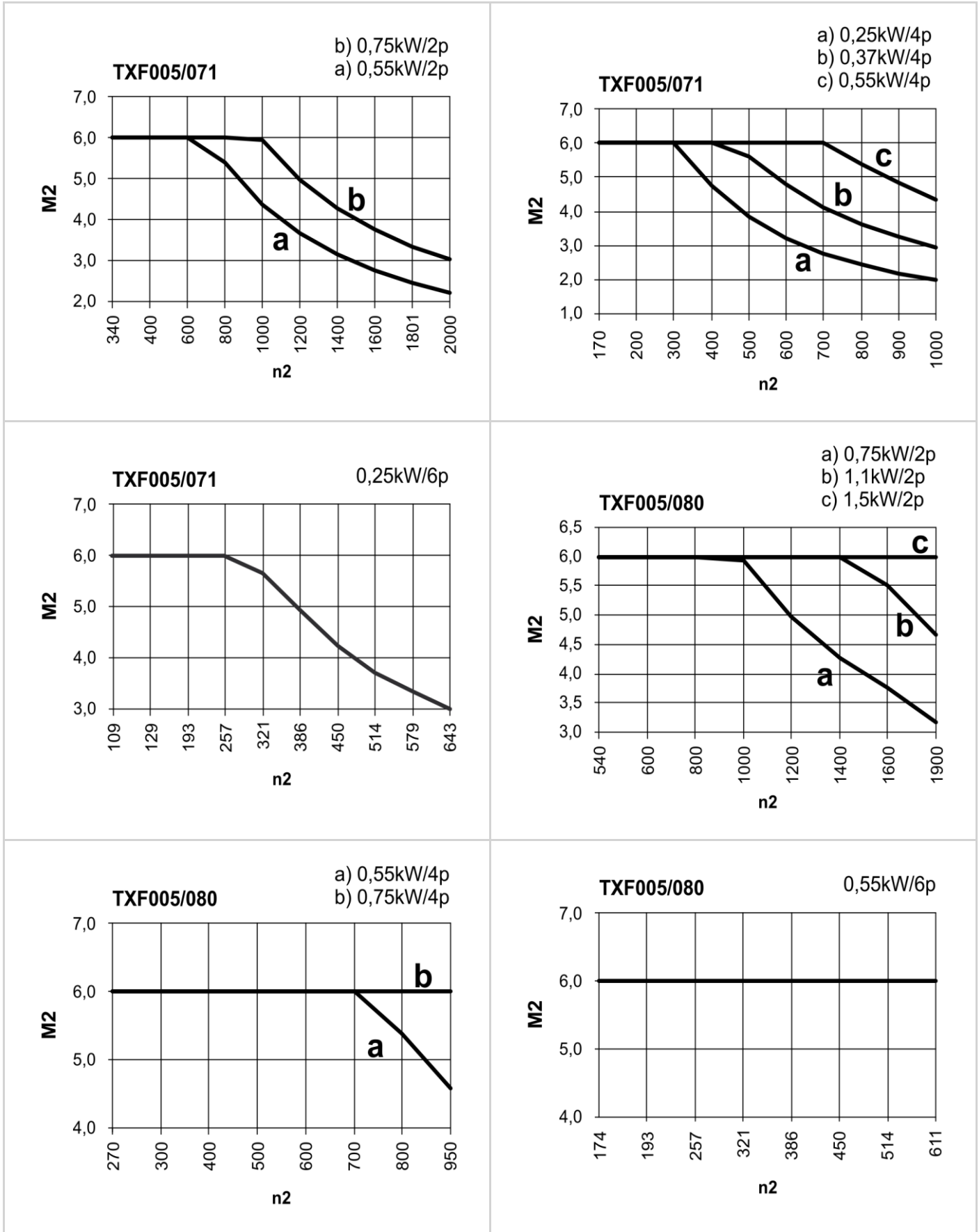

6.1 TXF - PERFORMANCE

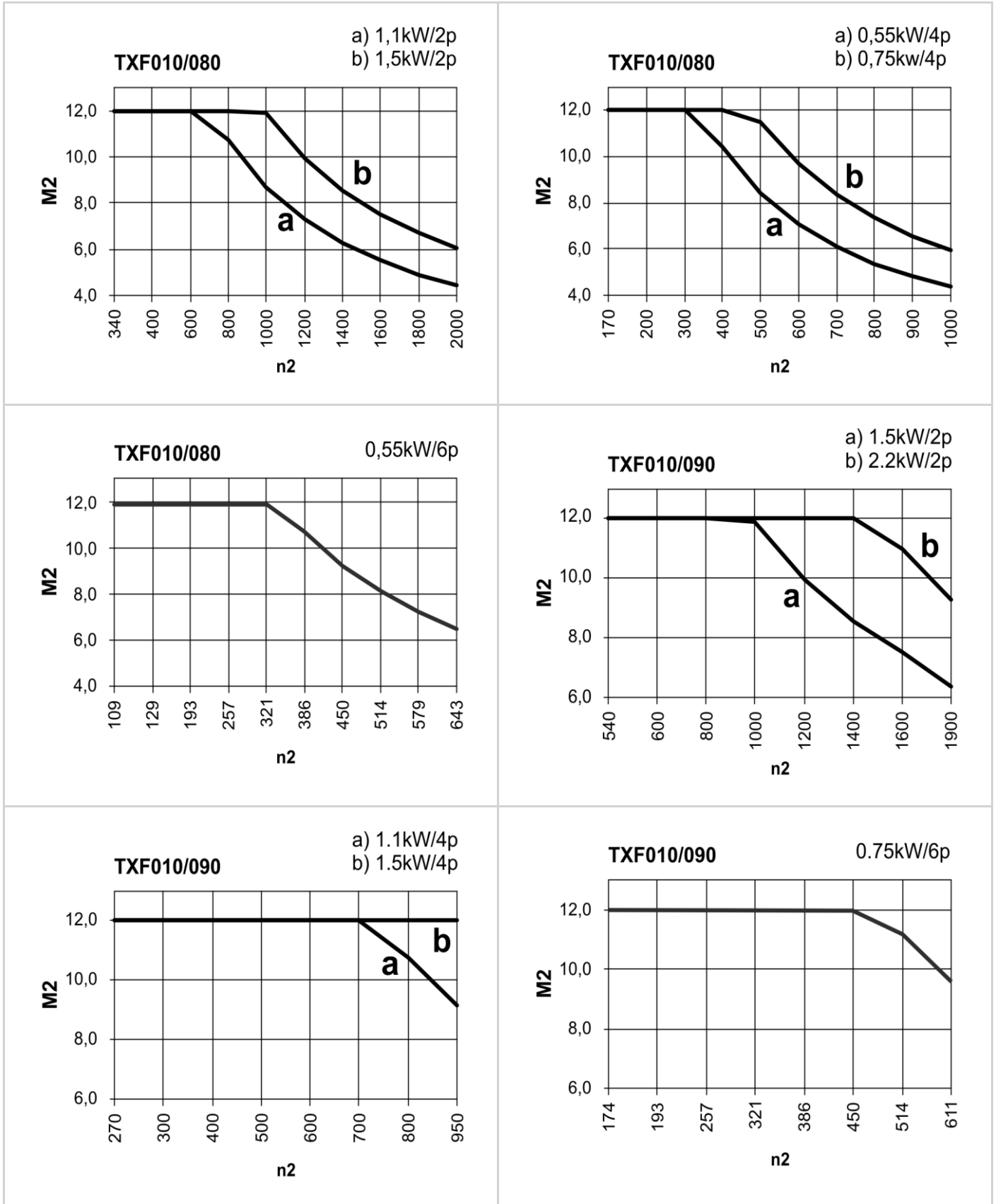

All supplies effected by MOTOVARIO are governed exclusively by the general terms of sale that you can find on our website:

<http://www.motovario.com/eng/corporate/sales-conditions>

