



BEVEL GEARS

STANDARD EXECUTION	page 5
SPECIALE CH EXECUTION	
GLEASON SYSTEM	9
DIN 3971 EXECUTION	19
SPIRALS	25
SPECIAL PRODUCTIONS	
ON REQUEST	27



BEVEL GEARS

BEVEL GEARS

BEVEL GEAR WITH STRAIGHT TEETH
SPECIAL CH EXECUTION
GLEASON SYSTEM



SPIRALS BEVEL GEARS



BEVEL GEAR WITH STRAIGHT TEETH
STANDARD EXECUTION



BEVEL GEARS
FOR TRANSMISSIONS
BETWEEN ORTHOGONAL
AXES DIN 3971



The range of bevel gear showed in the catalogue is a selection structured according to transmission module and ratio, which is designed to meet the needs of general plant engineering and general mechanics to transmit motion among concurrent axes.

As such the range does not claim to guarantee particularly heavyduty performance or to cater for ratio ranges that extend to cover every need.

The external configuration of the bevel gear complies with the sizing criteria as established by the

DIN 3971 Standards,

while the tooth geometry, corrected by displacing the profiles and by varying the taper, is a specific solution exclusive to CHIARAVALLI GROUP SpA.

This solution, provides special advantages since:

- the coupling conditions between the pinion and the ring gear are improved;
- a smoother motion transmission is assured;
- tooth resistance is increased;
- the undercut effect on the pinion is avoided, even in the case of high transmission ratios and pinions with a limited number of teeth.

Since these refer to a selection of gears intended to be used in a broad range of applications, CHIARAVALLI GROUP SpA, continuing a tradition that has now become firmly established, has defined a standardised tolerance category for the processing of the Company's range of bevel gear, which means that there is a controlled gearing gap between the wheels.

The requirements detailed in the

DIN 3967 Standards

adapted to the virtual teeth profile of the bevel gear and the recommendations of the

DIN 3964 Standards

to calculate the corresponding axial displacements for the assembly distances have been used for this purpose.

We are therefore in a position to provide the end user precise information regarding the tolerances to be adopted to define shaving adjustments to a given clearance, in accordance with the values detailed in the dimensional tables.

All the bevel gears manufactured by CHIARAVALLI GROUP SpA will be produced in accordance with the profile envelope procedure on modern gear cutting machines, which enables CHIARAVALLI GROUP SpA to ensure a satisfactory quality level thanks to the systematic checking of processing tolerances.

For this technological sector too, the equipment and the range of machines available to CHIARAVALLI GROUP SpA enables the Company to produce bevel gears based on a drawing and in accordance with the Customer's specifications.





BEVEL GEARS WITH STRAIGHT TEETH

BEVEL GEARS WITH STRAIGHT TEETH





BEVEL GEAR WITH STRAIGHT TEETH norm DIN 3967

5

RATIO 1:1

Pressure angle: 20°
with normal axes in compliance to
UNI 6588

Teeth according to DIN 3967

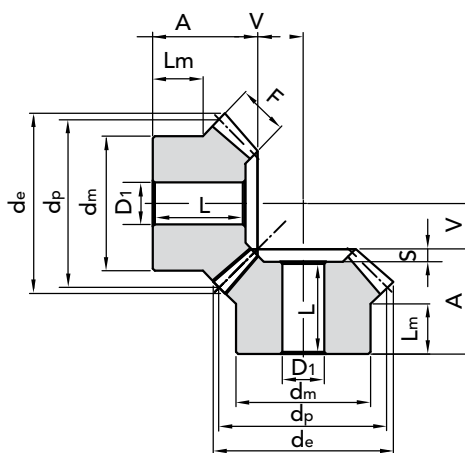

M	Z	PART NUMBER	d_p	d_e	F	A	d_m	D_1	L	V	S	L_m	Kg
1.5	16	35151116	24,0	26,12	6	18,9	20,3	8	-	7,10	-	12	0,03
	20	32151120	30,0	32,12	10	20	22	10	18	7,40	2	8,5	0,05
	25	32151125	37,5	39,62	10	23	28	10	21	11,09	2	12	0,10
	30	32151130	45,0	47,12	12	25	30	12	22,5	13,35	2,5	12	0,15
2	16	35201116	32,0	34,83	8	23,5	25,3	8	-	9,50	-	14	0,06
	20	32201120	40,0	42,83	12	25	32	10	22	10,78	3	11,7	0,14
	25	32201125	50,0	52,82	14	28	40	12	25	14,28	3	12,3	0,25
	30	32201130	60,0	62,83	16	30	50	12	27	17,78	3	12,8	0,41
2.5	16	35251116	40,0	43,53	10	28,1	30,3	12	-	11,90	-	15	0,13
	20	32251120	50,0	53,53	12	30,5	40	12	27	15,43	3,5	16	0,27
	25	32251125	62,5	66	15	33,5	50	15	30	19,48	3,5	16	0,47
	30	32251130	75,0	78,53	18	35,5	55	15	32	23,63	3,5	16	0,69
3	16	35301116	48,0	52,25	12	31,7	40,3	12	-	14,30	-	18	0,24
	20	32301120	60,0	64,24	18	35	45	15	31	16,00	4	13,6	0,41
	25	32301125	75,0	79,24	20	38	55	15	34	22,00	4	16	0,72
	30	32301130	90,0	94,24	22	40	60	20	36	28,00	4	17	0,99
3.5	16	35351116	56,0	60,95	14	36,4	45,3	16	-	16,60	-	20	0,38
	20	32351120	70,0	74,95	22	40,5	55	15	36	18,13	4,5	16,1	0,68
	25	32351125	87,5	92,45	26	43,5	65	20	39	23,97	4,5	18	1,10
	30	32351130	105,0	109,95	30	48	70	20	43,5	30,02	4,5	19	1,61
4	16	35401116	64,0	69,65	15	44,3	50,3	16	-	19,70	-	25	0,52
	20	32401120	80,0	85,65	25	43	60	18	38	20,74	5	18	0,90
	25	32401125	100,0	105,65	28	45	70	20	40	28,50	5	18	1,45
	30	32401130	120,0	125,65	32	48	80	20	43	35,67	5	16	2,66
4.5	16	35451116	72,0	78,38	17,5	46,3	55,3	20	-	21,70	-	25	0,73
	20	32451120	90,0	96,38	28	48	65	20	42	23,41	6	18	1,25
	25	32451125	112,5	118,8	32	50	75	20	44	31,76	6	18	2,04
	30	32451130	135,0	141,38	35	53	90	20	47	40,82	6	17	3,24
5	16	35501116	80,0	87,07	18	48,9	60,3	20	-	25,10	-	25	0,94
	20	32501120	100,0	107,07	30	50,5	70	20	44	26,86	6,5	18,5	1,61
	25	32501125	125,0	132,07	34	53,5	90	20	47	36,36	6,5	18	2,94
	30	32501130	150,0	157,07	38	56,5	110	20	50	45,97	6,5	18	4,46

MATERIAL C 45 UNI 7847

CAD drawings available on our site
www.chiaravalli.com

Quantity, availability and prices
on B2B Chiaravalli



BEVEL GEAR WITH STRAIGHT TEETH RATIO 1:1

RATIO 1:2

Pressure angle: 20°
with normal axes in compliance to
UNI 6588

Teeth according to DIN 3967

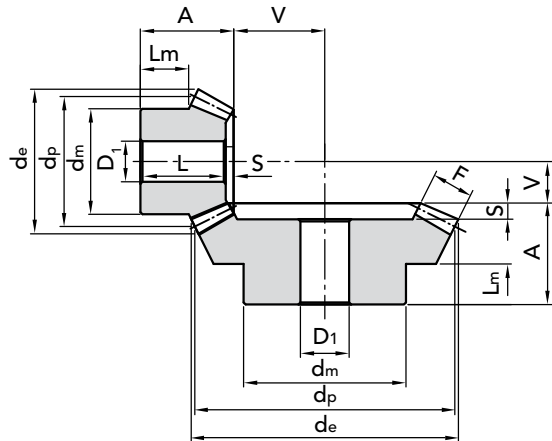

M	Z	PART NUMBER	d_p	d_e	F	A	d_m	D_1	L	V	S	L_m	Kg
1,5	16	32151216	24,0	26,68	8	19,5	21	10	18	16,33	1,5	11,3	0,04
	32	33151232	48,0	49,34	8	20	32	12	17	7,45	3	10	0,14
2	16	32201216	32,0	35,57	10	23	26	10	21	22,41	2	11,9	0,09
	32	33201232	64,0	65,78	10	25	40	12	21	10,21	4	10	0,14
2,5	16	32251216	40,0	44,47	12	27,5	34	12	25	28,38	2,5	14,4	0,16
	32	33251232	80,0	82,23	12	25	50	15	20	12,97	5	10	0,59
3	16	32301216	48,0	53,36	15	28	40	15	25	33,64	3	11,6	0,23
	32	33301232	96,0	98,68	15	30	60	15	24	15,31	6	10	1,05
3,5	16	32351216	56,0	62,26	18	33,5	48	15	30	38,83	3,5	14,4	0,40
	32	33351232	112,0	115,12	18	31	70	20	24	17,77	7	10	1,57
4	16	32401216	64,0	71,15	20	36	50	15	32	44,81	4	13,4	0,49
	32	33401232	128,0	131,57	20	32	80	20	24	20,42	8	10	2,29
4,5	16	32451216	72,0	80,05	22	39,5	60	20	35	51,00	4,5	15,4	0,75
	32	33451232	144,0	148	22	36	90	20	27	23,21	9	10	2,99
5	16	32501216	80,0	88,94	25	50	60	20	45	56,06	5	21,1	1,07
	32	33501232	160,0	164,46	25	38	100	20	28	25,52	10	10	3,95

MATERIAL **C 45 UNI 7847**

CAD drawings available on our site
www.chiaravalli.com

Quantity, availability and prices
on B2B Chiaravalli





BEVEL GEAR WITH STRAIGHT TEETH norm DIN 3967

7

RATIO 1:3

Pressure angle: 20°
with normal axes in compliance to
UNI 6588

Teeth according to DIN 3967

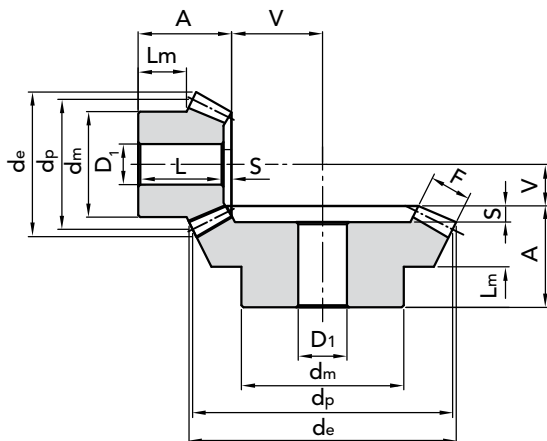

M	Z	PART NUMBER	d_p	d_e	F	A	d_m	D_1	L	V	S	L_m	Kg
1,5	16	32151316	24,0	26,82	12	24	20	10	23	24,32	1	11,7	0,04
	48	33151348	72,0	72,95	12	20	50	12	17	7,27	3	10	0,31
2	16	32201316	32,0	35,8	15	28,5	26	12	27	33,26	1,5	12,4	0,08
	48	33201348	96,0	97,26	15	23	60	15	19	9,90	4	10	0,67
2,5	16	32251316	40,0	44,74	18	32	32	12	30	42,41	1,5	13	0,15
	48	33251348	120,0	121,58	18	26	70	20	21	12,60	5	10	1,22
3	16	32301316	48,0	53,69	18	32	40	15	30	54,25	2	12,1	0,27
	48	33301348	144,0	145,9	18	29	80	20	23	16,20	6	10	2,01
3,5	16	32351316	56,0	62,64	22	38	48	15	35,5	62,29	2,5	15	0,45
	48	33351348	168,0	170,21	22	31	90	20	24	18,48	7	10	3,08
4	16	32401316	64,0	71,59	25	41,5	55	20	38,5	71,23	3	15,2	0,67
	48	33401348	192,0	194,53	25	33	100	20	25	21,20	8	10	4,40
4,5	16	32451316	72,0	80,53	28	53	60	20	50	80,27	3	23,4	1,05
	48	33451348	216,0	218,84	28	49	100	20	40	23,93	9	18	7,23
5	16	32501316	80,0	89,48	35	60	60	20	57	85,61	3	22,5	1,38
	48	33501348	240,0	243,16	35	50	150	20	40	25,45	10	20	8,72

BEVEL GEAR WITH STRAIGHT TEETH RATIO 1:3

6

MATERIAL C 45 UNI 7847

CAD drawings available on our site
www.chiaravalli.com

Quantity, availability and prices
on B2B Chiaravalli





RATIO 1:4

Pressure angle: 20°
with normal axes in compliance to
UNI 6588

Teeth according to DIN 3967

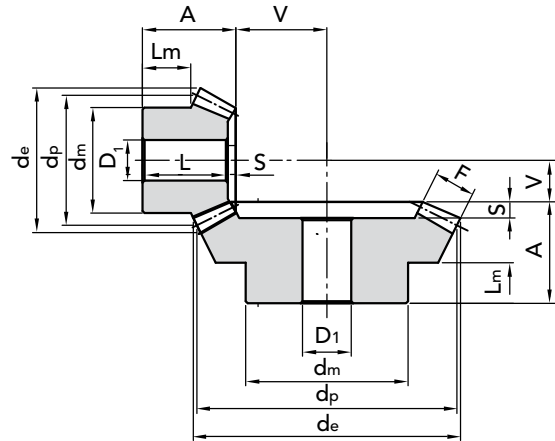

M	Z	PART NUMBER	d_p	d_e	F	A	d_m	D_1	L	V	S	L_m	Kg
1,5	16	32151416	24,0	26,91	12	25	18	10	24	36,09	1	12,2	0,04
	64	33151464	96,0	96,73	12	22	70	15	19	8	3	10	0,75
2	16	32201416	32,0	35,88	15	24	25	12	23	49	1	8,2	0,08
	64	33201464	128,0	128,97	15	24	80	20	20	10,88	4	10	1,35
2,5	16	32251416	40,0	44,85	18	30,5	30	12	29	62,07	1,5	11,7	0,18
	64	33251464	160,0	161,21	18	29	90	20	24	13,74	5	10	2,70
3	16	32301416	48,0	53,82	22	34	40	15	32	74,10	2	11	0,29
	64	33301464	192,0	193,45	22	30	100	20	24	16,41	6	10	4,12
3,5	16	32351416	56,0	62,8	25	45	48	15	43	87,10	2	19,1	0,48
	64	33351464	224,0	225,7	25	50	100	20	43	19,28	7	22	7,53
4	16	32401416	64,0	71,76	30	50	50	20	48	98,17	2	18,5	0,75
	64	33401464	256,0	257,94	30	50	120	20	42	21,76	8	20	10,66
4,5	16	32451416	72,0	80,73	32	53	55	20	50,5	112,08	2,5	19	1,12
	64	33451464	288,0	290,18	32	53	130	20	44	24,83	9	23	13,8
5	16	32501416	80,0	89,7	35	58	60	20	55,5	125,12	2,5	20,6	1,54
	64	33501464	320,0	322,42	35	58	150	20	48	27,73	10	25	15,6

MATERIAL **C 45 UNI 7847**

CAD drawings available on our site
www.chiaravalli.com

Quantity, availability and prices
on B2B Chiaravalli





BEVEL GEAR WITH STRAIGHT TEETH SPECIAL CH EXECUTION GLEASON SYSTEM

RATIO 1:1

Normal axis
Pressure angle: 20°

GLEASON SYSTEM

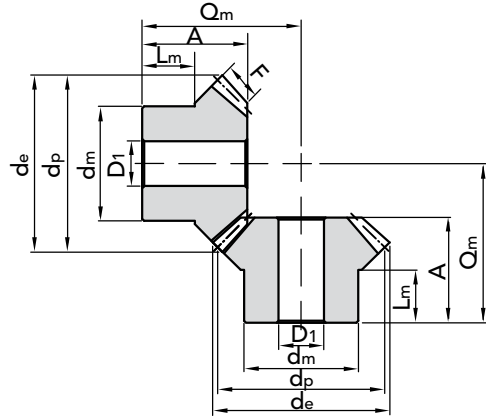

M	Z	PART NUMBER	d _p	d _e	F	A	d _m	D ₁	V	L _m	Kg
1	16	35101116	16	17,4	4	11,2	13,3	4	4,8	6,5	0,02
	19	35101119	19	20,4	4	11,8	15,3	4	6,2	6,5	0,02
	22	35101122	22	23,4	4,7	12,8	16,3	5	7,2	6,5	0,02
	26	35101126	26	27,4	5,5	13,3	20,3	5	8,7	7	0,04
	30	35101130	30	31,4	6,4	16	20,3	5	10	8	0,05
1,5	16	35151116	24	26,1	6	18,9	20,3	8	7,1	12	0,04
	19	35151119	28,5	30,6	7	21,3	20,3	8	8,7	12	0,05
	22	35151122	33	35,1	7,5	22,5	25,3	8	10,5	12	0,09
	26	35151126	39	41,1	8,5	23,2	28,3	8	12,8	12	0,12
	30	35151130	45	47,1	10	27,2	30,3	12	14,8	12	0,17
2	16	35201116	32	34,8	8	23,5	25,3	8	9,5	14	0,08
	19	35201119	38	40,8	9	24,2	25,3	8	11,8	12	0,11
	22	35201122	44	46,8	10	27,9	30,3	12	14,1	14	0,18
	26	35201126	52	54,8	12	31,4	35,3	12	16,6	14	0,28
	30	35201130	60	62,8	13	34,1	40,3	14	19,9	17	0,41
2,5	16	35251116	40	43,5	10	28,1	30,3	12	11,9	15	0,14
	19	35251119	47,5	51	11	27,1	35,3	12	14,9	13	0,21
	22	35251122	55	58,5	12	30,1	45,3	16	17,9	16	0,36
	26	35251126	65	68,5	15	33,2	45,3	16	20,8	16	0,47
	30	35251130	75	78,5	16	39	50,3	16	25	20	0,74
3	16	35301116	48	52,5	12	31,7	40,3	12	14,3	18	0,28
	19	35301119	57	61,2	13	36	40,3	14	18	17	0,39
	22	35301122	66	70,2	15	36,9	50,3	16	21,1	17	0,59
	26	35301126	78	82,2	17	38,4	50,3	16	25,6	18	0,77
	30	35301130	90	94,2	19	43,8	60,3	20	30,2	22	1,19
3,5	16	35351116	56	60,9	14	36,4	45,3	16	16,6	20	0,41
	19	35351119	66,5	71,5	15	37,8	50,3	18	21	19	0,59
	22	35351122	77	81,9	17	39,1	55,3	20	24,9	18	0,84
	26	35351126	91	96	20	43,35	62,3	20	29,7	20	1,17
	30	35351130	105	110	23	47,1	70,3	20	34,9	22	1,69
4	16	35401116	64	69,7	15	44,3	50,3	16	19,7	25	0,66
	19	35401119	76	81,7	18	44,4	55,3	20	23,6	22	0,88
	22	35401122	88	93,7	20	45,9	60,3	20	28,1	22	1,21
	26	35401126	104	109,7	23	48	70,3	20	34	22	1,68
	30	35401130	120	125,7	26	54,2	80,3	20	39,8	25	2,50
4,5	16	35451116	72	78,4	17,5	46,3	55,3	20	21,7	25	0,84
	19	35451119	85,5	91,8	20	49	62,3	20	26,57	25	1,15
	22	35451122	99	105,3	22	50,1	70,3	20	31,9	25	1,72
	26	35451126	117	123	25	54,7	75,3	20	38,6	26	2,22
	30	35451130	135	141,4	29	60	80,3	20	45	28	3,25
5	16	35501116	80	87,1	18	48,9	60,3	20	25,1	25	1,10
	19	35501119	95	102,1	22	52,2	60,3	20	29,8	25	1,50
	22	35501122	110	117,1	24	58,2	80,3	20	35,8	30	2,39
	26	35501126	130	137,1	29	62,7	80,3	20	42,3	30	3,27
	30	35501130	150	157,1	32	68,9	80,3	20	50,1	35	4,13

BEVEL GEAR WITH STRAIGHT TEETH SPECIAL CH EXECUTION RATIO 1:1

MATERIAL **C 45 UNI 7847**



CAD drawings available on our site
www.chiaravalli.com

Quantity, availability and prices
on B2B Chiaravalli

BEVEL GEAR WITH STRAIGHT TEETH SPECIAL CH EXECUTION GLEASON SYSTEM

BEVEL GEAR WITH STRAIGHT TEETH SPECIAL CH EXECUTION RATIO 1:1.5
RATIO 1:1.5

Normal axis

Pressure angle: 20°

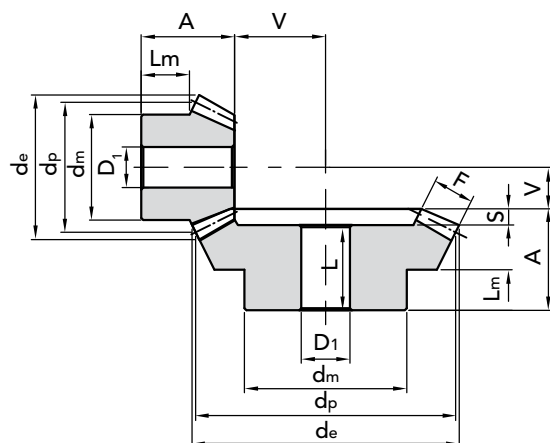
GLEASON SYSTEM

M	Z	PART NUMBER	d_p	d_e	F	A	d_m	D_1	L	V	S	L_m	Kg
1	16	35101516	16	18,1	4,3	12	13,3	4		8		7	0,04
	24	36101524	24	24,8	4,3	14,8	20,3	5	13,3	5,2	1,5	9,3	0,05
1,5	16	35151516	24	27,1	8	20,3	20,3	8		10,7		11,8	0,04
	24	36151524	36	37,2	8	24,9	28,3	8	22,7	7,1	2,2	16	0,04
2	16	35201516	32	36,2	10	25,2	25,3	8		14,8		13,8	0,08
	24	36201524	48	49,7	10	27,2	32,3	8	24,7	9,8	2,5	16	0,32
2,5	16	35251516	40	45,2	13	30,8	32,3	12		18,2		16,4	0,14
	24	36251524	60	62,1	13	34	45,3	14	30,8	12	3,2	20	0,50
3	16	35301516	48	54,3	14,5	32,4	40,3	12		22,6		16,4	0,28
	24	36301524	72	74,5	14,5	36,2	55,3	16	32	14,8	4,2	20	0,96
3,5	16	35351516	56	63,3	18	40,4	45,3	16		25,6		20,4	0,41
	24	36351524	84	86,9	18	44,2	55,3	20	40	16,8	4,2	25	1,30
4	16	35401516	64	72,4	18	46,8	50,3	16		31,2		25,4	0,66
	24	36401524	96	99,3	18	45,5	60,3	20	40	20,5	5,5	25	2,50
4,5	16	35451516	72	81,4	20	47,6	60,3	20		35,4		25,1	0,84
	24	36451524	108	111,7	20	57,8	80,3	20	51,3	23,2	6,5	35	2,90
5	16	35501516	80	90,5	24	54,1	60,3	20		37,9		25,4	1,10
	24	36501524	120	124,1	24	61,1	80,3	20	54,5	24,9	6,6	35	3,50

MATERIAL C 45 UNI 7847

 CAD drawings available on our site
www.chiaravalli.com

 Quantity, availability and prices
 on B2B Chiaravalli



BEVEL GEAR WITH STRAIGHT TEETH SPECIAL CH EXECUTION GLEASON SYSTEM

BEVEL GEAR WITH STRAIGHT TEETH SPECIAL CH EXECUTION RATIO 1:2.5

RELATION 1:2.5

Normal axis
Pressure angle: 20°

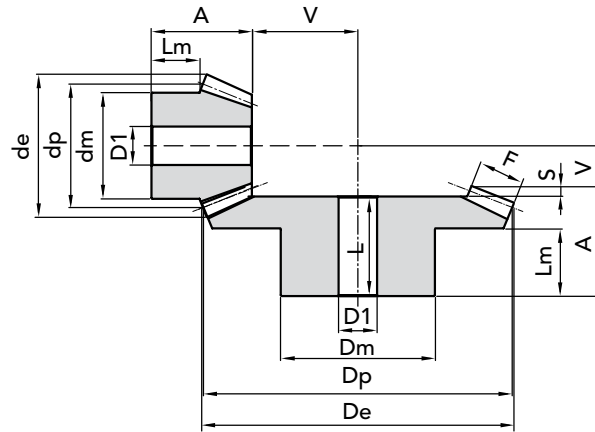
GLEASON SYSTEM



M	Z	PART NUMBER	d_p	d_e	F	A	d_m	D_1	L	V	S	L_m	Kg
1	16	35102516	16	18,6	6,5	14,4	13,3	4		13,6		7,4	0,04
	40	36102540	40	40,4	6,5	14,8	25,3	8	13	5,2	1,8	9	0,09
1.5	16	35152516	24	27,9	11,5	24,2	20,3	8		18,8		12,3	0,04
	40	36152540	60	60,7	11,5	27,8	40,3	14	25,5	7,2	2,3	18	0,17
2	16	35202516	32	37,2	15	29,6	25,3	8		25,4		13,7	0,04
	40	36202540	80	80,9	15	32,4	45,3	16	29	9,6	3,4	20	0,15
2.5	16	35252516	40	46,4	19	38,4	32,3	12		31,6		18,5	0,17
	40	36252540	100	101,1	19	39,8	55,3	16	35,9	12,2	3,9	25	1,23
3	16	35302516	48	55,7	21,5	41,9	40,3	16		39,1		19,6	0,33
	40	36302540	120	121,4	21,5	47,9	60,3	20	44	15,1	3,9	30	1,83
3.5	16	35352516	56	65	22,6	49,1	45,3	20		47,9		25	0,33
	40	36352540	140	141,6	22,6	54,6	80,3	20	50	18,4	4,6	35	1,90
4	16	35402516	64	74,3	26	52,5	55,3	20		54,5		25,3	0,65
	40	36402540	170	161,8	26	57,0	80,3	20	50,5	21	6,5	35	2,53
4.5	16	35452516	72	83,6	30	56,3	60,3	20		60,7		24,6	0,97
	40	36452540	180	182,1	30	59,7	80,3	20	53	23,3	6,7	35	5,30
5	16	35502516	80	92,9	32	65,4	60,3	20		68,6		30,1	1,23
	40	36502540	200	202,3	32	65,7	90,3	20	58,3	26,3	7,4	40	7,20

MATERIAL C 45 UNI 7847

CAD drawings available on our site
www.chiaravalli.com

Quantity, availability and prices
on B2B Chiaravalli





BEVEL GEAR WITH STRAIGHT TEETH SPECIAL CH EXECUTION GLEASON SYSTEM

13

RELATION 1:3

Normal axis
Pressure angle: 20°

GLEASON SYSTEM

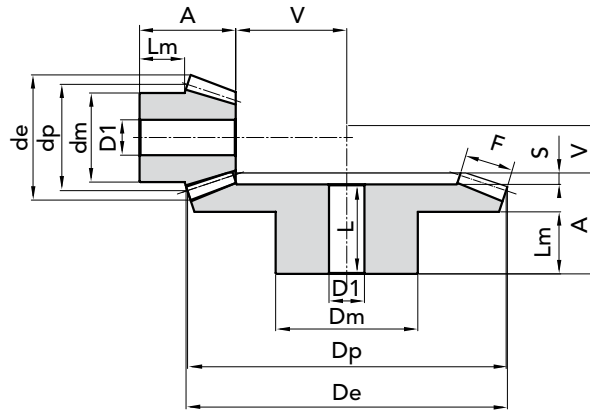

M	Z	PART NUMBER	d_p	d_e	F	A	d_m	D_1	L	V	S	L_m	Kg
1	15	35101315	15	17,7	7,1	16,6	13,3	4		15,4		9,2	0,03
	45	36101345	45	45,3	7,1	17,1	25,3	8	15,2	4,9	1,9	10	0,09
1.5	15	35151315	22,5	26,5	10,5	22,6	19,3	8		23,4		11,7	0,04
	45	36151345	67,5	68,1	10,5	29,6	45,3	14	27,2	7,4	2,4	20	0,40
2	15	35201315	30	35,4	14	28,9	25,3	8		31,1		14,2	0,09
	45	36201345	90	90,8	14	32,1	45,3	16	28,4	9,9	3,7	20	0,62
2.5	15	35251315	37,5	44,2	18	34,6	32,3	12		38,4		15,9	0,17
	45	36251345	112,5	113,4	18	39,7	60,3	20	35,3	12,3	4,4	25	1,19
3	15	35301315	45	53	21	41,3	40,3	16		46,7		19,7	0,29
	45	36301345	135	136,1	21	47,2	60,3	20	42	14,8	5,2	30	1,91
3.5	15	35351315	52,5	61,9	23,5	49,6	45,3	20		55,4		25	0,48
	45	36351345	157,5	158,8	23,5	54,4	80,3	20	48,6	17,6	5,8	35	2,21
4	15	35401315	60	70,7	27,5	54,3	50,3	20		62,7		25,4	0,70
	45	36401345	180	181,5	27,5	57	80,3	20	50,5	20	6,5	35	4,21
4.5	15	35451315	67,5	79,5	28,5	55,2	55,3	20		72,8		24,8	1,14
	45	36451345	202,5	204,2	28,5	63,9	90,3	20	57	23,1	6,9	40	7,03
5	15	35501315	75	88,4	33	65,3	60,3	20		79,7		30	1,45
	45	36501345	225	226,9	33	66,7	90,3	20	59,2	25,3	7,5	40	8,42

BEVEL GEAR WITH STRAIGHT TEETH SPECIAL CH EXECUTION RATIO 1:3

6

MATERIAL C 45 UNI 7847

CAD drawings available on our site
www.chiaravalli.com

Quantity, availability and prices
on B2B Chiaravalli



BEVEL GEAR WITH STRAIGHT TEETH SPECIAL CH EXECUTION GLEASON SYSTEM

BEVEL GEAR WITH STRAIGHT TEETH SPECIAL CH EXECUTION RATIO 1:3.5

RATIO 1:3.5

Normal axis
Pressure angle: 20°

GLEASON SYSTEM

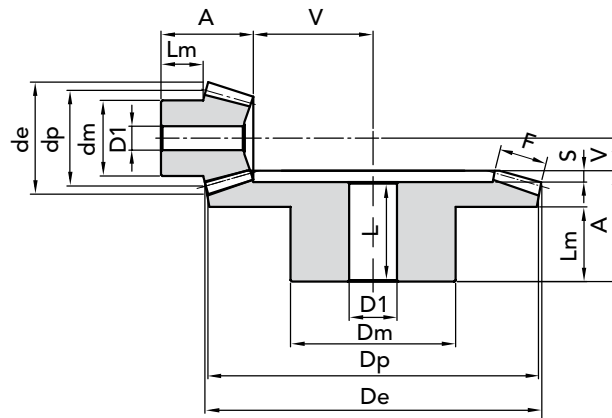

M	Z	PART NUMBER	d_p	d_e	F	A	d_m	D_1	L	V	S	L_m	Kg
1.5	16	35153516	24	28,1	12	24,0	20,3	8		30		11,5	0,05
	56	36153556	84	84,5	12	34,8	45,3	14	32	8,2	2,8	25	0,63
2	16	35203516	32	37,5	16	30,9	25,3	8		40,1		14,1	0,09
	56	36203556	112	112,6	16	37,1	55,3	16	33,3	10,9	3,8	25	1,30
2.5	16	35253516	40	46,8	20	38,9	32,3	14		50,1		17,9	0,20
	56	36253556	140	140,8	20	44,4	60,3	20	40	13,6	4,4	30	2,59
3	16	35303516	48	56,2	24	49,9	40,3	16		60,1		24,9	0,31
	56	36303556	168	169	24	52,7	80,3	20	47,5	16,3	5,2	35	3,94
3.5	16	35353516	56	65,6	25	52,0	45,5	20		73		25,5	0,62
	56	36353556	196	197,1	25	55,1	80,3	20	49,1	19,9	6,0	35	5,60

MATERIAL **C 45 UNI 7847**

CAD drawings available on our site
www.chiaravalli.com

Quantity, availability and prices
on B2B Chiaravalli





BEVEL GEAR WITH STRAIGHT TEETH SPECIAL CH EXECUTION GLEASON SYSTEM

15

RATIO 1:4

Normal axis

Pressure angle: 20°

GLEASON SYSTEM

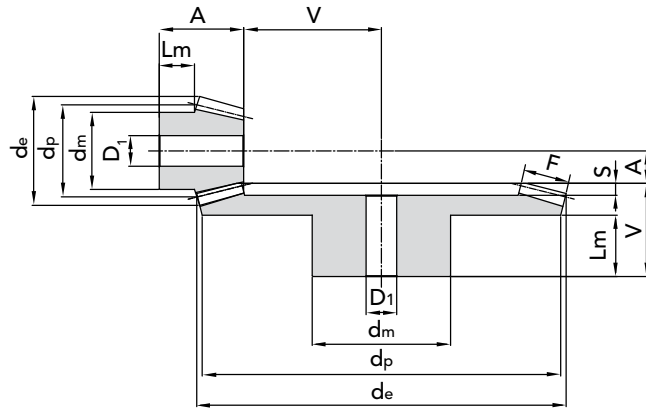

M	Z	PART NUMBER	dp	de	F	A	dm	D1	L	V	S	Lm	Kg
1	15	35101415	15	17,8	9,3	17,2	13,3	4		20,8		7,7	0,03
	60	36101460	60	60,3	9,3	17,1	30,3	8	15,2	4,9	1,9	10	0,15
1,5	15	35151415	22,5	26,7	11	23	20,3	8		34		11,7	0,05
	60	36151460	90	90,4	11	34	50,3	16	31,2	8	2,8	25	0,60
2	15	35201415	30	35,6	16	31	25,3	8		44		14,4	0,09
	60	36201460	120	120,6	16	37,6	60,3	16	34,2	10,4	3,4	25	1,30
2,5	15	35251415	37,5	44,5	19	38,1	32,3	14		55,9		18,4	0,20
	60	36251460	150	150,7	19	44,8	60,3	20	40	13,2	4,8	30	2,59
3	15	35301415	45	53,3	23	48,1	40,3	16		66,9		24,5	0,31
	60	36301460	180	180,8	23	53,2	80,3	20	48,2	15,8	5	35	3,94
3,5	15	35351415	52,5	62,2	26	52,1	45,3	20		78,9		25,1	0,60
	60	36351460	210	211	26	60,4	90,3	20	54,4	18,6	6	40	5,62
4	15	35401415	60	71,1	30	55,1	50,3	20		89,9		23	0,81
	60	36401460	240	241,1	30	60,8	90,3	20	53	21,2	7,8	40	6,43
4,5	15	35451415	67,5	79,97	32	57	52,3	20		102,9		23	1,15
	60	36451460	270	271,24	32	62	90,3	20	53,5	24,3	8,5	40	11,35
5	15	35501415	75	88,8	34	62	55,3	20		115,7		25	1,80
	60	36501460	300	301,3	34	65	90,3	20	55	27	10	40	14,45

BEVEL GEAR WITH STRAIGHT TEETH SPECIAL CH EXECUTION RATIO 1:4

6

MATERIAL **C 45 UNI 7847**



CAD drawings available on our site
www.chiaravalli.com

Quantity, availability and prices
on B2B Chiaravalli



DECLARATION OF INTENT

The **change project** of this range of bevel gears has been developed with the intention of standardising the execution of this product and reducing the number of articles carried in the catalogue.

The **key aspects of the project** to which we intend to draw the attention of users can be specified as follows:

- Deletion of the "special" execution bevel gears and adoption of a single execution with harmonised sizing criteria.
- Adoption of the **DIN 3971** Standards to size the tooth profile and the external body of the gears.
- Systematic correction of teeth by profile displacement to eliminate the undercut effect on the pinions, to improve the slip and the specific pressure and to obtain a tooth that is better able to withstand bending stresses.
- Selection of a standardised external configuration in terms of the front embedding on the bevel gears which will be implemented only from a given module.
- Generalised increase of the surface width to achieve higher load-bearing capacities.
- Selection of the ratios and the number of teeth based solely on the normal number of the R20 range in compliance with the UNI 2016 and the **DIN 323** Standards, as well as the ISO R3 and ISO R17 recommendations, with the following progressions:

Ratio 1:1 = 16 - 18 - 20 - 22 - 25 - 28 - 32

1:2 = 16 / 32

1:3 = 16 / 48

1:4 = 16 / 64

This initiative comes within the framework of a broader critical review of the Company's products, and CHIARAVALLI GROUP SpA intends to implement a form of technical collaboration with customers and will take due consideration of technical advice, suggestions and assessments for which CHIARAVALLI GROUP SpA thanks you in advance.

SPECIAL PRODUCTION CHIARAVALLI GROUP SPA IN COMPLIANCE WITH NORM DIN 3971

ITEMS AVAILABLE
TILL SOLD OUT



LOAD CAPACITY OF BEVEL GEARS FOR TRANSMISSIONS BETWEEN ORTHOGONAL AXES

The mechanical performance or rather the load capacity of bevel gears is defined by the twisting moments that the gears are capable to transmit:

- in the form of dynamic torque, when in motion;
- in the form of static torque, when stationary or moving slowly.

The dynamic torque (M_d) represents the limit yielding torque due to bending fatigue, whereas the static torque (M_s) indicates the limit torque at failure by yielding due to tooth bending.

The values declared for both torques are the maximum permitted values and have been tested in compliance with the calculation codes and based on the limiting stress values detailed in the DIN 3991 STANDARDS method C.

The calculations test are valid for a Service Factor (SF) equal to 1 in the absence of data regarding the real operating conditions.

We recommend adopting a safety factor equal to at least 1.5 to adjust the nominal torque to the operating torque.

IN COMPLIANCE WITH DIN 3971

LOAD CAPACITY OF BEVEL GEARS FOR TRANSMISSIONS BETWEEN ORTHOGONAL AXES

Rapp.	M	Z	$M_d (N_m)$	$M_s (N_m)$	M	Z	$M_d (N_m)$	$M_s (N_m)$	
1:1	1	16	1,35	3,6	3	16	36,8	96	
		18	1,61	4,25		18	48	107	
		20	2	5,35		20	60	158	
		22	2,5	6,55		22	68	182	
		25	3,2	8,35		25	90	235	
		28	4	10,4		28	105	276	
	1,5	32	5,25	13,8	32	135	354		
		16	4,4	11,5	3,5	16	58	152	
		18	5,5	14,35		18	71	171	
		20	6,7	17,6		20	90	246	
		22	8	21,1		22	111	300	
		25	10,5	27,6		25	140	361	
28	13,2	35	28	175		449			
2	2	32	17,2	40,1	4	32	218	584	
		16	10	26,3		4	16	83,6	219
		18	12,5	30			18	111	290
		20	15	39,5			20	138	360
		22	18,6	48,8			22	167	437
		25	25,4	65,5			25	212	554
	28	31,5	82,5	28	260		681		
	2,5	32	40	95,15	5	32	327	855	
		16	18,5	48,5		5	16	159	415
		18	24	62			18	201	525
		20	29,5	68,8			20	248	645
		22	36	94			22	300	782
25		45	118	25			394	1029	
28	58,5	132	28	480	1253				
	32	76,5	200		32	595	1557		

Rapp.	M	Dynamic torque M_d	Static torque M_s
1:2	1	6,5 Nm	17,2 Nm
	1,5	23,5 Nm	61,5 Nm
	2	52,3 Nm	137 Nm
	2,5	102 Nm	267 Nm
	3	176 Nm	460 Nm
	3,5	287 Nm	745 Nm
1:3	4	416 Nm	1086 Nm
	5	808 Nm	2114 Nm
	1	18,5 Nm	48,5 Nm
	1,5	55 Nm	145 Nm
	2	136 Nm	355 Nm
	2,5	270 Nm	704 Nm
1:4	3	470 Nm	1228 Nm
	3,5	731 Nm	1910 Nm
	4	1074 Nm	2807 Nm
	5	2085 Nm	3508 Nm
	1	40,5 Nm	106 Nm
	1,5	117 Nm	306 Nm
1:4	2	277 Nm	724 Nm
	2,5	540 Nm	1410 Nm
	3	956 Nm	2500 Nm
	3,5	1471 Nm	3845 Nm
	4	2087 Nm	5454 Nm
	5	3926 Nm	10270 Nm

LOAD CAPACITY OF BEVEL GEARS FOR TRANSMISSIONS BETWEEN ORTHOGONAL AXES



LOAD CAPACITY OF BEVEL GEARS FOR TRANSMISSIONS BETWEEN ORTHOGONAL AXES

ØD axe = is the minimum diameter of the axe able to transmit the dynamic twisting couple with a cut sollicitation equal to 60 N/mm².

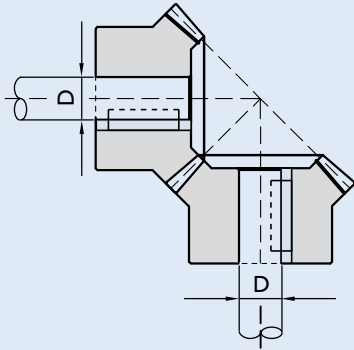

IN COMPLIANCE WITH DIN 3971

ØD1 = Axe's minimum diameter on the entrance chain sprocket
ØD2 = Axe's minimum diameter on the wheel.

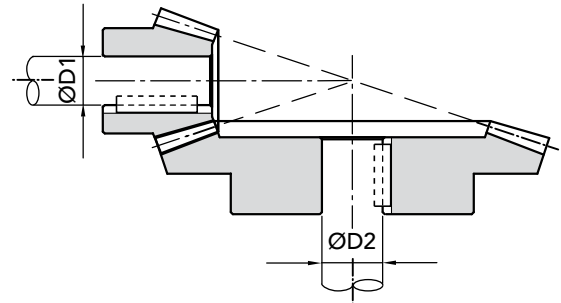

PAY ATTENTION The axe's diameters result commensurated to the dynamic couple in exit and they are resistance verified for a cut sollicitation equal to 60 N/mm².

Rapp.	M	Z	ØD shaft	M _s (N _m)	M	Z	ØD shaft	M _d (N _m)	
1:1	1	16	4	3,6	3	16	13	96	
		18	5	4,25		18	15	107	
		20	5	5,35		20	16	158	
		22	5	6,55		22	16	182	
		25	6	8,35		25	18	235	
		28	6	10,4		28	19	276	
	1,5	1,5	32	7	13,8	3,5	32	20	354
			16	7	11,5		16	15	152
			18	7	14,35		18	17	171
			20	8	17,6		20	18	246
			22	8	21,1		22	19	300
			25	9	27,6		25	21	361
	2	2	28	9	35	4	28	22	449
			32	10	40,1		32	24	584
			16	9	26,3		16	17	219
			18	9	30		18	19	290
			20	10	39,5		20	21	360
			22	11	48,8		22	22	437
	2,5	2,5	25	12	65,5	5	25	24	554
			28	13	82,5		28	25	681
			32	14	95,15		32	28	855
			16	11	48,5		16	22	415
			18	12	62		18	23	525
			20	12	68,8		20	25	645
3	3	22	13	94	5	22	27	782	
		25	14	118		25	29	1029	
		28	16	132		28	31	1253	
		32	17	200		32	34	1557	

Rapp.	M	Dynamic torque M _d	Static torque M _s	ØD1
1:2	1	6,5 Nm	17,2 Nm	6 7
	1,5	23,5 Nm	61,5 Nm	9 11
	2	52,3 Nm	137 Nm	12 15
	2,5	102 Nm	267 Nm	15 19
	3	176 Nm	460 Nm	18 22
1:3	3,5	287 Nm	745 Nm	21 26
	4	416 Nm	1086 Nm	24 30
	5	808 Nm	2114 Nm	30 37
	1	18,5 Nm	48,5 Nm	7 11
	1,5	55 Nm	145 Nm	11 15
1:4	2	136 Nm	355 Nm	14 21
	2,5	270 Nm	704 Nm	18 26
	3	470 Nm	1228 Nm	22 31
	3,5	731 Nm	1910 Nm	25 36
	4	1074 Nm	2807 Nm	28 41
1:5	5	2085 Nm	3508 Nm	35 51
	1	40,5 Nm	106 Nm	9 14
	1,5	117 Nm	306 Nm	12 20
	2	277 Nm	724 Nm	16 26
	2,5	540 Nm	1410 Nm	20 33
1:6	3	956 Nm	2500 Nm	25 39
	3,5	1471 Nm	3845 Nm	29 45
	4	2087 Nm	5454 Nm	32 51
	5	3926 Nm	10270 Nm	40 63



BEVEL GEARS FOR TRANSMISSIONS BETWEEN ORTHOGONAL AXES IN COMPLIANCE WITH DIN 3971

GEAR RATIO 1:1

Straight teeth Bevel Gears sized in compliance with DIN 3971

Corrected toothing by profile displacement and length-wise crowning of the tooth.

Pressure angle: 20°

Teeth according to DIN 3971

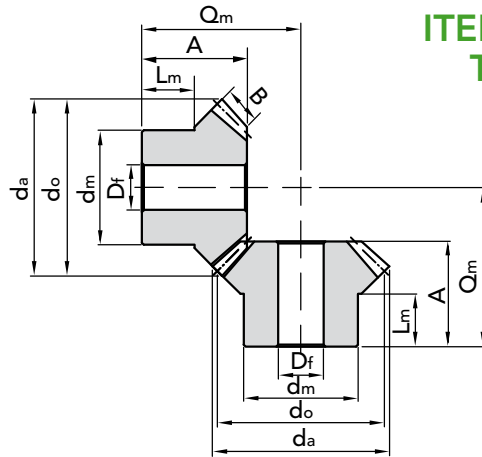

ITEMS AVAILABLE TILL SOLD OUT

M	Z	PART NUMBER	d _o	d _a	D _m	D _f	B	L _m	A	Q _m	Tolerance		Kg.
											min.	max	
1	16	37101116	16	17	12	4	4	7	12,28	17	-0,02	0,02	
	18	37101118	18	19	14	4	4	7	12,31	18	-0,02	0,02	
	20	37101120	20	21	16	4	4,5	8	13,66	20	-0,02	0,02	
	22	37101122	22	23	18	5	5	8	14,01	21	-0,02	0,02	
	25	37101125	25	26	20	5	5,5	8	14,87	23	-0,02	0,02	
	28	37101128	28	29	20	5	6	9	17,74	27	-0,02	0,02	
	32	37101132	32	33	22	5	7	12	20,44	31	-0,02	0,02	
1,5	16	37151116	24	25,5	18	6	5,5	10	17,6	25	-0,02	0,02	
	18	37151118	27	28,5	20	8	6	12	20,47	29	-0,02	0,02	
	20	37151120	30	31,5	22	8	6,5	12	21,33	31	-0,02	0,02	
	22	37151122	33	34,5	24	8	7	12	22,19	33	-0,02	0,02	
	25	37151125	37,5	39	28	8	8	13,5	24,64	37	-0,03	0,03	
	28	37151128	42	43,5	30	12	9	14	27,1	41	-0,03	0,03	
	32	37151132	48	49,5	36	12	10	16	29,82	46	-0,03	0,03	
2	16	37201116	32	34	24	8	7	14	23,92	34	-0,02	0,02	
	18	37201118	36	38	28	8	7,5	15	25,3	37	-0,03	0,03	
	20	37201120	40	42	28	8	8	15	24,67	38	-0,03	0,03	
	22	37201122	44	46	30	12	9	16	28,37	43	-0,03	0,03	
	25	37201125	50	52	32	12	11	16	29,75	46	-0,03	0,03	
	28	37201128	56	58	36	12	12	18	34,47	53	-0,03	0,03	
	32	37201132	64	66	40	14	13	20	38,2	60	-0,03	0,03	
2,5	16	37251116	40	43	30	12	8	14	25,92	39	-0,03	0,03	
	18	37251118	45	48	34	12	9	15	28,13	43	-0,03	0,03	
	20	37251120	50	53	35	12	10	18	32,34	49	-0,03	0,03	
	22	37251122	55	58	42	14	11	18	33,55	52	-0,03	0,03	
	25	37251125	62,5	65,5	46	14	12	20	34,5	56	-0,03	0,03	
	28	37251128	70	73	48	14	14	22	40,17	64	-0,03	0,03	
	32	37251132	80	83	52	16	16	22	43,58	71	-0,03	0,03	

MATERIAL C 45 UNI 7847

CAD drawings available on our site
www.chiaravalli.com

Quantity, availability and prices
 on B2B Chiaravalli



BEVEL GEARS FOR TRANSMISSIONS BETWEEN ORTHOGONAL AXES GEAR RATIO 1:1



GEAR RATIO 1:1

Straight teeth Bevel Gears sized in compliance with DIN 3971

Corrected toothing by profile displacement and length-wise crowning of the tooth.

Pressure angle: 20°

Teeth according to DIN 3971

ITEMS AVAILABLE
TILL SOLD OUT

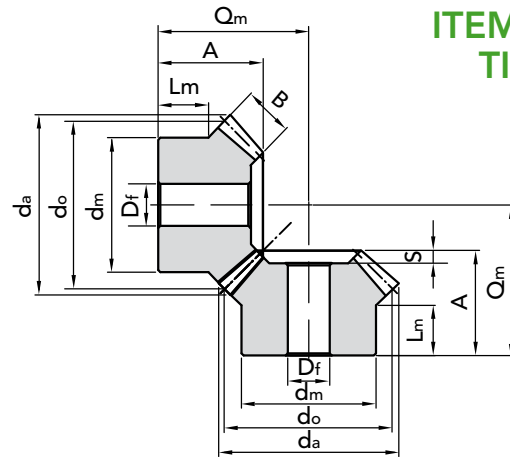

M	Z	PART NUMBER	d_o	d_a	D_m	D_f	B	L_m	A	S	Q_m	Tolerance min.	Q_m max	Kg.
3	16	37301116	48	51,5	36	12	12	16	31,85	4	46	-0,03	0,03	
	18	37301118	54	57,5	40	14	14	18	36,24	4	52	-0,03	0,03	
	20	37301120	60	63,5	45	14	16	20	37,63	4	55	-0,03	0,03	
	22	37301122	66	69,5	50	16	16	20	37,7	4	58	-0,03	0,03	
	25	37301125	75	78,5	50	16	16	24	45,29	4	70	-0,03	0,03	
	28	37301128	84	87,5	55	16	18	25	48,21	4	76	-0,03	0,03	
	32	37301132	96	99,5	66	16	20	25	49,63	4	82	-0,04	0,04	
3,5	16	37351116	56	60	40	14	14	18	35,5	5	52	-0,03	0,03	
	18	37351118	63	67	45	14	16	18	38,4	5	57	-0,03	0,03	
	20	37351120	70	74	50	16	18	22	44,3	5	65	-0,03	0,03	
	22	37351122	77	81	55	16	20	22	46,21	5	69	-0,03	0,03	
	25	37351125	87,5	91,5	60	16	20	25	48,07	5	76	-0,04	0,04	
	28	37351128	98	102	65	16	22	25	50,25	5	82	-0,04	0,04	
	32	37351132	112	116	75	20	25	25	55,37	5	92	-0,04	0,04	
4	16	37401116	64	69	48	16	15	25	45,5	6	65	-0,03	0,03	
	18	37401118	72	77	55	16	18	25,5	49,55	6	71	-0,03	0,03	
	20	37401120	80	85	60	16	20	27	49,97	6	74	-0,03	0,03	
	22	37401122	88	93	62	16	22	27	55,38	6	82	-0,04	0,04	
	25	37401125	100	105	70	20	24	25	54,84	6	86	-0,04	0,04	
	28	37401128	112	117	80	20	26	25	55,28	6	91	-0,04	0,04	
	32	37401132	128	133	90	20	28	30	59,75	6	102	-0,04	0,04	
5	16	37501116	80	86	60	16	18	25	50,14	7	75	-0,03	0,03	
	18	37501118	90	96	63	16	20	30	54,56	7	83	-0,04	0,04	
	20	37501120	100	106	70	20	22	30	59,99	7	92	-0,04	0,04	
	22	37501122	110	116	80	20	24	30	60,41	7	96	-0,04	0,04	
	25	37501125	125	131	85	20	28	35	69,71	7	110	-0,04	0,04	
	28	37501128	140	146	90	20	30	38	74,67	7	121	-0,04	0,04	
	32	37501132	160	166	100	20	32	45	85,16	7	140	-0,04	0,04	

MATERIAL C 45 UNI 7847

CAD drawings available on our site
www.chiaravalli.com

Quantity, availability and prices
on B2B Chiaravalli





BEVEL GEARS FOR TRANSMISSIONS BETWEEN ORTHOGONAL AXES IN COMPLIANCE WITH DIN 3971

GEAR RATIO 1:2

Straight teeth Bevel Gears sized in compliance with DIN 3971

Corrected toothing by profile displacement and length-wise crowning of the tooth.

Pressure angle: 20°

Teeth according to DIN 3971

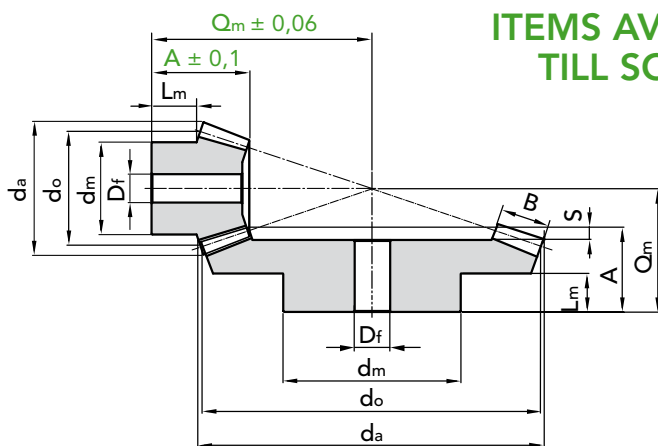

ITEMS AVAILABLE TILL SOLD OUT

M	Z	PART NUMBER	d _o	d _a	D _m	D _f	B	L _m	A	S	Q _m	Tolerance Q _m		Kg.
												min.	max	
1	16	37101216	16	18	12	4	6	5	11,78		22	-0,02	0,02	
	32	38101232	32	32	18	5	6	10	18,04	2	23	-0,02	0,02	
1,5	16	37151216	24	27	18	8	10	10,5	21,53		36	-0,03	0,03	
	32	38151232	48	48	30	8	10	14	24,97	3	32	-0,03	0,03	
2	16	37201216	32	36	24	8	12	11	24,56		45	-0,03	0,03	
	32	38201232	64	64,5	36	12	12	13	28,08	4	38	-0,03	0,03	
2,5	16	37251216	40	45,5	32	12	15	15	32,45		58	-0,03	0,03	
	32	38251232	80	80,5	48	16	15	18	37,6	5	50	-0,03	0,03	
3	16	37301216	48	55	36	14	18	14	34,34	3	65	-0,04	0,04	
	32	38301232	96	97	60	14	18	20	40,12	5	55	-0,04	0,04	
3,5	16	37351216	56	64	42	14	22	18	42,1	3	77	-0,04	0,04	
	32	38351232	112	113	70	16	22	22	45,06	6	62	-0,04	0,04	
4	16	37401216	64	73	48	14	24	20	45,13	4	86	-0,04	0,04	
	32	38401232	128	129	80	20	24	25	50,16	7	70	-0,04	0,04	
5	16	37501216	80	91	56	16	30	25	59,91	5	111	-0,04	0,04	
	32	38501232	160	161	100	20	30	30	60,2	8	85	-0,04	0,04	

MATERIAL **C 45 UNI 7847**

CAD drawings available on our site
www.chiaravalli.com

Quantity, availability and prices
on B2B Chiaravalli



BEVEL GEARS FOR TRANSMISSIONS BETWEEN ORTHOGONAL AXES GEAR RATIO 1:2



BEVEL GEARS FOR TRANSMISSIONS BETWEEN ORTHOGONAL AXES IN COMPLIANCE WITH DIN 3971

GEAR RATIO 1:4

Straight teeth Bevel Gears sized in compliance with DIN 3971

Corrected toothing by profile displacement and length-wise crowning of the tooth.

Pressure angle: 20°

Teeth according to DIN 3971

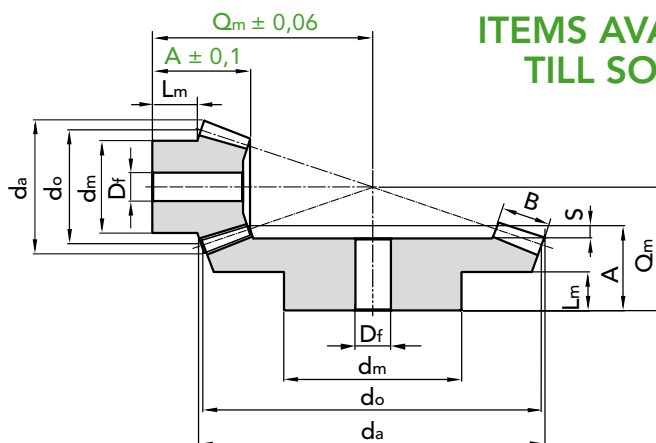

ITEMS AVAILABLE TILL SOLD OUT

M	Z	PART NUMBER	d _o	d _a	D _m	D _f	B	L _m	A	S	Q _m	Tolerance Q _m min.	Q _m max	Kg.
1	16	37101416	16	18	14	4	10	7,75	17,94		40	-0,04	0,04	
	64	38101464	64	63,5	38	8	10	12	21,69	2,5	27	-0,04	0,04	
1,5	16	37151416	24	27,5	20	8	12	12,45	25,08		61	-0,05	0,05	
	64	38151464	96	95,5	56	16	12	15	30,35	3	39	-0,05	0,05	
2	16	37201416	32	37	26	10	16	11,2	28,11		76	-0,05	0,05	
	64	38201464	128	127,5	75	16	16	16	32,47	4	44	-0,05	0,05	
2,5	16	37251416	40	46,5	32	14	20	14	35,13		95	-0,06	0,06	
	64	38251464	160	159,5	90	20	20	20	40,58	5	55	-0,06	0,06	
3	16	37301416	48	56	40	14	25	13	39,12	2	110	-0,06	0,06	
	64	38301464	192	191,5	100	20	25	20	44,93	6	62	-0,06	0,06	
3,5	16	37351416	56	66	48	16	28	15	44,19	3	128	-0,07	0,07	
	64	38351464	224	223,5	120	20	28	30	59,82	7	80	-0,07	0,07	
4	16	37401416	64	75	52	16	32	20,5	54,22	3	150	-0,07	0,07	
	64	38401464	256	255,5	140	20	32	35	70,93	8	94	-0,07	0,07	
5	16	37501416	80	94,5	65	16	36	22,1	60,44	4	184	-0,08	0,08	
	64	38501464	320	320	170	20	36	35	75,24	10	105	-0,08	0,08	

MATERIAL C 45 UNI 7847

CAD drawings available on our site
www.chiaravalli.com

Quantity, availability and prices
on B2B Chiaravalli



BEVEL GEARS FOR TRANSMISSIONS BETWEEN ORTHOGONAL AXES GEAR RATIO 1:4



The "GLEASON" system range of bevel gears with spiral tothing is an extension of the range of standard bevel gear pairs with which this range shares the declared intentions and objectives.

The criteria adopted comply as closely as possible with International Standards as regards general sizing and the definition of the geometric features, whereas the choice of the key nominal data has been based on a progression depending on the range of the normal numbers established by the **DIN 323** and **ISO R3/R17** standards.

The spiral tothing complying with the "GLEASON" system is the result of a specific project designed to achieve optimised functional features compared with the geometric parameters that frequently conflict with each other.

The key sizing for the tothing, in particular refers to the following:

- The choice of a reduced tooth height - Correction by profile displacement

- Adoption of a normal pressure angle:

$\alpha_n = 20^\circ$ - The constant tooth bottom gap along the whole tooth surface and other geometric solutions. This series of bevel gear with spiral tothing is designed for general use in plants and in general mechanical applications. The project has been designed therefore, to privilege the mechanical performance normally requested by this sector and special attention has been paid in defining the geometric features that can determine the tooth covering factor and the restraining reactions which determine the load on the bevel gear pair bearings.

By their very nature bevel gears with spiral tothing are designed for a more demanding use compared with that of straight teeth bevel gear pairs therefore, CHIARAVALLI GROUP SpA has made available the Company's range of bevel gear pairs with the intention of providing a solution that will be appreciated by the users of this product.

Naturally and in the framework of the Company's traditional technical collaboration with end users, the CHIARAVALLI GROUP SpA technical office is available to provide suggestions concerning more specific circumstances and problems.

GLEASON SYSTEM



Directions and angles of forces acting on spiral bevel gears

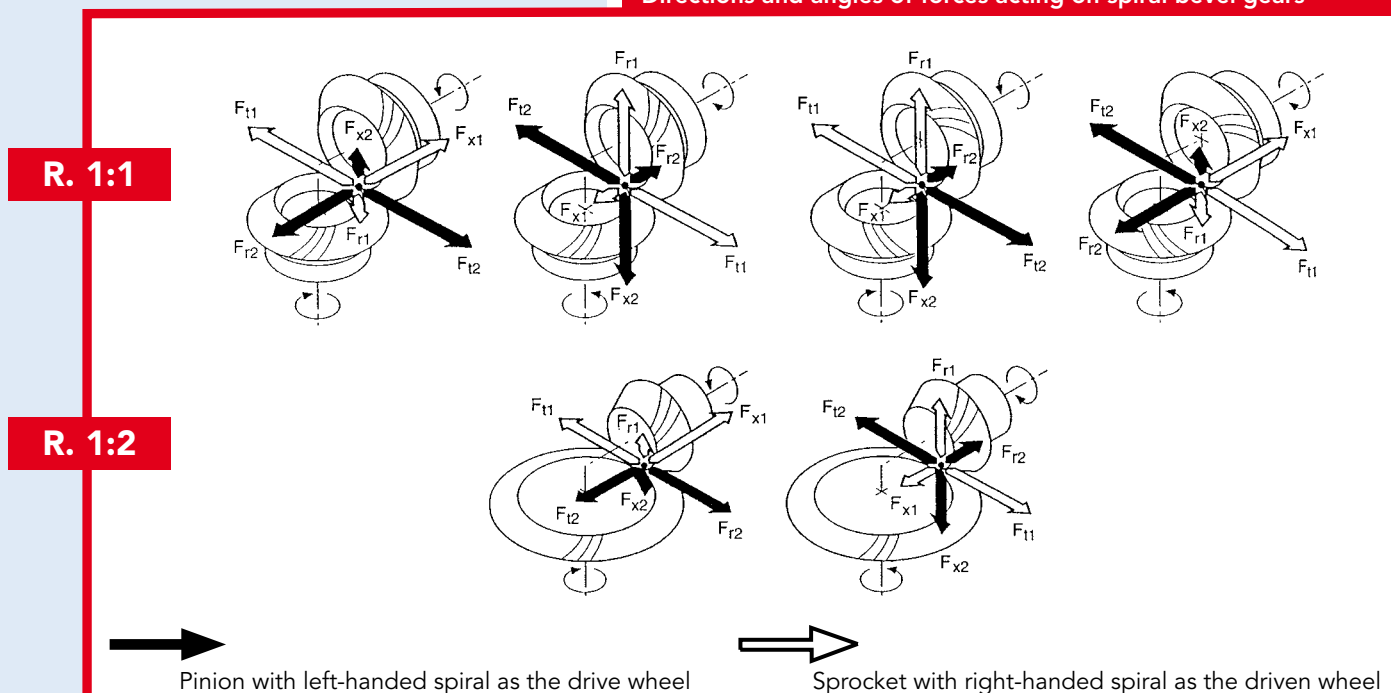



RATIO 1:1

GLEASON SYSTEM

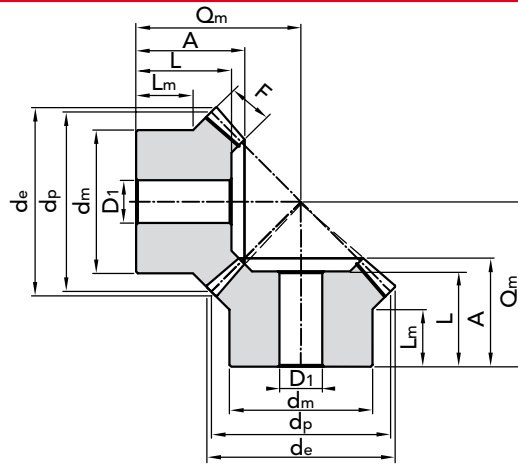

M	Z	PART NUMBER SX	PART NUMBER DX	d _p	d _m	D ₁	F	d _e	L _m	L	A	Q _m	Kg
1,5	16	31151116	31151117	24	18	8	6	25,3	9	16	16,7	24	0,04
	20	31151120	31151121	30	22	8	7	31,3	10	18	19,4	29	-0,05
	25	31151125	31151126	37,5	28	8	8	38,8	11,5	21	22,5	35	-0,1
	30	31151130	31151131	45	32	10	10	46,3	11	23	25,1	40	0,40
2	16	31201116	31201117	32	25	10	9	34	9,45	16,9	19,9	29	0,06
	20	31201120	31201121	40	32	10	12	42	11,95	21,7	24,9	36	-0,05
	25	31201125	31201126	50	40	12	14	52	11,9	24,8	27,4	42	-0,1
	30	31201130	31201131	60	50	12	16	62	12,95	26,9	29,9	48	0,42
2,5	16	31251116	31251117	40	32	12	10	42,5	13	21,8	24,8	37	0,13
	20	31251120	31251121	50	40	12	12	52,5	16	26,7	30,2	46	-0,05
	25	31251125	31251126	62,5	50	15	15	65	16	29,9	33,2	53	-0,1
	30	31251130	31251131	75	55	15	18	77,5	16	31,8	35	59	0,69
3	16	31301116	31301117	48	40	15	12	51	16	25,8	29,4	44	0,23
	20	31301120	31301121	60	45	15	18	63	13,5	30,7	34,5	51	-0,076
	25	31301125	31301126	75	55	15	20	78	16	33,7	37,5	60	-0,127
	30	31301130	31301131	90	60	20	22	93	19	35,8	39,5	68	0,99
4	16	31401116	31401117	64	50	15	15	68	17,75	30,8	36	56	0,51
	20	31401120	31401121	80	60	18	17	84	18	32,5	37,5	64	-0,102
	25	31401125	31401126	100	70	20	21	104	18	35,2	40,4	74	-0,152
	30	31401130	31401131	120	80	25	25	124	16	38,1	43,2	84	2,10
5	16	31501116	31501117	80	60	20	17	85	18,9	35,5	41,9	68	0,88
	20	31501120	31501121	100	70	20	21	105	18,5	37,7	44,8	78	-0,127
	25	31501125	31501126	125	90	20	26	130	18,5	41,8	47,8	90	-0,178
	30	31501130	31501131	150	110	30	32	155	18	45,7	52,5	103	4,25

SPIRAL BEVEL GEARS RATIO 1:1

MATERIAL C 45 UNI 7847



CAD drawings available on our site
www.chiaravalli.com

**Quantity, availability and prices
on B2B Chiaravalli**



RATIO 1:2

GLEASON SYSTEM

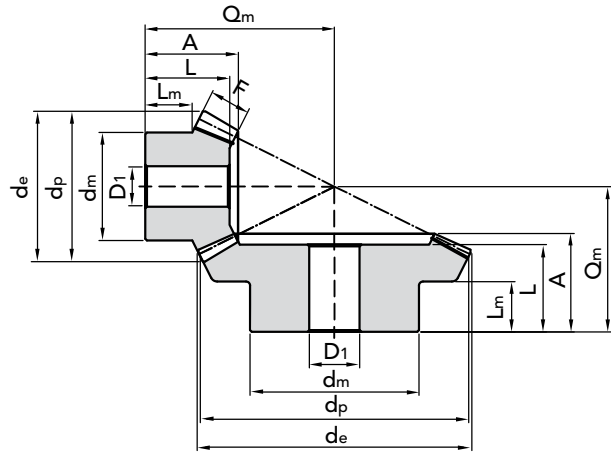

M	Z	PART NUMBER SX	PART NUMBER DX	d_p	d_m	D_1	F	d_e	L_m	L	A	Q_m	Kg	
1,5	16	31151216		24	20	10	8	26,5	9,5	17	18,6	35	-0,05 -0,1	0,07
	32		31151232	48	32	12	8	48,3	10	18	20	28	-0,05 -0,1	0,29
2	16	31201216		32	27	10	10	35,5	11,7	21	22,5	45	-0,05 -0,1	0,09
	32		31201232	64	40	12	10	64,5	10	21,5	24,1	35	-0,05 -0,1	0,32
2,5	16	31251216		40	32	12	12	44,5	14	25,1	27,5	56	-0,05 -0,1	0,17
	32		31251232	80	50	15	12	80,5	15	25,9	29,2	43	-0,05 -0,1	0,57
3	16	31301216		48	40	15	15	53,5	12	25,2	28,4	62	-0,076 -0,127	0,25
	32		31301232	96	60	15	15	97	15	29,8	34,6	51	-0,076 -0,127	1,03
4	16	31401216		64	50	20	20	71,5	13,5	32,2	36,2	81	-0,102 -0,152	0,52
	32		31401232	128	80	20	20	129	23	38,7	44,2	66	-0,102 -0,152	2,21
5	16	31501216		80	60	20	25	89,5	21	45,3	50	106	-0,127 -0,178	1,16
	32		31501232	160	90	25	25	162	27	46,8	53,7	81	-0,127 -0,178	2,79

MATERIAL C 43 UNI 7847

CAD drawings available on our site
www.chiaravalli.com

Quantity, availability and prices
 on B2B Chiaravalli







SPECIAL PRODUCTIONS ON REQUEST





Bevel tothing
straight teeth or spiral
helical GLEASON SYSTEM
case-hardened or ductile
with minimum dimensions from...
to maximum...
in quality **Class 7**
according to **DIN 3962**

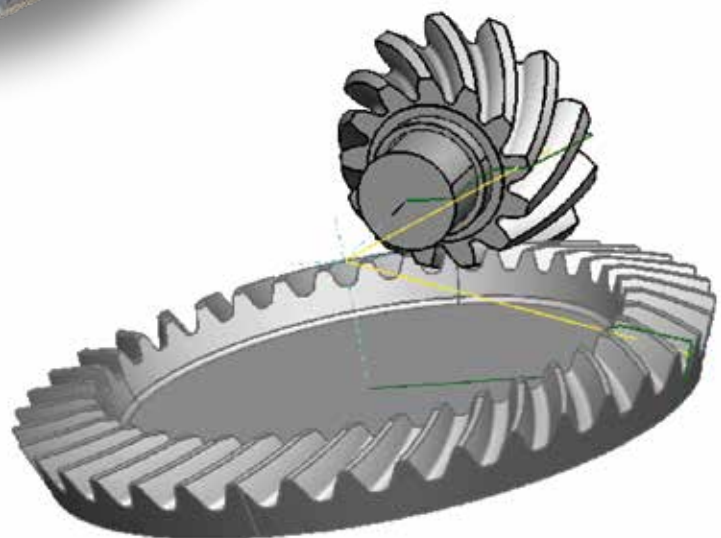
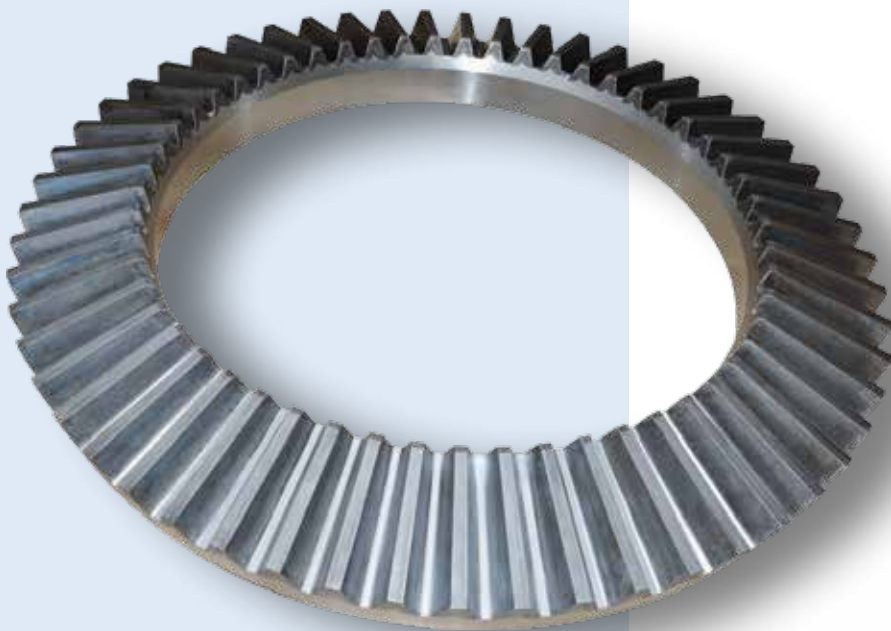



OUR MACHINE TOOLS FLEET

OUR MACHINE TOOLS FLEET



A very modern machine tools fleet, constantly updated with annual fixed important investments.

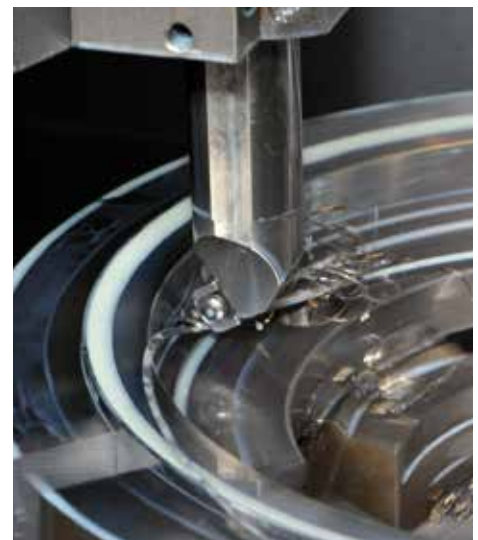



A wide range of three-dimensional measuring machines to assure a certified quality.



WORM SCREW

JACKS

The new line of Worm Screw Jacks named CHT (Chiaravalli High Tech) integrates and completes our range of Mechanical Transmission products.

This new line of products is manufactured using high quality materials, manufactured with absolute precision, making use of the modern machinery fleet of the companies belonging to Chiaravalli Group SpA.

The basic elements that make up the final product "Screw Jack" are made in large series, rigorously checked and put in stock.

Special virtual software developed by Chiaravalli Group SpA enables our customers to first view the various elements of the required screw jack and then, in the second phase, to order it with absolute precision and confidence.

Chiaravalli Group SpA is engaged to ensure the delivery of this product in very short time, with quality and precision.

